



FINERPOWER
TRANSMISSIONS

Koyo Premium Bearings



Koyo

Koyo

KOYO BEARINGS

Deep Groove Ball Bearings6.1.4

6000 Series.....	6.1.4
6200 Series.....	6.1.6
6300 Series.....	6.1.8
6400 Series.....	6.1.10
60/62/63 Series.....	6.1.10
Miniature Series.....	6.1.14
6800 Series.....	6.1.16
6900 Series.....	6.1.18
16000 Series.....	6.1.20

Open Ball Bearings6.1.28

6000, 6200 & 6300 Series.....	6.1.22
-------------------------------	--------

Tapered Roller Bearings6.1.28

30200 Series.....	6.1.28
30300 Series.....	6.1.30
32000 Series.....	6.1.34
32200 Series.....	6.1.36
32300 Series.....	6.1.38
32900 Series.....	6.1.40
33000 Series.....	6.1.42
33100 Series.....	6.1.44
33200 Series.....	6.1.46
Imperial Series.....	6.1.48

Trailer Bearing Kits6.1.53

KOYO Premium Trailer Bearing Kits.....	6.1.53
--	--------

Spherical Roller Bearings6.1.54

22200 Series.....	6.1.54
-------------------	--------

Cylindrical Roller Bearings6.1.56

N/NF Series.....	6.1.56
NU/NJ/NUP Series.....	6.1.60

Cylindrical Roller Thrust Bearings.....6.1.70

K Metric Series/GS Outer Washer/WS Inner Washer.....	6.1.70
--	--------

Thrust Ball Bearings.....6.1.72

51100 - 51300 Series.....	6.1.72
---------------------------	--------

Angular Contact Ball Bearings6.1.76

5300 Series.....	6.1.76
7000 - 7300 Series.....	6.1.78
Agricultural Planter Bearings.....	6.1.80

Self Aligning Ball Bearings6.1.82

2RS Series.....	6.1.86
-----------------	--------

Needle Roller Shell Type (Drawn Cup) - Metric6.1.88

HK Series.....	6.1.88
BK (Closed One End) Series.....	6.1.94

Needle Roller Shell Type (Drawn Cup) - Imperial6.1.96

WJ (Sigma Cage) Series.....	6.1.96
-----------------------------	--------

Needle Roller Bearings Shell Type (Full Complement)6.1.98

B Imperial Series.....	6.1.98
BH Heavy Series.....	6.1.116

Needle Roller Thrust Bearings.....6.1.122

AXK Metric Series.....	6.1.122
AS Metric Washer Series.....	6.1.123
NTA Series.....	6.1.124
TRA/TRB/TRC/TRD Series.....	6.1.125

Combined Needle Roller & Thrust Bearings6.1.132

NAXK - NAXK-Z Series.....	6.1.132
NAXR-Z (Metric with Dust Cap) Series.....	6.1.134

Machined Type without Inner Ring...6.1.136

NK Series - Metric.....	6.1.136
-------------------------	---------

Inner Ring to suit Machined Type Needle Roller6.1.138

JR Series - Metric.....	6.1.138
-------------------------	---------

Machined Type Heavy Duty without Inner Ring6.1.139

NKS (Metric without Inner Ring) Series.....	6.1.139
---	---------

Machined Type Needle Roller6.1.140

NKJ Series.....	6.1.140
NKJS Series.....	6.1.144
NA Series.....	6.1.144

Roller Clutch.....6.1.146

Drawn Cup Roller Clutch FCB Series.....	6.1.146
Drawn Cup Roller Clutch RCB Series.....	6.1.147

Cam Followers.....6.1.147

NUKR Series - Metric.....	6.1.147
Cylindrical Outer - Imperial.....	6.1.148

Roller Followers6.1.152

STO Series - Metric.....	6.1.152
NA-2RS Series.....	6.1.154
NUTR Series - Metric.....	6.1.156
NATR Series - Metric.....	6.1.156
YCRS Series.....	6.1.158

Automotive Bearings6.1.162

Automotive Angular Contact Bearings.....	6.1.162
Automotive Taper Roller Bearings.....	6.1.163
Automotive Ball Bearings.....	6.1.164
Automotive Clutch Release Bearings.....	6.1.165
Automotive Cylindrical Roller Bearings - Gearbox.....	6.1.165
Automotive Needle Roller Bearings.....	6.1.166
Automotive Tensioner Pulleys.....	6.1.167
Automotive Hub Units.....	6.1.168

Interchange Chart6.1.169

Tapered Roller Bearings.....	6.1.169
Needle Roller Bearings.....	6.1.170

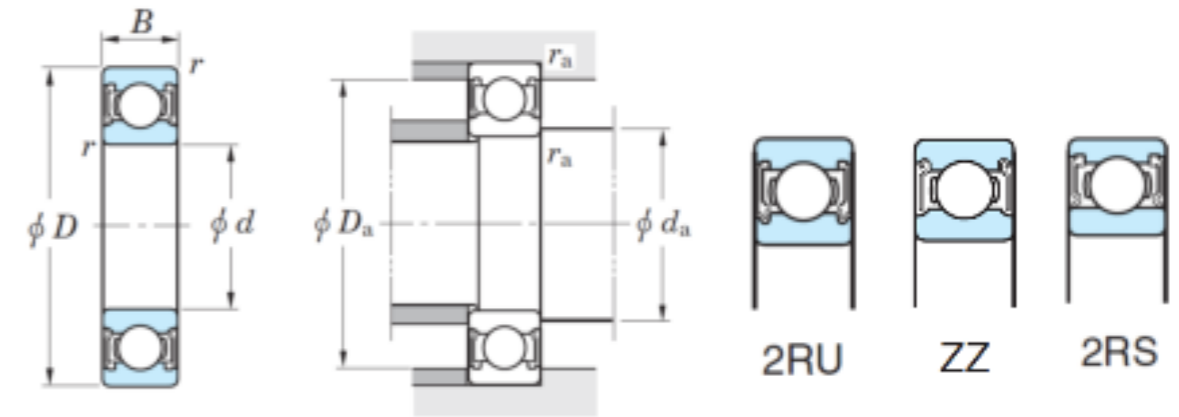
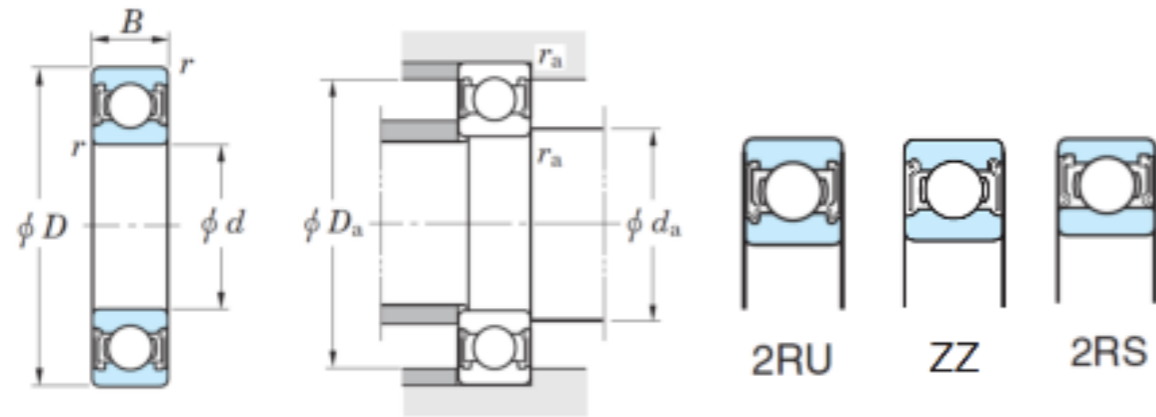

Boundary dimensions(mm)				Basic load ratings(kN)		Fatigue load limit(kN)	Factor	Limiting speeds(min-1)				Bearing No.					Mounting dimensions			Mass Open type (kg)	
d	D	B	r min.	Cr	Cor	Cu	fo	Grease lub.			Bearing Ref	Open	Shielded	Non-contact sealed*	Extremely light contact sealed*	Contact sealed	da		Da		ra
								(Z, ZZ RU, 2RU)	(RD, 2RD)	(RS, 2RS)							min.	max.	max		max
10	26	8	0.3	5.7	1.95	0.1	12.3	31 000	28 000	19 000	6000	-	6000 ZZ	6000 2RU	6000 2RD	6000 2RS	12	13	24	0.3	0.019
12	28	8	0.3	6.4	2.4	0.12	13.2	27 000	24 000	17 000	6001	-	6001 ZZ	6001 2RU	6001 2RD	6001 2RS	14	15	26	0.3	0.022
15	32	9	0.3	7	2.85	0.15	13.9	23 000	21 000	14 000	6002	-	6002 ZZ	6002 2RU	6002 2RD	6002 2RS	17	18.5	30	0.3	0.03
17	35	10	0.3	7.5	3.25	0.17	14.4	21 000	19 000	12 000	6003	-	6003 ZZ	6003 2RU	6003 2RD	6003 2RS	19	21	33	0.3	0.039
20	42	12	0.6	11.7	5.05	0.35	13.9	17 000	15 000	10 000	6004	-	6004 ZZ	6004 2RU	6004 2RD	6004 2RS	24	25	38	0.6	0.069
25	47	12	0.6	12.6	5.85	0.38	14.5	15 000	14 000	9 000	6005	-	6005 ZZ	6005 2RU	6005 2RD	6005 2RS	29	29.5	43	0.6	0.08
30	55	13	1	16.5	8.25	0.53	14.7	13 000	12 000	7 500	6006	-	6006 ZZ	6006 2RU	6006 2RD	6006 2RS	35	36	50	1	0.116
35	62	14	1	19.9	10.3	0.64	14.9	11 000	9 900	6 500	6007	-	6007 ZZ	6007 2RU	6007 2RD	6007 2RS	40	42	58	1	0.155
40	68	15	1	20.9	11.5	0.69	15.2	10 000	9 000	5 800	6008	-	6008 ZZ	6008 2RU	6008 2RD	6008 2RS	45	46.5	63	1	0.192
45	75	16	1	26.2	15.1	0.9	15.3	9 200	8 300	5 300	6009	6009	6009 ZZ	6009 2RU	6009 2RD	6009 2RS	50	51.5	70	1	0.245
50	80	16	1	27.3	16.6	0.96	15.6	8 400	7 600	4 800	6010	-	6010 ZZ	6010 2RU	6010 2RD	6010 2RS	55	57	75	1	0.261
55	90	18	1.1	35.3	21.2	1.25	15.3	7 600	6 800	4 300	6011	-	6011 ZZ	6011 2RU	6011 2RD	6011 2RS	61.5	62	83.5	1	0.385
60	95	18	1.1	36.8	23.2	1.35	15.6	7 100	-	4 000	6012	-	6012 ZZ	6012 2RU	6012 2RD	6012 2RS	66.5	68.5	88.5	1	0.415
65	100	18	1.1	38.1	25.2	1.4	15.8	7 600	-	3 700	6013	-	6013 ZZ	6013 2RU	-	6013 2RS	71.5	74.5	93.5	1	0.435
70	110	20	1.1	47.6	30.9	1.8	15.6	7 100	-	3 500	6014	-	6014 ZZ	6014 2RU	-	6014 2RS	76.5	79.5	103.5	1	0.602
75	115	20	1.1	49.4	33.5	1.9	15.8	6 700	-	3 300	6015	-	6015 ZZ	6015 2RU	-	6015 2RS	81.5	84.5	108.5	1	0.638
80	125	22	1.1	59.5	39.8	2.25	15.6	5 300	-	3 100	6016	-	6016 ZZ	6016 2RU	-	6016 2RS	86.5	90	118.5	1	0.85
85	130	22	1.1	61.8	43.1	2.35	15.8	5 000	-	2 900	6017	-	6017 ZZ	6017 2RU	-	6017 2RS	91.5	96.5	123.5	1	0.89
90	140	24	1.5	72.8	49.7	2.65	15.6	4 700	-	2 700	6018	-	6018 ZZ	6018 2RU	-	6018 2RS	98	100.5	132	1.5	1.16
95	145	24	1.5	75.5	53.9	2.75	15.8	4 400	-	2 500	6019	-	6019 ZZ	6019 2RU	-	6019 2RS	103	107.5	137	1.5	1.21
100	150	24	1.5	75.2	54.2	2.7	15.9	4 300	-	2 500	6020	-	6020 ZZ	6020 2RU	-	6020 2RS	108	112	142	1.5	1.25
105	160	26	2	90.4	65.8	3.2	15.8	4 000	-	2 300	6021	-	6021 ZZ	6021 2RU	-	6021 2RS	114	119	151	2	1.59
110	170	28	2	103	73	3.55	15.6	3 800	-	2 200	6022	-	6022 ZZ	6022 2RU	-	6022 2RS	119	123	161	2	1.96
120	180	28	2	106	79.3	3.6	15.9	3 600	-	2 100	6024	-	6024 ZZ	6024 2RU	-	6024 2RS	129	136	171	2	2.07
130	200	33	2	133	101	4.45	15.8	3 200	-	1 900	6026	-	6026 ZZ	6026 2RU	-	6026 2RS	139	146.5	191	2	3.16
130	200	33	-	-	-	-	-	-	-	-		-	-	-	-	-	-	-	-	-	-
140	210	33	2	137	109	4.55	15.9	3 000	-	1 800	6028	-	6028 ZZ	6028 2RU	-	6028 2RS	149	158.5	201	2	3.55
150	225	35	2.1	157	126	5.1	16	2 800	-	1 600	6030	-	6030 ZZ	6030 2RU	-	6030 2RS	161	168.5	214	2	4.22

* Not a stocked range although available on request.

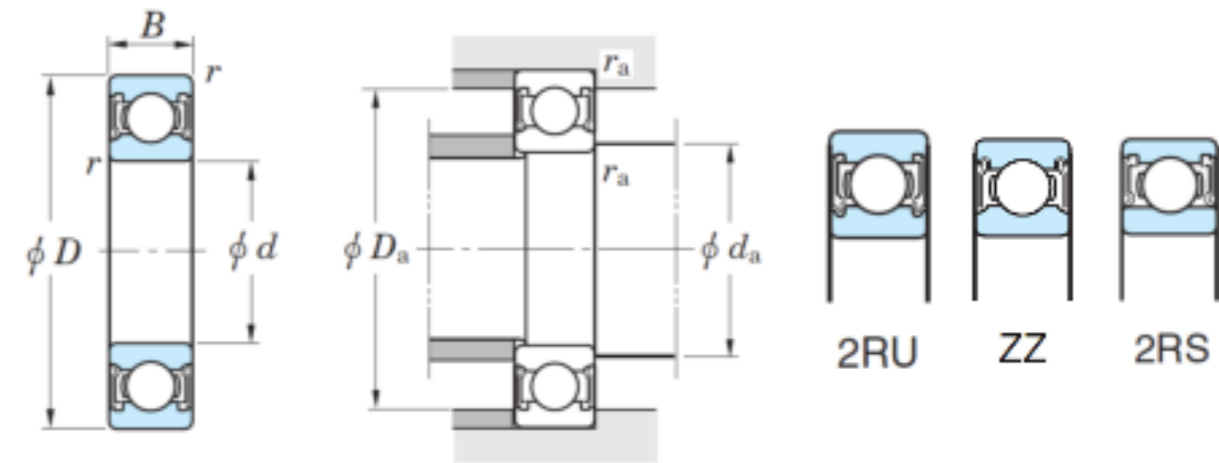
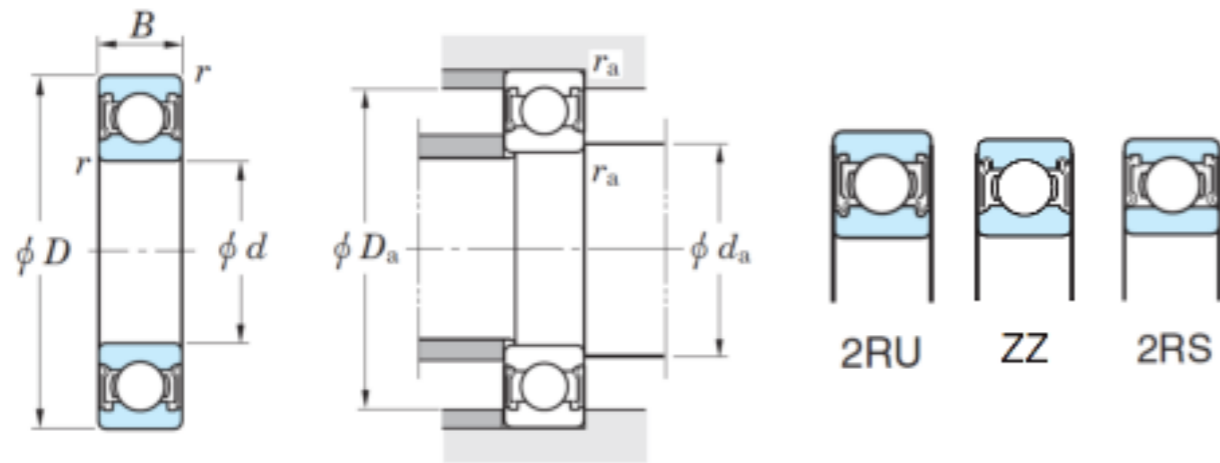

Boundary dimensions(mm)				Basic load ratings(kN)		Fatigue load limit(kN)	Factor	Limiting speeds(min-1)			Bearing Ref.	Bearing No.				Mounting dimensions				Mass Open type (kg)
d	D	B	r min.	Cr	Cor	Cu	fo	Grease lub.				Shielded	Non-contact sealed*	Extremely light contact sealed*	Contact sealed	da		Da	ra	
								(Z, ZZ RU, 2RU)	(RD, 2RD)	(RS, 2RS)						min.	max.			
10	30	9	0.6	6.4	2.4	0.12	13.2	24 000	22 000	16 000	6200	6200 ZZ	6200 2RU	6200 2RD	6200 2RS	14	15	26	0.6	0.032
12	32	10	0.6	8.5	3.05	0.24	12.3	22 000	20 000	15 000	6201	6201 ZZ	6201 2RU	6201 2RD	6201 2RS	16	16.5	28	0.6	0.037
15	35	11	0.6	9.55	3.75	0.29	13.2	20 000	18 000	13 000	6202	6202 ZZ	6202 2RU	6202 2RD	6202 2RS	19	19.5	31	0.6	0.045
17	40	12	0.6	12	4.8	0.37	13.2	17 000	15 000	12 000	6203	6203 ZZ	6203 2RU	6203 2RD	6203 2RS	21	22	36	0.6	0.065
20	47	14	1	16	6.65	0.51	13.2	15 000	14 000	9 700	6204	6204 ZZ	6204 2RU	6204 2RD	6204 2RS	25	26.5	42	1	0.106
25	52	15	1	17.5	7.85	0.55	13.9	13 000	12 000	8 400	6205	6205 ZZ	6205 2RU	6205 2RD	6205 2RS	30	31.5	47	1	0.128
30	62	16	1	24.3	11.3	0.8	13.9	11 000	9 900	7 000	6206	6206 ZZ	6206 2RU	6206 2RD	6206 2RS	35	37.5	57	1	0.199
35	72	17	1.1	32.1	15.4	1.1	13.9	9 200	8 300	6 000	6207	6207 ZZ	6207 2RU	6207 2RD	6207 2RS	41.5	43.5	65.5	1	0.288
40	80	18	1.1	36.4	17.8	1.25	14	8 300	7 500	5 400	6208	6208 ZZ	6208 2RU	6208 2RD	6208 2RS	46.5	49	73.5	1	0.366
45	85	19	1.1	40.9	20.3	1.4	14	7 700	6 900	5 100	6209	6209 ZZ	6209 2RU	6209 2RD	6209 2RS	51.5	53.5	78.5	1	0.407
50	90	20	1.1	43.9	23.3	1.55	14.4	7 100	6 400	4 600	6210	6210 ZZ	6210 2RU	6210 2RD	6210 2RS	56.5	59	83.5	1	0.463
55	100	21	1.5	54.2	29.4	1.95	14.4	6 300	5 700	4 100	6211	6211 ZZ	6211 2RU	6211 2RD	6211 2RS	63	66	92	1.5	0.607
60	110	22	1.5	65.6	36.2	2.4	14.4	5 700	5 100	3 700	6212	6212 ZZ	6212 2RU	6212 2RD	6212 2RS	68	72.5	102	1.5	0.783
65	120	23	1.5	71.5	40.1	2.65	14.4	5 400	-	3 500	6213	6213 ZZ	6213 2RU	6213 2RD	6213 2RS	73	79	112	1.5	0.99
70	125	24	1.5	77.8	44.1	2.9	14.5	5 100	-	3 300	6214	6214 ZZ	6214 2RU	-	6214 2RS	78	84	117	1.5	1.07
75	130	25	1.5	84.3	48.3	3.1	14.5	4 800	-	3 100	6215	6215 ZZ	6215 2RU	-	6215 2RS	83	88.5	122	1.5	1.18
80	140	26	2	90.9	53	3.25	14.6	4 500	-	2 900	6216	6216 ZZ	6216 2RU	-	6216 2RS	89	93	131	2	1.4
85	150	28	2	105	61.9	3.7	14.5	4 200	-	2 700	6217	6217 ZZ	6217 2RU	-	6217 2RS	94	102	141	2	1.79
90	160	30	2	120	71.5	4.2	14.5	3 900	-	2 600	6218	6218 ZZ	6218 2RU	-	6218 2RS	99	108.5	151	2	2.15
95	170	32	2.1	136	81.9	4.65	14.4	3 700	-	2 400	6219	6219 ZZ	6219 2RU	-	6219 2RS	106	113	159	2	2.62
100	180	34	2.1	153	93.1	5.15	14.4	3 500	-	2 300	6220	6220 ZZ	6220 2RU	-	6220 2RS	111	122	169	2	3.14
105	190	36	2.1	166	105	5.7	14.4	3 300	-	2 200	6221	6221 ZZ	6221 2RU	-	6221 2RS	116	127	179	2	3.7
110	200	38	2.1	180	117	6.2	14.4	3 100	-	2 000	6222	6222 ZZ	6222 2RU	-	6222 2RS	121	136.5	189	2	4.36
120	215	40	2.1	194	131	6.65	14.4	2 900	-	1 900	6224	6224 ZZ	6224 2RU	-	6224 2RS	131	144	204	2	5.15
150	270	45	3	220	168	9.05	15.1	2200	-	-	6230	6230 ZZ	-	-	-	163	183.5	257	2.5	9.41

* Not a stocked range although available on request.

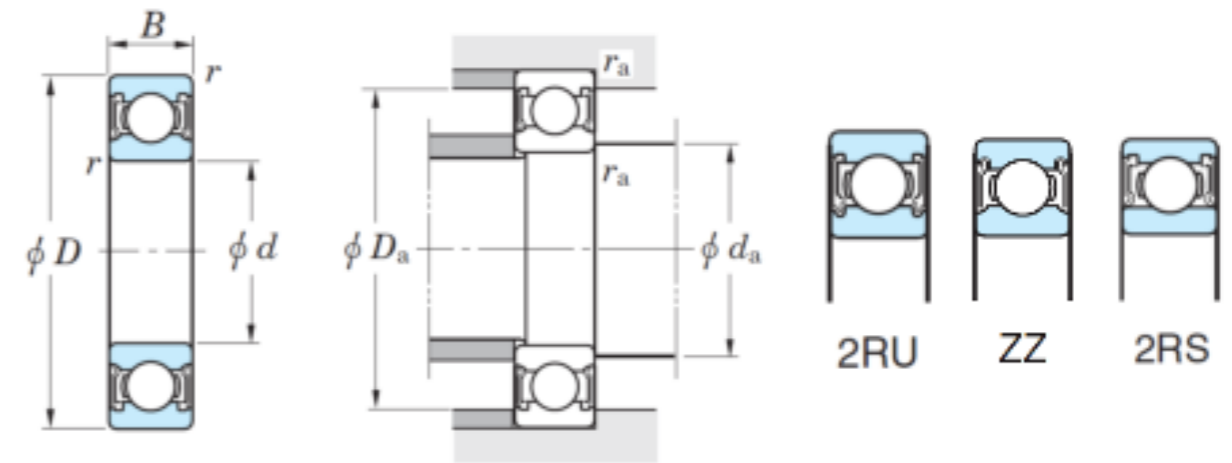
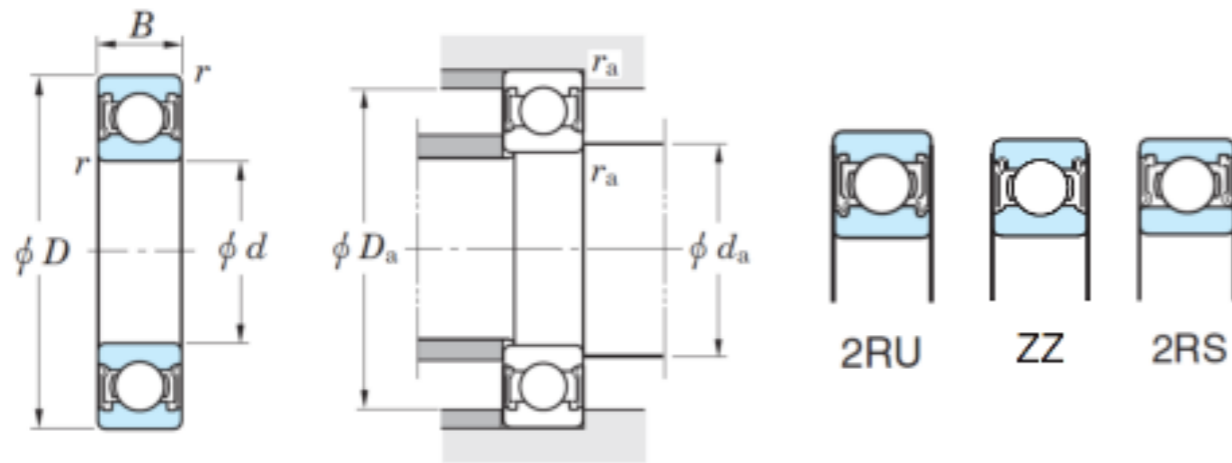

Boundary dimensions(mm)				Basic load ratings(kN)		Fatigue load limit(kN)	Factor	Limiting speeds(min-1)			Bearing No.	Mounting dimensions				Mass Open type (kg)				
d	D	B	r min.	Cr	Cor	Cu	fo	Grease lub.				Shielded	Non-contact sealed*	Extremely light contact sealed*	Contact sealed					
								(Z, ZZ RU, 2RU)	(RD, 2RD)	(RS, 2RS)							Bearing Ref.	da min.	da max.	Da max.
10	35	11	0.6	10.1	3.45	0.27	11.2	22 000	20 000	16 000	6300	6300 ZZ	6300 2RU	6300 2RD	6300 2RS	14	16	31	0.6	0.053
12	37	12	1	12.1	4.2	0.42	11.1	20 000	18 000	15 000	6301	6301 ZZ	6301 2RU	6301 2RD	6301 2RS	17	17.5	32	1	0.06
15	42	13	1	14.3	5.45	0.46	12.3	17 000	15 000	12 000	6302	6302 ZZ	6302 2RU	6302 2RD	6302 2RS	20	21.5	37	1	0.082
17	47	14	1	17	6.65	0.55	12.4	15 000	14 000	10 000	6303	6303 ZZ	6303 2RU	6303 2RD	6303 2RS	22	24.3	42	1	0.115
20	52	15	1.1	19.9	7.85	0.66	12.3	14 000	13 000	9 500	6304	6304 ZZ	6304 2RU	6304 2RD	6304 2RS	26.5	27	45.5	1	0.144
25	62	17	1.1	25.7	11.3	0.86	13.2	11 000	9 900	7 500	6305	6305 ZZ	6305 2RU	6305 2RD	6305 2RS	31.5	34	55.5	1	0.232
30	72	19	1.1	33.3	15	1.15	13.3	9 600	8 600	6 400	6306	6306 ZZ	6306 2RU	6306 2RD	6306 2RS	36.5	40	65.5	1	0.346
35	80	21	1.5	41.7	19.3	1.45	13.2	8 500	7 700	5 700	6307	6307 ZZ	6307 2RU	6307 2RD	6307 2RS	43	46	72	1.5	0.457
40	90	23	1.5	50.9	24	1.85	13.2	7 700	6 900	5 100	6308	6308 ZZ	6308 2RU	6308 2RD	6308 2RS	48	51.5	82	1.5	0.633
45	100	25	1.5	61.1	29.5	2.25	13.3	6 800	6 100	4 500	6309	6309 ZZ	6309 2RU	6309 2RD	6309 2RS	53	59.5	92	1.5	0.833
50	110	27	2	77.5	38.3	2.9	13.2	6 100	5 500	4 100	6310	6310 ZZ	6310 2RU	6310 2RD	6310 2RS	59	66.5	101	2	1.07
55	120	29	2	89.5	45	3.45	13.2	5 600	-	3 700	6311	6311 ZZ	6311 2RU	-	6311 2RS	64	74.5	111	2	1.37
60	130	31	2.1	102	52.2	3.95	13.2	5 200	-	3 500	6312	6312 ZZ	6312 2RU	-	6312 2RS	71	80	119	2	1.7
65	140	33	2.1	116	59.9	4.5	13.2	4 800	-	3 200	6313	6313 ZZ	6313 2RU	-	6313 2RS	76	86	129	2	2.08
70	150	35	2.1	130	68.2	4.95	13.2	4 500	-	3 000	6314	6314 ZZ	6314 2RU	-	6314 2RS	81	92	139	2	2.52
75	160	37	2.1	142	77.2	5.4	13.2	4 200	-	2 800	6315	6315 ZZ	6315 2RU	-	6315 2RS	86	97.5	149	2	3.02
80	170	39	2.1	154	86.7	5.85	13.3	3 900	-	2 700	6316	6316 ZZ	6316 2RU	-	6316 2RS	91	105	159	2	3.59
85	180	41	3	166	96.8	6.35	13.3	3 700	-	2 500	6317	6317 ZZ	6317 2RU	-	6317 2RS	98	111	167	2.5	4.23
90	190	43	3	178	107	8.8	13.3	3 500	-	2 400	6318	6318 ZZ	6318 2RU	-	6318 2RS	103	117	177	2.5	4.91
95	200	45	3	191	119	9.45	13.3	3 300	-	2 200	6319	6319 ZZ	6319 2RU	-	6319 2RS	108	122	187	2.5	5.67
100	215	47	3	216	141	10.9	13.2	3 000	-	2 100	6320	6320 ZZ	6320 2RU	-	6320 2RS	113	131	202	2.5	7
105	225	49	3	230	153	11.7	13.2	2 900	-	-	6321	6321 ZZ	6321 2RU	6321 2RD	6321 2RS	118	-	212	2.5	8.05
110	240	50	3	257	180	13.3	13.2	2 700	-	-	6322	6322 ZZ	6322 2RU	6322 2RD	6322 2RS	123	-	227	2.5	9.54
120	260	55	3	258	185	12.6	13.5	2 500	-	-	6324	6324 ZZ	6324 2RU	6324 2RD	6324 2RS	133	-	247	2.5	12.5

* Not a stocked range although available on request.

d	D	B	Bearing No.	Type
17	62	17	6403-ZZ	Metal Shields
20	72	19	6404-ZZ	Metal Shields
25	80	21	6405-ZZ	Metal Shields
30	90	23	6406-ZZ	Metal Shields
35	100	25	6407-ZZ	Metal Shields
40	110	27	6408-ZZ	Metal Shields
45	120	29	6409-ZZ	Metal Shields
45	120	29	6409C3	Open
50	130	31	6410-ZZ	Metal Shields
55	140	33	6411C3	Open
65	160	37	6413NRC3	Open w/Snap Ring

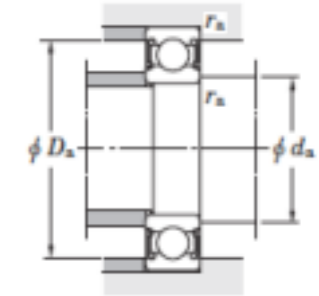
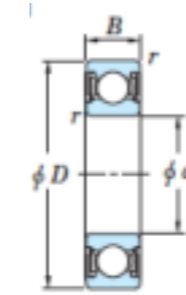

Z



ZX



RU



2RU



RD



RS



2RS



2RD



2RS

Shielded

Non-contact sealed

Extremely light contact sealed

Contact sealed

Deep Groove Ball Bearings

60/62/63 Series

Boundary dimensions(mm)				Basic load ratings(kN)		Fatigue load limit(kN)	Factor	Limiting speeds(min-1)			Bearing No.	Mounting dimensions				Mass Open type (kg)					
d	D	B	r min.	Cr	Cor	Cu	fo	Grease lub.				Open	Shielded*	Non-contact sealed*	Extremely light contact sealed*		Contact sealed	da		Da	ra
								(Z, ZZ, RU, 2RU)	(RD, 2RD)	(RS, 2RS)								min.	max.		
22	44	12	0.6	11.7	5.15	0.350	14.1	17000	15000	9900	60/22	-	60/22 ZZ	60/22 2RU	60/22 2RD	60/22 2RS	26	26.5	40	0.6	0.073
28	52	12	0.6	15.6	7.4	0.480	14.5	14000	13000	8100	60/28	-	60/28 ZZ	60/28 2RU	60/28 2RD	60/28 2RS1	32	33	48	0.6	0.097
32	58	13	1	18.8	9.15	0.600	14.5	12000	11000	7200	60/32	-	60/32 ZZ	60/32 2RU	60/32 2RD	60/32 2RS	37	38	53	1	0.127
22	50	14	1	16.0	6.65	0.510	13.2	14000	9700	17000	62/22	-	62/22 ZZ	62/22 2RU	62/22 2RD	62/22 2RS	27	27	45	1	0.118
28	58	16	1	22.4	9.75	0.720	13.4	12000	11000	7600	62/28	-	62/28 ZZ	62/28 2RU	62/28 2RD	62/28 2RS	33	35	53	1	0.173
32	65	17	1	29.4	13.1	0.990	13.3	10000	9000	6900	62/32	-	62/32 ZZ	62/32 2RU	62/32 2RD	62/32 2RS	37	38.5	60	1	0.228
22	56	16	-	-	-	-	-	-	-	-	63/22	-	-	-	-	63/22 2RK	-	-	-	-	-
28	68	18	1.1	29.4	13.1	0.990	13.3	10000	9000	6900	63/28	-	63/28 ZZ	63/28 2RU	63/28 2RD	63/28 2RS	34.5	37.5	61.5	1	0.328
32	75	20	1.1	37.6	16.2	1.30	12.7	9300	8400	6400	63/32	-	63/32 ZZ	63/32 2RU	63/32 2RD	63/32 2RS	38.5	41	68.5	1	0.437

* Not a stocked range although available on request.

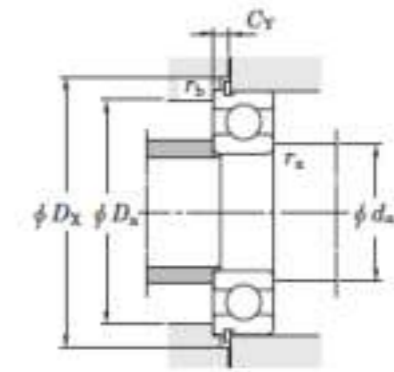
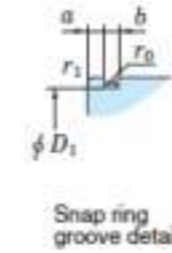
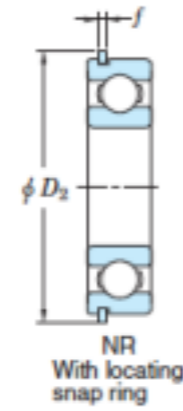
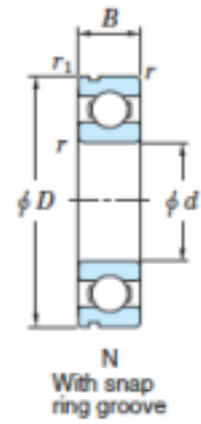

Boundary dimensions(mm)					Basic load ratings(kN)		Fatigue load limit(kN)	Factor	Limiting speeds(min-1)			Bearing No.	Mounting dimensions					Mass (kg)		
d	D	B	r min.	r1 min.	Cr	Cor	Cu	fo	Grease lub.	Oil lub.	Bearing Ref.		Snap ring groove*	Locating snap ring	da min.	Da max.	Dx min.		Cy max.	ra max.
22	50	14	1	0.5	16.0	6.65	0.510	13.2	15000	17000	62/22	62/22 N	62/22 NR	27	45	56.5	3.33	1	0.5	0.118
28	58	16	1	0.5	22.4	9.75	0.720	13.4	12000	14000	62/28	62/28 N	62/28 NR	33	53	64.5	3.33	1	0.5	0.173
22	56	16	1.1	0.5	23.1	9.40	0.770	12.6	13000	15000	63/22	63/22 N	63/22 NR	28.5	49.5	62.5	3.33	1	0.5	0.201
32	75	20	1.1	0.5	37.6	16.2	1.30	12.7	9300	11000	63/32	63/32 N	63/32 NR	38.5	68.5	83	4.67	1	0.5	0.437

* Not a stocked range although available on request.

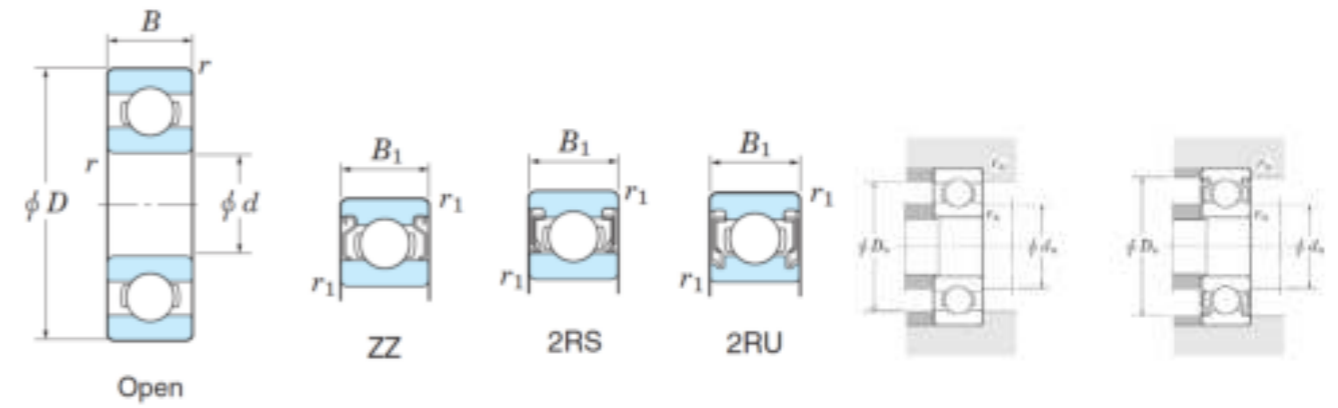
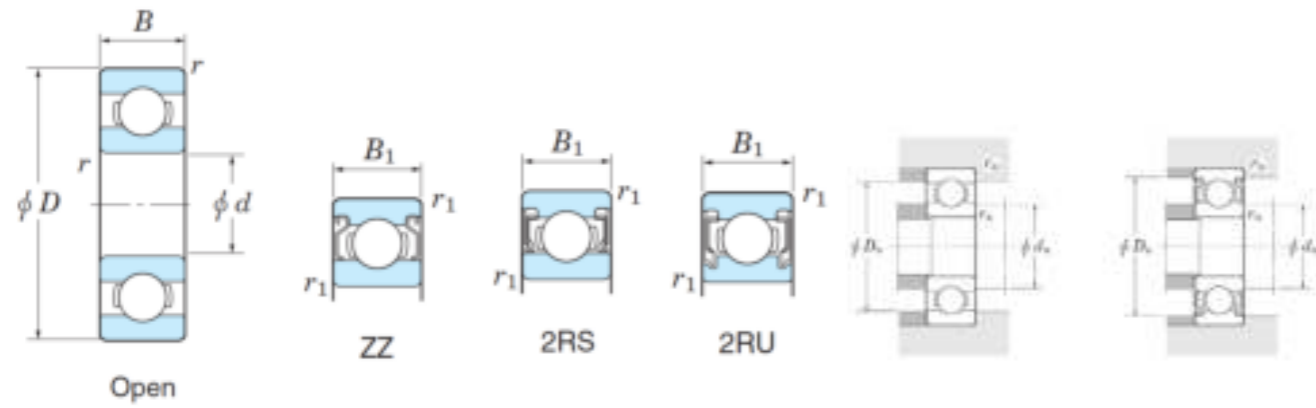

Boundary dimensions(mm)				Basic load ratings(kN)		Fatigue load limit(kN)	Factor	Limiting speeds(min-1)			Bearing No.	Mounting dimensions			Mass Open type (g)					
d	D	B	r1 min.	Cr	Cor	Cu	fo	Grease lub.				Open*	Shielded	Non-contact sealed*		Extremely light contact sealed*	Contact sealed*	da min.	Da max.	ra max.
								(ZZ,2RU)	(2RD)	(2RS)										
4	12	4	0.2	1.2	0.35	0.009	12.4	53 000	-	-	604	604	604 ZZ	-	-	-	5.6	10.4	0.2	2.1
5	14	5	0.2	1.65	0.49	0.010	12.3	-	-	-	605	605	605 ZZ	-	-	605 2RS	-	12.4	0.2	3.5
6	17	6	0.3	2.45	0.74	0.03	12.2	43 000	39 000	-	606	606	606 ZZ	606 2RU	606 2RD	-	8	15	0.3	5.8
7	19	6	0.3	2.95	0.89	0.04	12.3	40 000	36 000	27 000	607	607	607 ZZ	607 2RU	607 2RD	607 2RS	9	17	0.3	7.6
8	22	7	0.3	4.1	1.35	0.06	12.4	34 000	31 000	23 000	608	608	608 ZZ	608 2RU	608 2RD	608 2RS	10	20	0.3	12
9	24	7	0.3	4.15	1.4	0.06	12.8	33 000	30 000	22 000	609	609	609 ZZ	609 2RU	609 2RD	609 2RS	11	22	0.3	15
4	12	4	0.2	1.2	0.35	0.009	12.4	53 000	-	-	624	624	624 ZZ	624 2RU	-	624 2RS	5.6	11.4	0.2	2.9
5	16	5	0.3	2.15	0.67	0.03	12.4	40 000	36 000	33 000	625	625	625 ZZ	625 2RU	-	625 2RS	7	14	0.3	5
6	19	6	0.3	2.9	0.89	0.04	12.3	35 000	32 000	27 000	626	626	626 ZZ	626 2RU	626 2RD	626 2RS	8	17	0.3	8.1
7	22	7	0.3	4.1	1.35	0.060	12.4	31000	28000	23000	627	627	627 ZZ	627 RU	627 2RD	627 2RS	9	20	0.3	13
8	24	8	0.3	4.15	1.4	0.06	12.8	28 000	-	22 000	628	628	628 ZZ	628 2RU	-	628 2RS	10	22	0.3	18
9	26	8	0.6	5.7	1.95	0.1	12.4	27 000	24 000	19 000	629	629	629 ZZ	629 2RU	629 2RD	629 2RS	12.1	22	0.3	20
5	19	6	0.3	2.9	0.89	0.04	12.3	35 000	32 000	27 000	635	635	635 ZZ	635 2RU	-	635 2RS	7	17	0.3	8.5
6	22	7	0.3	4.1	1.35	0.06	12.4	31 000	-	23 000	636	636	636 ZZ	-	-	636 2RS	8	20	0.3	13
8	28	9	0.3	5.65	1.95	0.1	12.3	26 000	23 000	-	638	638	638 ZZ	-	638 2RD	-	10	26	0.3	29

* Not a stocked range although available on request.

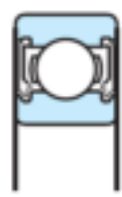
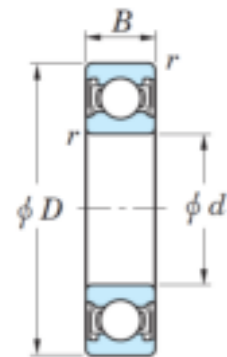

2RU

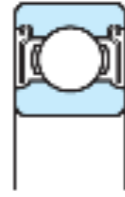

ZZ

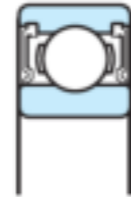

2RS

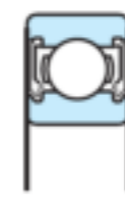
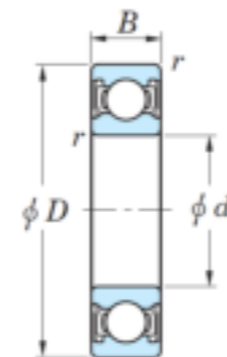
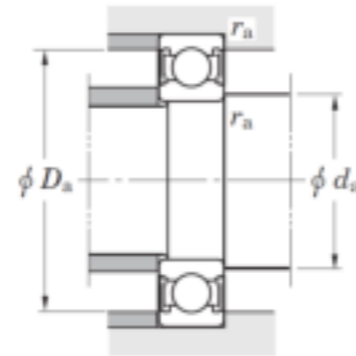

2RU



ZZ

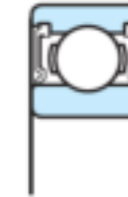

2RS

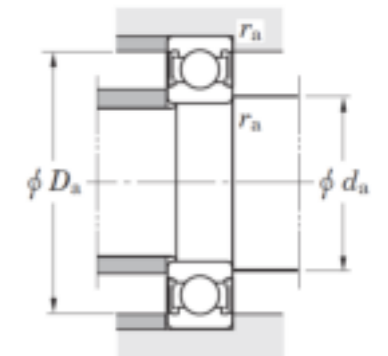

Boundary dimensions(mm)				Basic load ratings(kN)		Fatigue load limit(kN)	Factor	Limiting speeds(min-1)			Bearing No.	Mounting dimensions				Mass Open type (kg)				
d	D	B	r min.	C _r	C _{or}	C _u	f _o	Grease lub.				Shielded*	Non-contact sealed	Extremely light contact sealed*	Contact sealed*		d _a		D _a	r _a
								(Z, ZZ RU, 2RU)	(RD, 2RD)	(RS, 2RS)							min.	max.		
10	19	5	0.3	2.15	0.840	0.030	14.8	37000	-	22000	6800	6800 ZZ	6800 2RU	-	6800 2RS	12	12	17	0.3	0.005
12	21	5	0.3	2.40	1.05	0.040	15.3	33000	30000	20000	6801	6801 ZZ	6801 2RU	6801 2RD	6801 2RS	14	14	19	0.3	0.006
15	24	5	0.3	2.60	1.25	0.050	15.8	28000	-	16000	6802	6802 ZZ	6802 2RU	-	6802 2RS	17	17	22	0.3	0.007
17	26	5	0.3	3.30	1.55	0.060	15.7	26000	-	14000	6803	6803 ZZ	6803 2RU	-	6803 2RS	19	19	24	0.3	0.008
20	32	7	0.3	5.00	2.45	0.100	15.5	21000	-	12000	6804	6804 ZZ	6804 2RU	-	6804 2RS	22	22.5	30	0.3	0.018
25	37	7	0.3	5.40	2.95	0.120	16.0	18000	-	10000	6805	6805 ZZ	6805 2RU	-	6805 2RS	27	27.5	35	0.3	0.022
30	42	7	0.3	5.65	3.40	0.140	16.4	15000	-	8600	6806	6806 ZZ	6806 2RU	-	6806 2RS	32	32.5	40	0.3	0.026
35	47	7	0.3	5.95	3.85	0.160	16.5	13000	-	7400	6807	6807 ZZ	6807 2RU	-	6807 2RS	37	37.5	45	0.3	0.030
40	52	7	0.3	6.15	4.20	0.180	16.3	12000	11000	6700	6808	6808 ZZ	6808 2RU	6808 2RD	6808 2RS	42	42	50	0.3	0.033
45	58	7	0.3	7.75	5.4	0.23	16.3	11000	9900	5900	6809	6809 ZZ	6809 2RU	6809 2RD	6809 2RS	47	47	56	0.3	0.04
50	65	7	0.3	8.2	6.1	0.26	16.1	9600	8600	5200	6810	6810 ZZ	6810 2RU	6810 2RD	6810 2RS	52	53	63	0.3	0.052
55	72	9	0.3	11	8.1	0.42	16.2	8700	7800	-	6811	6811 ZZ	6811 2RU	6811 2RD	6811 2RS	57	58.5	70	0.3	0.083
60	78	10	0.3	14.3	10.6	0.55	16.3	8000	7200	-	6812	6812 ZZ	6812 2RU	6812 2RD	6812 2RS	62	63	76	0.3	0.104
65	85	10	0.6	14.9	11.5	0.59	16.2	7300	6600	-	6813	6813 ZZ	6813 2RU	6813 2RD	6813 2RS	69	69	81	0.6	0.126
70	90	10	0.6	15.1	11.9	0.62	16.1	6800	6100	-	6814	6814 ZZ	6814 2RU	6814 2RD	6814 2RS	74	74	86	0.6	0.134
75	95	10	0.6	15.7	12.9	0.66	16	6400	5800	-	6815	6815 ZZ	6815 2RU	6815 2RD	6815 2RS	79	79	91	0.6	0.142
80	100	10	0.6	15.9	13.3	0.69	16	6100	5500	-	6816	6816 ZZ	6816 2RU	6816 2RD	6816 2RS	84	84	96	0.6	0.15
85	110	13	1	23.4	19	0.98	16.2	5600	5000	-	6817	6817 ZZ	6817 2RU	6817 2RD	6817 2RS	90	90.5	105	1	0.266
90	115	13	1	23.8	19.7	1	16.1	5300	4800	-	6818	6818 ZZ	6818 2RU	6818 2RD	6818 2RS	95	95.5	110	1	0.279
100	125	13	1	24.5	21.2	1.05	16	4800	4300	-	6820	6820 ZZ	6820 2RU	6820 2RD	6820 2RS	105	105.5	120	1	0.309
110	140	16	1	35.1	30.7	1.4	16.1	4300	3900	-	6822	6822 ZZ	6822 2RU	6822 2RD	6822 2RS	115	116.5	135	1	0.606

* Not a stocked range although available on request.

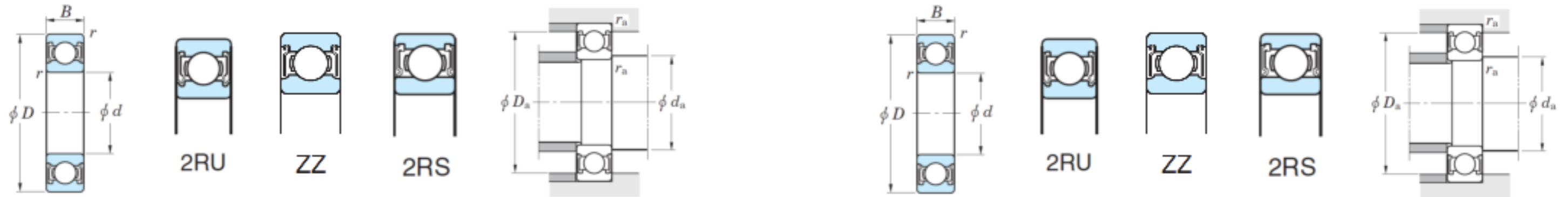

Boundary dimensions(mm)				Basic load ratings(kN)		Fatigue load limit(kN)	Factor	Limiting speeds(min-1)			Bearing Ref.	Bearing No.				Mounting dimensions (mm)				Mass Open type (kg)
d	D	B	r min.	Cr	Cor	Cu	fo	Grease lub.				Shielded	Non-contact sealed	Extremely light contact sealed*	Contact sealed	da		Da	ra	
								(Z, ZZ RU, 2RU)	(RD, 2RD)	(RS, 2RS)						min.	max.			
10	22	6	0.3	3.35	1.25	0.070	14.0	34000	-	21000	6900	6900 ZZ	6900 2RU	-	6900 2RS	12	12.5	20	0.3	0.010
12	24	6	0.3	3.60	1.45	0.080	14.5	31000	28000	18000	6901	6901 ZZ	6901 2RU	6901 2RD	6901 2RS	14	14	22	0.3	0.011
15	28	7	0.3	5.40	2.25	0.120	14.3	26000	23000	15000	6902	6902 ZZ	6902 2RU	6902 2RD	6902 2RS	17	18	26	0.3	0.017
17	30	7	0.3	5.75	2.55	0.130	14.7	23000	21000	13000	6903	6903 ZZ	6903 2RU	6903 2RD	6903 2RS	19	19.5	28	0.3	0.018
20	37	9	0.3	7.95	3.70	0.190	14.7	19000	17000	11000	6904	6904 ZZ	6904 2RU	6904 2RD	6904 2RS	22	23.5	35	0.3	0.036
25	42	9	0.3	8.75	4.55	0.230	15.4	16000	14000	9300	6905	6905 ZZ	6905 2RU	6905 2RD	6905 2RS	27	29	40	0.3	0.041
30	47	9	0.3	9.05	5.00	0.260	15.8	14000	13000	8200	6906	6906 ZZ	6906 2RU	6906 2RD	6906 2RS	32	33	45	0.3	0.045
35	55	10	0.6	13.6	7.75	0.440	15.7	12000	11000	6800	6907	6907 ZZ	6907 2RU	6907 2RD	6907 2RS	39	40	51	0.6	0.073
40	62	12	0.6	17.1	9.95	0.570	15.6	11000	9900	6100	6908	6908 ZZ	6908 2RU	6908 2RD	6908 2RS	44	44.5	58	0.6	0.112
45	68	12	0.6	17.7	10.9	0.600	15.9	9700	8700	5500	6909	6909 ZZ	6909 2RU	6909 2RD	6909 2RS	49	50	64	0.6	0.132
50	72	12	0.6	18.2	11.7	0.640	16.1	9000	-	5000	6910	6910 ZZ	6910 2RU	-	-	54	55.5	68	0.6	0.133
55	80	13	1	20.8	14.1	0.760	16.2	8100	7300	4500	6911	6911 ZZ	6911 2RU	6911 2RD	6911 2RS	60	60.5	75	1	0.185
60	85	13	1	25.2	17.3	0.940	16.2	7500	-	-	6912	6912 ZZ	6912 2RU	-	-	65	66	80	1	0.192
65	90	13	1	21.7	16.1	0.830	16.6	7100	6400	3900	6913	6913 ZZ	6913 2RU	6913 2RD	6913 2RS	70	71	85	1	0.211
70	100	16	1	29.7	21.2	1.1	16.3	6400	5800	3600	6914	6914 ZZ	6914 2RU	6914 2RD	6914 2RS	75	76.5	95	1	0.342
75	105	16	1	30.5	22.6	1.20	16.5	6100	-	-	6915	6915 ZZ	6915 2RU	-	6915 2RS	80	82.5	100	1	0.363
80	110	16	1	31.2	24	1.25	16.6	5700	5100	3200	6916	6916 ZZ	6916 2RU	6916 2RD	6916 2RS	85	86.5	105	1	0.382
85	120	18	1.1	39.9	29.6	1.55	16.4	5300	4800	3000	6917	6917 ZZ	6917 2RU	6917 2RD	6917 2RS	91.5	92.5	113.5	1	0.535
90	125	18	1.1	41	31.6	1.6	16.5	5100	4600	2800	6918	6918 ZZ	6918 2RU	6918 2RD	6918 2RS	96.5	97.5	118.5	1	0.565
100	140	20	1.1	51.5	39.6	1.90	16.2	4500	-	-	6920	6920 ZZ	6920-1 2RU	-	6920-2RS	106.5	110.5	133.5	1	0.960
110	150	20	1.1	59.9	47.8	2.20	16.4	4100	-	-	6922	6922 ZZ	6922 2RU	-	-	116.5	119.5	143.5	1	1.04
120	165	22	1.1	71.6	56.9	2.50	16.4	3800	-	-	6924	6924 ZZ	6924 2RU	-	-	126.5	131.5	158.5	1	1.41

* Not a stocked range although available on request.

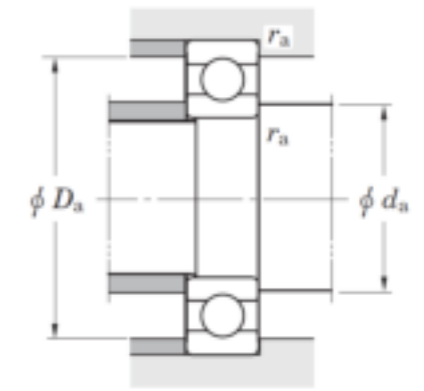
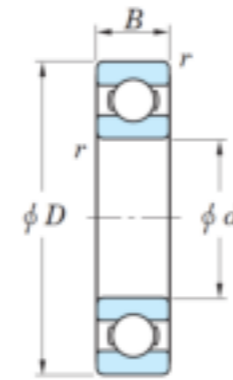
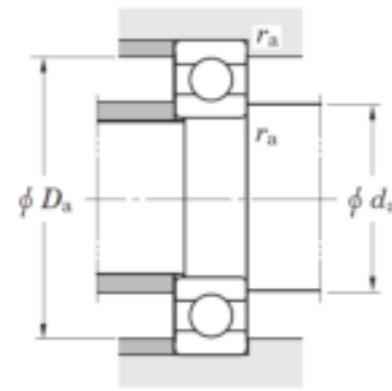
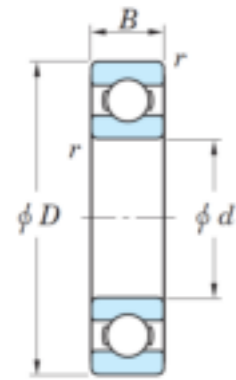

Boundary dimensions(mm)				Basic load ratings(kN)		Fatigue load limit(kN)	Factor	Limiting speeds(min-1)		Bearing No.	Mounting dimensions(mm)			Mass(kg)
d	D	B	r min.	Cr	Cor	Cu	fo	Grease lub.	Oil lub.		da(min)	Da(max)	ra(max)	
15	32	8	0.3	7	2.85	0.15	13.9	23 000	28 000	16002	17	30	0.3	0.025
17	35	8	0.3	7.5	3.25	0.17	14.4	21 000	25 000	16003	19	33	0.3	0.032
20	42	8	0.3	9.9	4.5	0.29	14.4	17 000	21 000	16004	22	40	0.3	0.05
25	47	8	0.3	11.1	5.6	0.34	15.1	15 000	18 000	16005	27	45	0.3	0.06
30	55	9	0.3	14.1	7.35	0.44	15.2	13 000	15 000	16006	32	53	0.3	0.085
35	62	9	0.3	15.3	8.85	0.5	15.7	11 000	13 000	16007	37	60	0.3	0.11
40	68	9	0.3	15.8	9.65	0.53	16	9 800	12 000	16008	42	66	0.3	0.125
45	75	10	0.6	19.4	12.3	0.67	16	8 900	10 000	16009	49	71	0.6	0.17
50	80	10	0.6	20	13.3	0.71	16.2	8 200	9 700	16010	54	76	0.6	0.18
55	90	11	0.6	24.2	16.3	0.88	16.2	7 400	8 800	16011	59	86	0.6	0.26
60	95	11	0.6	24.8	17.6	0.93	16.4	6 900	8 100	16012	64	91	0.6	0.28
65	100	11	0.6	21.4	16	0.83	16.5	6 600	7 800	16013	69	96	0.6	0.3
70	110	13	0.6	37.6	25.6	1.4	16	6 100	7 200	16014	74	106	0.6	0.433
75	115	13	0.6	34.4	25.3	1.35	16.4	5 700	6 700	16015	79	111	0.6	0.457
80	125	14	0.6	39.7	29.7	1.5	16.4	5 200	6 100	16016	84	121	0.6	0.597
85	130	14	0.6	40.8	31.7	1.55	16.5	4 900	5 800	16017	89	126	0.6	0.626
90	140	16	1	49.9	37	1.85	16.3	4 700	5 600	16018	95	135	1	0.848
95	145	16	1	51.5	39.6	1.9	16.4	4 500	5 300	16019	100	140	1	0.885
100	150	16	1	53	42.1	1.95	16.5	4 300	5 100	16020	105	145	1	0.91
105	160	18	1	52.3	42.2	1.9	16.5	4 100	4 800	16021	110	155	1	1.2
110	170	19	1	71.8	56.7	2.55	16.3	3 800	4 500	16022	115	165	1	1.46
120	180	19	1	79	63.3	2.75	16.4	3 600	4 200	16024	125	175	1	1.8
130	200	22	1.1	89.1	74.8	3.05	11.2	3 000	3 600	16026	136.5	193.5	1	2.69
140	210	22	1.1	82.2	71.1	2.80	16.5	2 900	3 400	16028	146.5	203.5	1	2.86

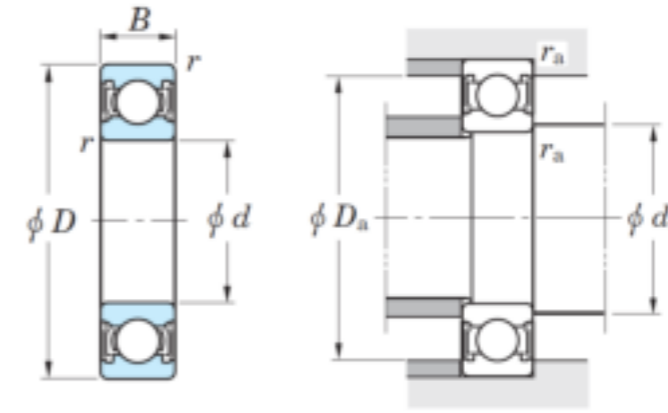
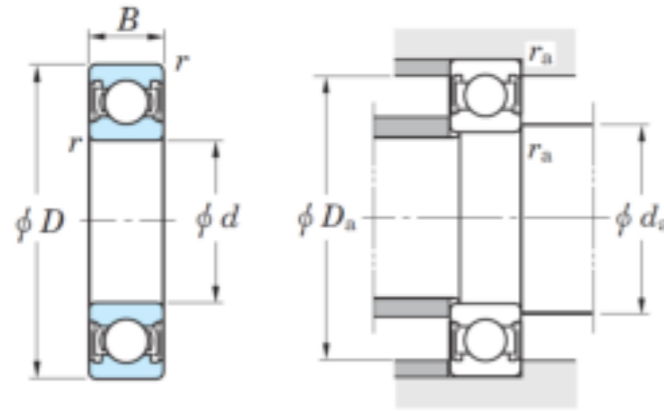

d	Boundary dimensions(mm)			Basic load ratings(kN)		Fatigue load limit(kN)	Factor	Limiting speeds(min-1)		Bearing No.	Mounting dimensions(mm)			Mass(kg)
	D	B	r min.	Cr	Cor	Cu	fo	Grease lub.	Oil lub.		da(min)	Da(max)	ra(max)	
10	26	8	0.3	5.7	1.95	0.100	12.3	31000	36000	6000	12	24	0.3	0.019
12	28	8	0.3	6.40	2.40	0.120	13.2	27000	32000	6001	14	26	0.3	0.022
15	32	9	0.3	7.00	2.85	0.150	13.9	23000	27000	6002	17	30	0.3	0.03
17	35	10	0.3	7.50	3.25	0.170	14.4	21000	25000	6003	19	33	0.3	0.039
20	42	12	0.6	11.7	5.05	0.350	13.9	17000	21000	6004	24	38	0.6	0.069
	47	14	1	19.6	7.6	0.68	12	15000	18000	6204	25	42	1	0.114
	52	15	1.1	19.9	7.85	0.660	12.3	14000	17000	6304	26.5	45.5	1	0.144
25	47	12	0.6	12.6	5.85	0.380	14.5	15000	18000	6005	29	43	0.6	0.080
	52	15	1	17.5	7.85	0.55	13.9	13000	15000	6205	30	47	1	0.128
	62	17	1.1	25.7	11.3	0.86	13.2	11000	13000	6305	31.5	55.5	1	0.232
30	55	13	1	16.5	8.25	0.530	14.7	13000	15000	6006	35	50	1	0.116
	62	16	1	24.3	11.3	0.800	13.9	11000	13000	6206	35	57	1	0.199
	72	19	1.1	33.3	15	1.15	13.3	9600	12000	6306	36.5	65.5	1	0.346
35	62	14	1	19.9	10.3	0.64	14.9	11000	13000	6007	40	58	1	0.155
	72	17	1.1	32.1	15.4	1.1	13.9	9200	11000	6207	41.5	65.5	1	0.288
	80	21	1.5	41.7	19.3	1.45	13.2	8500	10000	6307	43	72	1.5	0.457
	80	21	1.5	41.7	19.3	1.45	13.2	9500	11000	6307	43	72	1.5	0.457
40	68	15	1	20.9	11.5	0.690	15.2	10000	12000	6008	45	63	1	0.192
	80	18	1.1	36.4	17.8	1.25	14	8300	10000	6208	46.5	73.5	1	0.366
	90	23	1.5	50.9	24.0	1.85	13.2	7700	9200	6308	48	82	1.5	0.633
45	75	16	1	26.2	15.1	0.9	15.3	9200	11000	6009	50	70	1	0.245
	85	19	1.1	40.9	20.3	1.4	14	7700	9200	6209	51.5	78.5	1	0.407
	100	25	1.5	61.1	29.5	2.25	13.3	6800	8100	6309	53	92	1.5	0.833
	120	29	2	96.5	45.1	3.9	12.2	6000	7200	6409	54	111	2	1.53
50	80	16	1	27.3	16.6	0.960	15.6	8400	9900	6010	55	75	1	0.261
	90	20	1.1	43.9	23.3	1.55	14.4	7100	8500	6210	56.5	83.5	1	0.463
	110	27	2	77.5	38.3	2.90	13.2	6100	7300	6310	59	101	2	1.07
55	90	18	1.1	35.3	21.2	1.25	15.3	7600	8900	6011	61.5	83.5	1	0.385
	100	21	1.5	54.2	29.4	1.95	14.4	6300	7600	6211	63	92	1.5	0.607
	120	29	2	89.5	45.0	3.45	13.2	5600	6700	6311	64	111	2	1.37
	140	33	2.1	126	62.3	5.35	12.2	5000	6000	6411	66	129	2	2.29

* Not a stocked range although available on request.

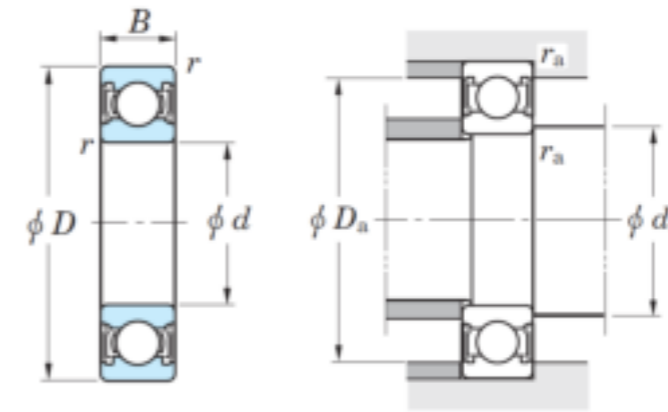
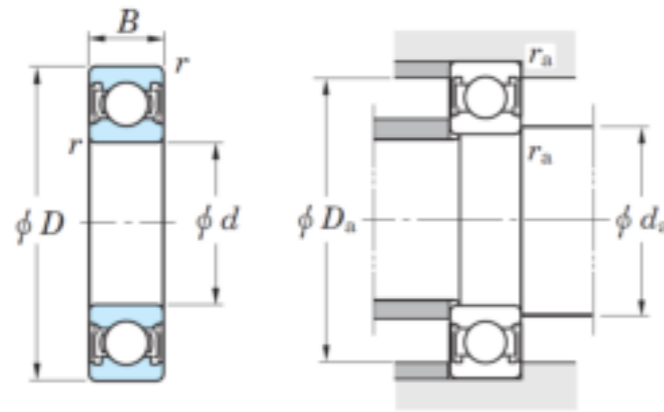

d	Boundary dimensions(mm)			Basic load ratings(kN)		Fatigue load limit(kN)	Factor	Limiting speeds(min-1)		Bearing No.	Mounting dimensions(mm)			Mass(kg)
	D	B	r min.	Cr	Cor	Cu	fo	Grease lub.	Oil lub.		da(min)	Da(max)	ra(max)	
60	95	18	1.1	36.8	23.2	1.35	15.6	7100	8400	6012	66.5	88.5	1	0.415
	110	22	1.5	65.6	36.2	2.40	14.4	5700	6900	6212	68	102	1.5	0.783
	130	31	2.1	102	52.2	3.95	13.2	5200	6200	6312	71	119	2	1.70
65	100	18	1.1	38.1	25.2	1.40	15.8	6600	7800	6013	71.5	93.5	1	0.435
	120	23	1.5	71.5	40.1	2.65	14.4	5400	6400	6213	73	112	1.5	0.990
	160	37	2.1	148	79.2	6.2	12.4	4 300	5 200	6413	76	149	2	3.3
70	110	20	1.1	47.6	30.9	1.80	15.6	6100	7200	6014	76.5	103.5	1	0.602
	125	24	1.5	77.8	44.1	2.9	14.5	5 100	6 100	6214	78	117	1.5	1.07
	150	35	2.1	130	68.2	4.95	13.2	4500	5400	6314	81	139	2	2.52
75	115	20	1.1	49.4	33.5	1.90	15.8	5700	6800	6015	81.5	108.5	1	0.638
	130	25	1.5	84.3	48.3	3.10	14.5	4800	5800	6215	83	122	1.5	1.18
	160	37	2.1	142	77.2	5.40	13.2	4200	5000	6315	86	149	2	3.02
80	125	22	1.1	59.5	39.8	2.25	15.6	5300	6300	6016	86.5	118.5	1	0.850
	140	26	2	90.9	53	3.25	14.6	4500	5400	6216	89	131	2	1.40
	170	39	2.1	154	86.7	5.85	13.3	3900	4700	6316	91	159	2	3.59
85	130	22	1.1	61.8	43.1	2.35	15.8	5000	5900	6017	91.5	123.5	1	0.890
	150	28	2	105	61.9	3.70	14.5	4200	5000	6217	94	141	2	1.79
	180	41	3	166	96.8	6.35	13.3	3700	4400	6317	98	167	2.5	4.23
90	140	24	1.5	72.8	49.7	2.65	15.6	4700	5600	6018	98	132	1.5	1.16
	160	30	2	120	71.5	4.2	14.5	3 900	4 700	6218	99	151	2	2.15
	190	43	3	178	107	8.80	13.3	3500	4200	6318	103	177	2.5	4.91
95	145	24	1.5	75.5	53.9	2.75	15.8	4400	5200	6019	103	137	1.5	1.21
	170	32	2.1	136	81.9	4.65	14.4	3700	4400	6219	106	159	2	2.62
	200	45	3	191	119	9.45	13.3	3300	4000	6319	108	187	2.5	5.67
100	150	24	1.5	75.2	54.2	2.70	15.9	4300	5100	6020	108	142	1.5	1.25
	180	34	2.1	153	93.1	5.15	14.4	3500	4200	6220	111	169	2	3.14
	215	47	3	216	141	10.9	13.2	3000	3600	6320	113	202	2.5	7.00
110	170	28	2	103	73.0	3.55	15.6	3800	4500	6022	119	161	2	1.96
	200	38	2.1	180	117	6.20	14.4	3100	3700	6222	121	189	2	4.36
	240	50	3	257	180	13.3	13.2	2700	3200	6322	123	227	2.5	9.54

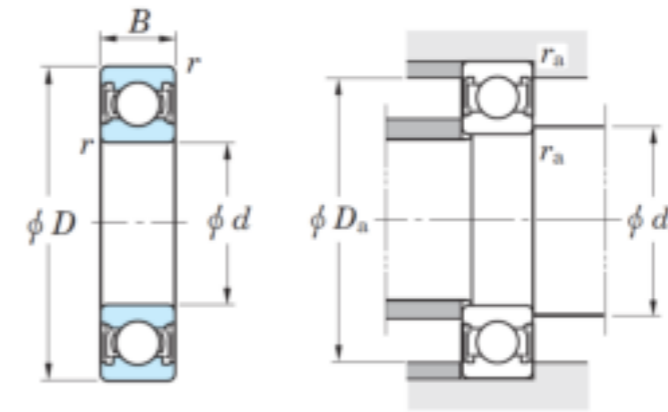
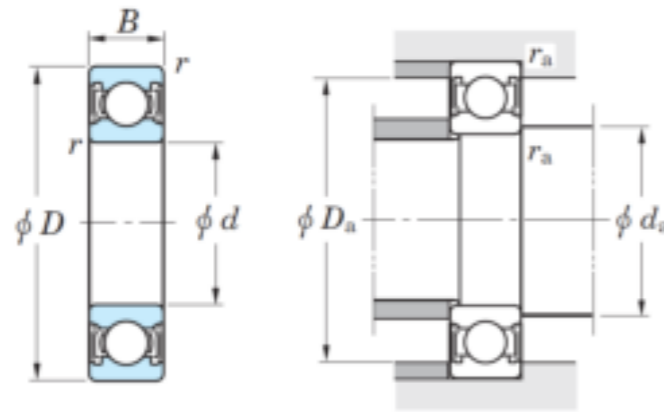

d	Boundary dimensions(mm)			Basic load ratings(kN)		Fatigue load limit(kN)	Factor	Limiting speeds(min-1)		Bearing No.	Mounting dimensions(mm)			Mass(kg)
	D	B	r min.	Cr	Cor	Cu	fo	Grease lub.	Oil lub.		da(min)	Da(max)	ra(max)	
120	180	28	2	106	79.3	3.60	15.9	3600	4200	6024	129	171	2	2.07
	215	40	2.1	194	131	6.65	14.4	2900	3400	6224	131	204	2	5.15
	260	55	3	258	185	12.6	13.5	2500	3000	6324	133	247	2.5	12.5
130	200	33	2	133	101	4.45	15.8	3200	3800	6026	139	191	2	3.16
	230	40	3	209	146	9.15	14.5	2700	3200	6226	143	217	2.5	5.82
	280	58	4	287	214	14.1	13.6	2300	2700	6326	146	264	3	15.1
140	210	33	2	137	109	4.55	15.9	3000	3600	6028	149	201	2	3.55
	250	42	3	208	150	8.65	14.8	2400	2900	6228	153	237	2.5	7.45
	300	62	4	316	246	15.6	13.6	2100	2500	6328	156	284	3	19.4
150	225	35	2.1	157	126	5.10	16.0	2800	3300	6030	161	214	2	4.22
	270	45	3	220	168	9.05	15.1	2200	2700	6230	163	257	2.5	9.41
	320	65	4	343	284	16.6	13.9	1900	2300	6330	166	304	3	26.2

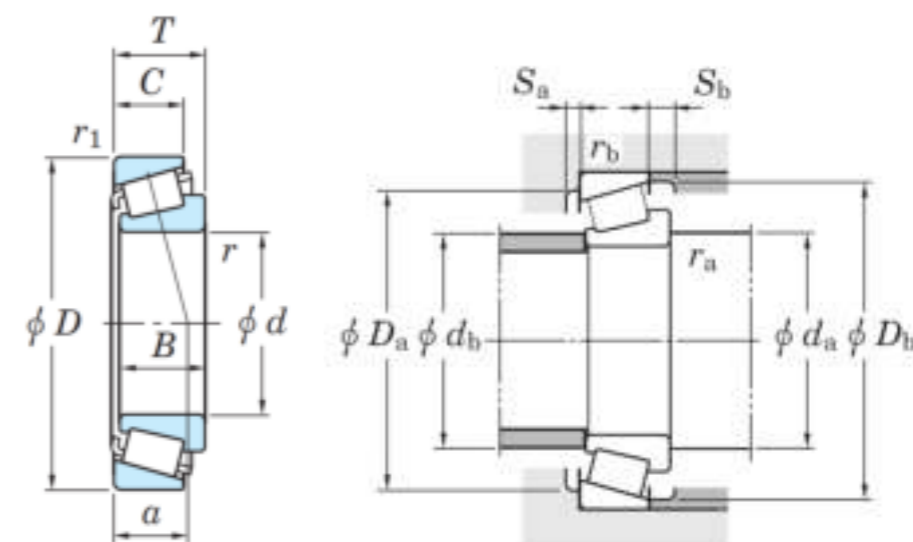
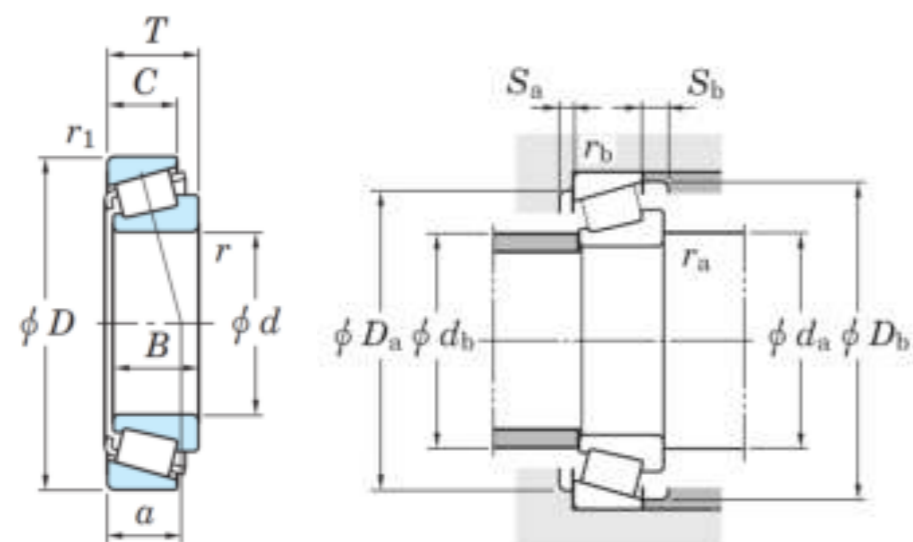

Boundary dimensions(mm)							Basic load ratings(kN)		Fatigue load limit(kN)	Limiting speeds(min-1)		Bearing No.	Dimension series to ISO355	Load center	Mounting dimensions								Constant	Axial load factors		Mass (kg)	
d	D	T	B	C	r min.	r1 min.	Cr	Cor	Cu	Grease lub.	Oil lub.				da min	db max	Da max	Db min	Sa min	Sb min	ra max	rb max		e	Y1		Y0
15	35	11.75	11	10	0.6	0.6	19.8	14.5	2.00	12000	16000	30202R	-	8.3	19.5	20	30.5	29	33	2	1.7	0.6	0.6	0.32	1.88	1.04	0.054
17	40	13.25	12	11	1	1	26	20.7	2.85	10 000	14 000	30203JR	2DB	10.1	22.5	23	34.5	33	37	2	2	1	1	0.35	1.74	0.96	0.081
20	47	15.25	14	12	1	1	33.8	27.2	3.8	8 700	12 000	30204JR	2DB	11.8	25.5	27	41.5	39	44	2	3	1	1	0.35	1.74	0.96	0.127
25	52	16.25	15	13	1	1	39.3	33.7	4.75	7 800	10 000	30205JR	3CC	12.9	30.5	31	46.5	44	48	2	3	1	1	0.37	1.6	0.88	0.156
30	62	17.25	16	14	1	1	51.8	44.8	6.45	6 500	8 700	30206JR	3DB	14.1	35.5	37	56.5	53	57	2	3	1	1	0.37	1.6	0.88	0.236
35	72	18.25	17	15	1.5	1.5	68.8	60.9	8.95	5 600	7 400	30207JR	3DB	15.3	43.5	44	63.5	62	67	3	3	1.5	1.5	0.37	1.6	0.88	0.344
40	80	19.75	18	16	1.5	1.5	78.4	69.2	10.3	5 000	6 700	30208JR	3DB	17	48.5	49	71.5	69	75	3	3.5	1.5	1.5	0.37	1.6	0.88	0.434
45	85	20.75	19	16	1.5	1.5	83.9	77.4	11.6	4 600	6 100	30209JR	3DB	18.9	53.5	54	76.5	74	80	3	4.5	1.5	1.5	0.4	1.48	0.81	0.502
50	90	21.75	20	17	1.5	1.5	95.6	91.7	13.8	4 300	5 700	30210JR	3DB	20.1	58.5	58	81.5	79	85	3	4.5	1.5	1.5	0.42	1.43	0.79	0.566
55	100	22.75	21	18	2	1.5	118	113	17.3	3 900	5 200	30211JR	3DB	20.7	65	64	90	88	94	4	4.5	2	1.5	0.4	1.48	0.81	0.732
60	110	23.75	22	19	2	1.5	133	127	19.7	3 500	4 700	30212JR	3EB	21.9	70	70	100	96	103	4	4.5	2	1.5	0.4	1.48	0.81	0.945
65	140	36	33	28	3	2.5	255	239	37.6	2 800	3 800	30313JR	2GB	29.3	79	83	128	122	130	4	8	2.5	2	0.35	1.74	0.96	2.56
70	125	26.25	24	21	2	1.5	173	173	27.1	3 100	4 100	30214JR	3EB	25.9	80	81	116.5	110	118	4	5	2	1.5	0.42	1.43	0.79	1.32
75	130	27.25	25	22	2	1.5	178	181	28.2	2 900	3 900	30215JR	4DB	27.6	85	86	121.5	115	124	4	5	2	1.5	0.44	1.38	0.76	1.42
80	140	28.25	26	22	2.5	2	202	202	31.2	2 700	3 600	30216JR	3EB	28.6	92	91	130	124	132	4	6	2	2	0.42	1.43	0.79	1.72
85	150	30.5	28	24	2.5	2	228	231	35.1	2 500	3 400	30217JR	3EB	30.4	97	97	140	132	141	5	6.5	2	2	0.42	1.43	0.79	2.17
90	160	32.5	30	26	2.5	2	255	261	39	2 400	3 200	30218JR	3FB	32.6	102	103	150	140	150	5	6.5	2	2	0.42	1.43	0.79	2.65
95	170	34.5	32	27	3	2.5	289	299	44	2 200	3 000	30219JR	3FB	34.9	109	110	158	149	159	5	7.5	2.5	2	0.42	1.43	0.79	3.2
100	180	37	34	29	3	2.5	323	338	49.1	2 100	2 800	30220JR	3FB	36.8	114	116	168	157	168	5	8	2.5	2	0.42	1.43	0.79	3.83
105	190	39	36	30	3	2.5	360	380	52.3	2 000	2 600	30221JR	3FB	39	119	122	178	165	178	6	9	2.5	2	0.42	1.43	0.79	4.49
110	200	41	38	32	3	2.5	405	434	58.1	1 900	2 500	30222JR	3FB	40.08	124	129	188	174	188	6	9	2.5	2	0.42	1.43	0.79	5.33
120	215	43.5	40	34	3	2.5	435	473	61.7	1 700	2 300	30224JR	4FB	44.2	134	140	203	187	203	6	9.5	2.5	2	0.44	1.38	0.76	6.36
140	250	45.75	42	36	4	3	526	570	71.8	1 500	1 900	30228JR	4FB	49.4	158	163	236	219	237	9	9.5	3	2.5	0.44	1.38	0.76	8.97

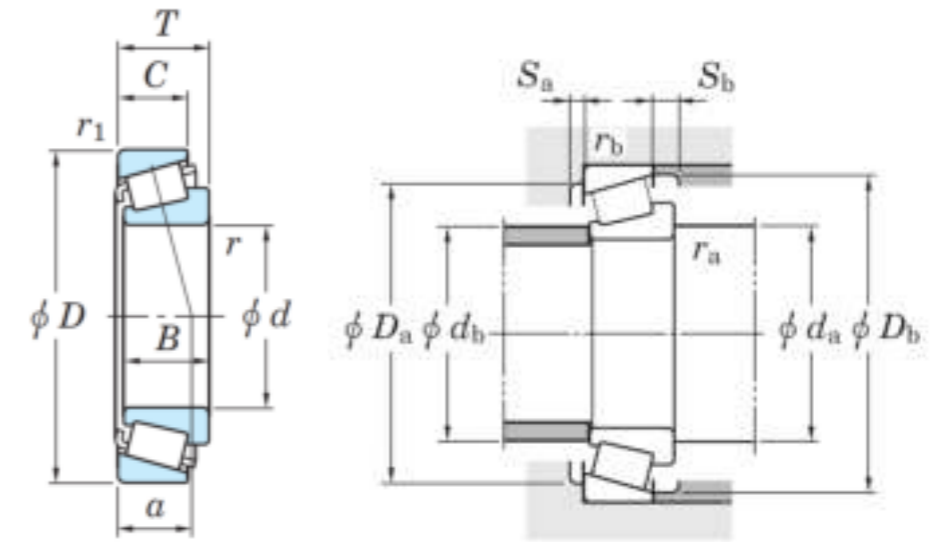
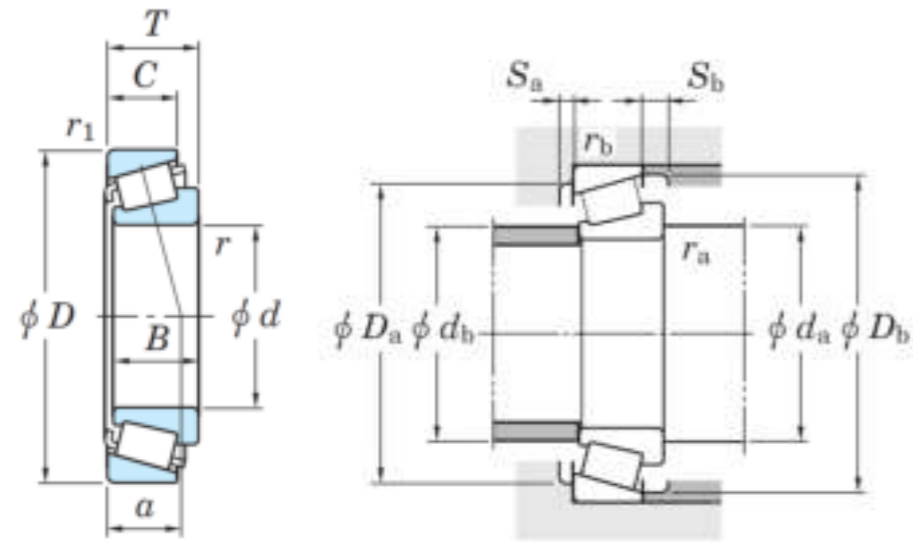

Boundary dimensions(mm)							Basic load ratings(kN)		Fatigue load limit(kN)	Limiting speeds(min-1)		Bearing No.	Dimension series to ISO355	Load center	Mounting dimensions (mm)								Constant e	Axial load factors		Mass (kg)	
d	D	T	B	C	r min.	r1 min.	Cr	Cor	Cu	Grease lub.	Oil lub.				da	db	Da		Db	Sa	Sb	ra		rb	Y1		Y0
															min	max	max	min	min	min	min	max		max			
15	42	14.25	13	11	1	1	27.4	19.2	2.65	10 000	14 000	30302JR	2FB	10	20.5	22	36.5	35	38	2	3	1	1	0.29	2.11	1.16	0.098
17	47	15.25	14	12	1	1	34.2	24.5	3.45	9 200	12 000	30303JR	2FB	11	22.5	25	41.5	40	42	2	3	1	1	0.29	2.11	1.16	0.133
20	52	16.25	16	13	1.5	1.5	45.3	35.1	5.05	8 300	11 000	30304AJR	-	11.1	28.5	28	44	44	47	2	3	1.5	1.5	0.3	2	1.1	0.179
25	62	18.25	17	15	1.5	1.5	60.3	46.9	6.9	6 800	9 000	30305JR	2FB	12.9	33.5	34	54	54	57	2	3	1.5	1.5	0.3	2	1.1	0.273
25	62	18.25	17	13	1.5	1.5	49.7	42.5	5.80	5 700	8 000	30305DJR	-	20.4	33.5	34	-	-	58.5	3	5	1.5	1.5	0.83	0.73	0.40	0.29
30	72	20.75	19	16	1.5	1.5	74.4	60.1	9	5 800	7 700	30306JR	2FB	15.7	38.5	40	63.5	62	66	3	4.5	1.5	1.5	0.31	1.9	1.05	0.411
30	72	20.75	19	16	1.5	1.5	74.4	60.1	9.00	5 800	7 700	30306DJR	-	15.7	38.5	40	-	-	66	3	4.5	1.5	1.5	0.31	1.90	1.05	0.411
35	80	22.75	21	18	2	1.5	76.2	57.2	6.9	5 200	6 900	30307JR	2FB	-	-	-	-	-	-	-	-	-	-	0.31	1.90	1.05	0.527
35	80	22.75	21	15	2	1.5	78.7	69.1	9.85	4 300	6 000	30307DJR	7FB	26.8	45	44	70	66	76.5	3	7.5	2	1.5	0.83	0.73	0.4	0.536
40	90	25.25	23	20	2	1.5	113	101	15.5	4 500	6 100	30308JR	2FB	19.9	50	52	80	77	82	3	5	2	1.5	0.35	1.74	0.96	0.757
40	90	25.25	23	17	2	1.5	100	90.2	13.1	3 800	5 300	30308DJR	-	29.9	50	51	-	-	86.5	3	8	2	1.5	0.83	0.73	0.40	0.757
45	100	27.25	25	22	2	1.5	141	128	19.9	4 100	5 400	30309JR	2FB	21.3	55	59	90	86	93	3	5	2	1.5	0.35	1.74	0.96	1.01
45	100	27.25	25	18	2	1.5	119	107	15.8	3 400	4 700	30309DJR	-	32.9	55	56	-	-	96	3	9	2	1.5	0.83	0.73	0.4	0.973
50	110	29.25	27	23	2.5	2	172	152	24	3 700	4 900	30310JR	2FB	22.9	62	65	98	95	102	3	6	2	2	0.35	1.74	0.96	1.32
50	110	29.25	27	23	2.5	2	172	152	24	3 700	4 900	30310DJR	-	22.9	62	65	-	-	102	3	6	2	2	0.35	1.74	0.96	1.32
55	120	31.5	29	25	2.5	2	187	170	27.0	3 300	4 500	30311JR	-	25.5	67	71	-	-	111	4	6.5	2	2	0.35	1.74	0.96	1.65
55	120	31.5	29	21	2.5	2	161	148	22.3	2 900	4 000	30311DJR	7FB	38.4	67	68	108	94	113	4	10.5	2	2	0.83	0.73	0.4	1.59
60	130	33.5	31	26	3	2.5	217	201	31.9	3 100	4 100	30312JR	-	26.9	74	77	-	-	120	4	7.5	2.5	2	0.35	1.74	0.96	2.08
60	130	33.5	31	22	3	2.5	191	179	27.1	2 600	3 700	30312DJR	7FB	40.8	74	73	118	103	124	4	11.5	2.5	2	0.83	0.73	0.4	2.01
65	140	36	35	30	3	2.5	288	273	42.2	2 600	3 500	30313JR	-	30.5	84	89	-	-	140	4	8	2.5	2	0.35	1.74	0.96	3.08
65	140	36	33	23	3	2.5	220	209	31.4	2 400	3 400	30313DJR	7GB	44.3	79	79	128	111	133	4	13	2.5	2	0.83	0.73	0.4	2.44
70	150	38	35	30	3	2.5	288	273	42.2	2 600	3 500	30314JR	-	30.5	84	89	-	-	140	4	8	2.5	2	0.35	1.74	0.96	3.08
70	150	38	35	25	3	2.5	246	235	34.9	2 300	3 200	30314DJR	7GB	47.1	84	84	138	118	142	4	13	2.5	2	0.83	0.73	0.4	2.97
75	160	40	37	31	3	2.5	313	298	43.3	2 500	3 300	30315JR	-	31.9	89	95	-	-	149	4	9	2.5	2	0.35	1.73	0.95	3.52
75	160	40	37	26	3	2.5	266	254	34.2	2 100	2 900	30315DJR	7GB	49.9	89	91	148	127	151	6	14	2.5	2	0.83	0.73	0.4	3.45
80	170	42.5	39	33	3	2.5	368	355	49.9	2 300	3 100	30316JR	-	34.8	94	102	-	-	159	4	9.5	2.5	2	0.35	1.74	0.96	4.46
80	170	42.5	39	27	3	2.5	294	282	38.7	2 000	2 800	30316DJR	7GB	53.5	94	97	158	134	159	6	15.5	2.5	2	0.83	0.73	0.4	4.12
85	180	44.5	41	34	4	3	396	384	53.0	2 200	2 900	30317JR	-	-	103	107	-	-	167	5	10.5	3	2.5	0.35	1.74	0.96	5.15
85	180	44.5	41	28	4	3	328	317	42.6	1 900	2 600	30317DJR	7GB	56.3	103	103	166	143	169	6	16.5	3	2.5	0.83	0.73	0.4	4.81
90	190	46.5	43	36	4	3	432	420	57.1	2 100	2 700	30318JR	-	-	108	113	-	-	177	5	10.5	3	2.5	0.35	1.74	0.96	6.04
90	190	46.5	43	30	4	3	359	350	46.2	1 700	2 400	30318DJR	7GB	59.6	108	109	176	151	179	6	16.5	3	2.5	0.83	0.73	0.4	5.57
95	200	49.5	45	38	4	3	465	455	60.9	2 000	2 600	30319JR	-	-	113	118	-	-	183	5	11.5	3	2.5	0.35	1.74	0.96	6.96
95	200	49.5	45	32	4	3	398	391	50.4	1 700	2 300	30319DJR	7GB	62.7	113	113	186	157	187	6	17.5	3	2.5	0.83	0.73	0.4	6.68

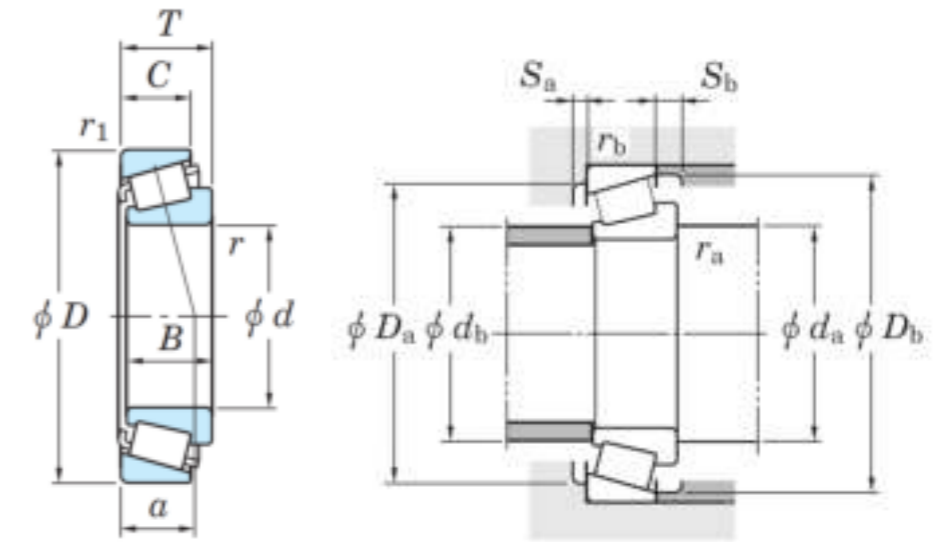
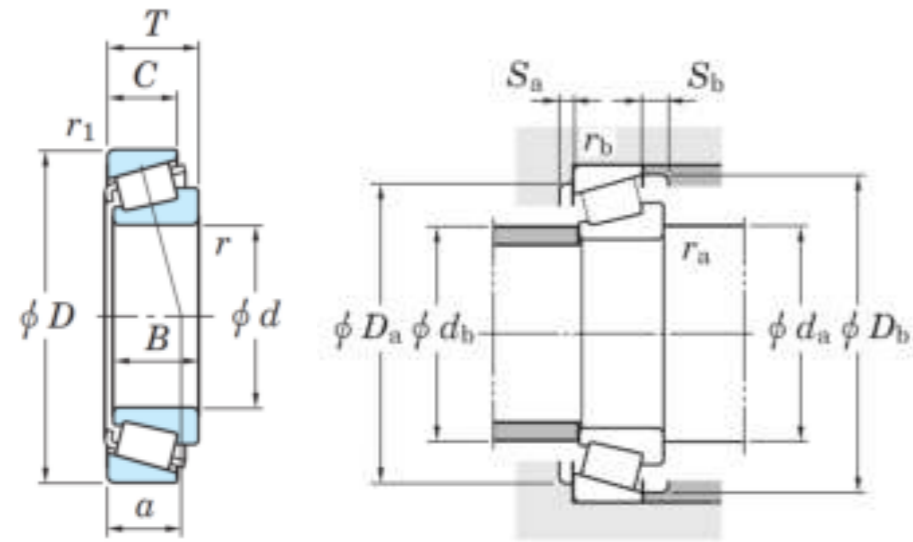

Boundary dimensions(mm)							Basic load ratings(kN)		Fatigue load limit(kN)	Limiting speeds(min-1)		Bearing No.	Dimension series to ISO355	Load center	Mounting dimensions (mm)								Constant e	Axial load factors		Mass (kg)	
d	D	T	B	C	r min.	r1 min.	Cr	Cor	Cu	Grease lub.	Oil lub.				da	db	Da		Db	Sa	Sb	ra		rb	Y1		Y0
															min	max	max	min	min	min	min	max		max			
100	215	51.5	47	39	4	3	528	521	68.0	1 800	2 400	30320JR	-	-	118	127	-	-	200	6	12.5	3	2.5	0.35	1.74	0.96	8.49
100	215	51.5	47	34	4	3	397	374	48.5	1 500	2 100	30320DJR	-	65.9	118	121	201	183	204	5	17	3	2.5	0.81	0.74	0.41	8.02
110	240	54.5	50	42	4	3	601	590	75.2	1 600	2 100	30322JR	-	46.3	128	141	-	-	222	8	12.5	3	2.5	0.36	1.74	0.96	11.4
110	240	54.5	50	36	4	3	456	429	53.5	1 400	1 900	30322DJR	-	71.5	128	135	226	205	222	6	18	3	2.5	0.81	0.74	0.41	10.2
120	260	59.5	55	46	4	3	712	714	89.9	1 500	2 000	30324JR	2GB	50.2	138	152	246	221	239	10	13.5	3	2.5	0.35	1.74	0.96	14.5
130	280	63.75	58	49	5	4	823	834	102	1 400	1 800	30326JR	2GB	54.0	152	164	262	239	255	8	14.5	4	3	0.35	1.74	0.96	18.1
130	280	63.75	58	41	5	4	604	582	69.9	1 200	1 600	30326DJR	-	84.0	152	155	262	240	261	7	22	4	3	0.81	0.74	0.41	16.3
140	300	67.75	62	53	5	4	938	962	114	1 300	1 700	30328JR	2GB	56.9	162	179	282	254	273	10	14.5	4	3	0.35	1.74	0.96	22.6

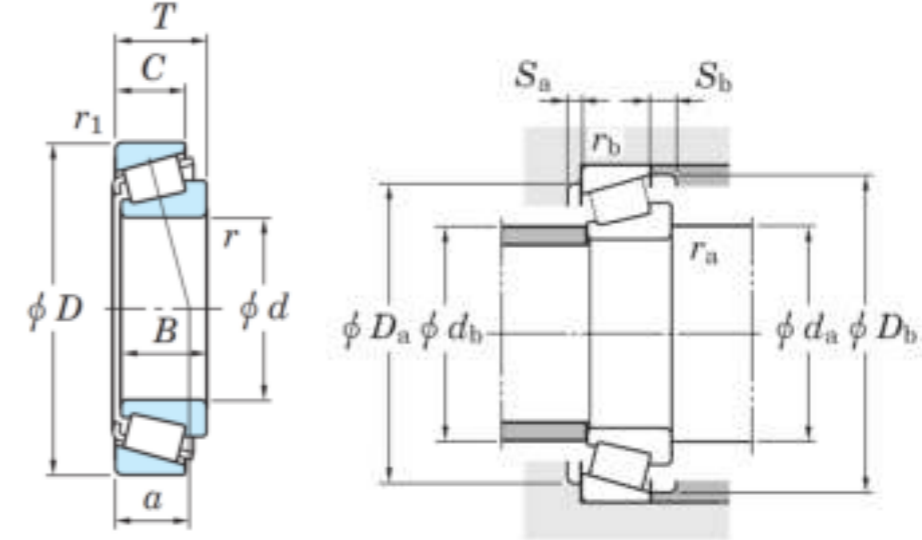
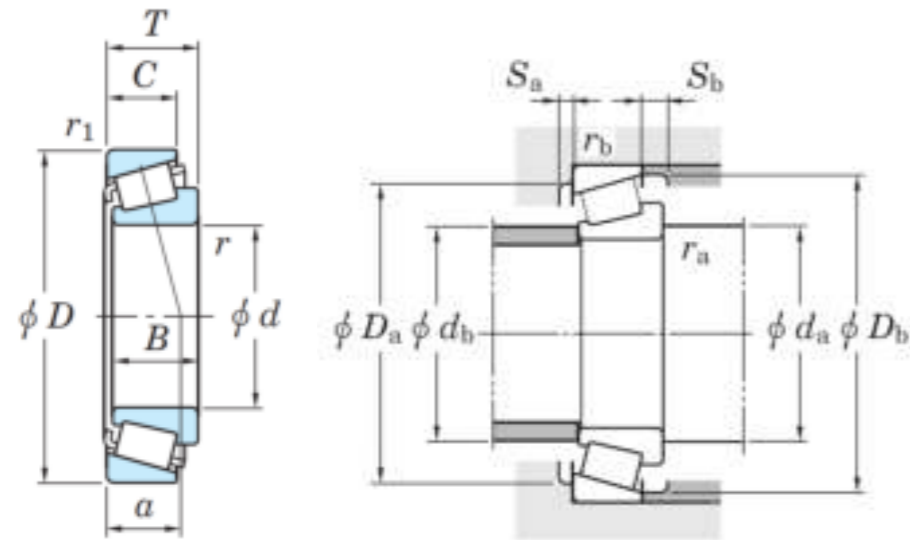

Boundary dimensions(mm)							Basic load ratings(kN)		Fatigue load limit(kN)	Limiting speeds(min-1)		Bearing No.	Dimension series to ISO355	Load center	Mounting dimensions (mm)								Constant e	Axial load factors		Mass (kg)		
d	D	T	B	C	r min.	r1 min.	Cr	Cor	Cu	Grease lub.	Oil lub.				da	db	Da		Db	Sa	Sb	ra		rb	Y1		Y0	
															min	max	max	min	min	min	min	max		max				
20	42	15	15	12	0.6	0.6	34.1	31.5	4.35	9 700	13 000	32004JR	3CC	10.5	24.5	25	37.5	35	39	3	3	0.6	0.6	0.37	1.6	0.88	0.102	
25	47	15	15	11.5	0.6	0.6	37.8	37.7	5.2	8 300	11 000	32005JR	4CC	11.8	29.5	30	42.5	40	44	3	3.5	0.6	0.6	0.43	1.39	0.77	0.118	
25	47	15	-	-	-	-	-	-	-	-	-	32005JR RS	-	-	-	-	-	-	-	-	-	-	-	-	-	-	-	
28	52	16	16	12	1	1	44.1	44.0	6.10	7 500	10 000	32028JR	-	12.7	33.5	33	-	-	49	3	4	1	1	0.43	1.39	0.77	0.150	
30	55	17	17	13	1	1	47.9	48	6.75	7 000	9 400	32006JR	4CC	13.6	35.5	35	49.5	47	52	3	4	1	1	0.43	1.39	0.77	0.177	
30	55	17	-	-	-	-	-	-	-	-	-	32006JR RS	-	-	-	-	-	-	-	-	-	-	-	-	-	-	-	
35	62	18	18	14	1	1	57	59.4	8.4	6 200	8 200	32007JR	4CC	15.1	40.5	40	56.5	54	59	4	4	1	1	0.45	1.32	0.73	0.231	
40	68	19	19	14.5	1	1	67.2	71.4	10.3	5 600	7 400	32008JR	3CD	15.1	45.5	46	62.5	60	65	4	4.5	1	1	0.38	1.58	0.87	0.282	
45	75	20	20	15.5	1	1	78.8	86.5	12.6	5 000	6 600	32009JR	3CC	16.5	50.5	51	69.5	67	72	4	4.5	1	1	0.39	1.53	0.84	0.354	
50	80	20	20	15.5	1	1	82.7	94.5	13.8	4 600	6 100	32010JR	3CC	17.7	55.5	56	74.5	72	77	4	4.5	1	1	0.42	1.42	0.78	0.389	
55	90	23	23	17.5	1.5	1.5	106	121	18.2	4 100	5 500	32011JR	3CC	19.8	63.5	63	81.5	81	86	4	5.5	1.5	1.5	0.41	1.48	0.81	0.569	
60	95	23	23	17.5	1.5	1.5	108	127	19	3 900	5 200	32012JR	4CC	21	68.5	67	86.5	85	91	4	5.5	1.5	1.5	0.43	1.39	0.77	0.621	
65	110	23	23	17.5	1.5	1.5	113	117	20.6	3 600	4 800	32013JR	3DE	22.5	73.5	72	-	-	97	4	5.5	1.5	1.5	0.46	1.31	0.72	0.664	
70	110	25	25	19	1.5	1.5	136	163	24.8	3 300	4 400	32014JR	4CC	23.6	78.5	78	101.5	98	105	5	6	1.5	1.5	0.43	1.38	0.76	0.884	
75	115	25	25	19	1.5	1.5	139	169	25.8	3 100	4 200	32015JR	4CC	25.1	83.5	83	106.5	103	110	5	6	1.5	1.5	0.46	1.31	0.72	0.930	
80	125	29	29	22	1.5	1.5	185	225	34.6	2 900	3 900	32016JR	3CC	26.7	88.5	89	116.5	112	120	6	7	1.5	1.5	0.42	1.42	0.78	1.32	
85	130	29	29	22	1.5	1.5	189	234	35.5	2 800	3 700	32017JR	4CC	28	93.5	94	121.5	117	125	6	7	1.5	1.5	0.44	1.36	0.75	1.38	
90	140	32	32	24	2	1.5	224	276	41.5	2 600	3 500	32018JR	3CC	29.8	100	100	131.5	125	134	6	8	2	1.5	0.42	1.42	0.78	1.8	
95	145	32	32	24	2	1.5	229	287	42.6	2 500	3 300	32019JR	4CC	31.2	105	105	136.5	130	140	6	8	2	1.5	0.44	1.36	0.75	1.88	
100	150	32	32	24	2	1.5	233	298	43.8	2 400	3 200	32020JR	4CC	32.6	110	109	141	134	144	6	8	2	1.5	0.46	1.31	0.72	1.95	
110	170	38	38	29	2.5	2	312	395	56.7	2 100	2 800	32022JR	4DC	36.1	122	122	160	152	163	7	9	2	2	0.43	1.39	0.77	3.12	
120	180	38	38	29	2.5	2	325	427	60	2 000	2 600	32024JR	4DC	38.8	132	131	170	161	173	7	9	2	2	0.46	1.31	0.72	3.34	
130	200	45	45	34	2.5	2	428	563	77.4	1 800	2 300	32026JR	4EC	42.9	142	144	190	178	192	8	11	2	2	0.43	1.38	0.76	5.04	
140	210	45	45	34	2.5	2	435	585	79.2	1 700	2 200	32028JR	4DC	45.6	152	153	200	187	202	8	11	2	2	0.46	1.31	0.72	5.28	
150	225	48	48	36	3	2.5	492	668	79.6	1 500	2 000	32030JR	-	48.8	164	164	-	213	200	216	8	2.5	2	2	0.46	1.31	0.72	6.41

RS = Sealed

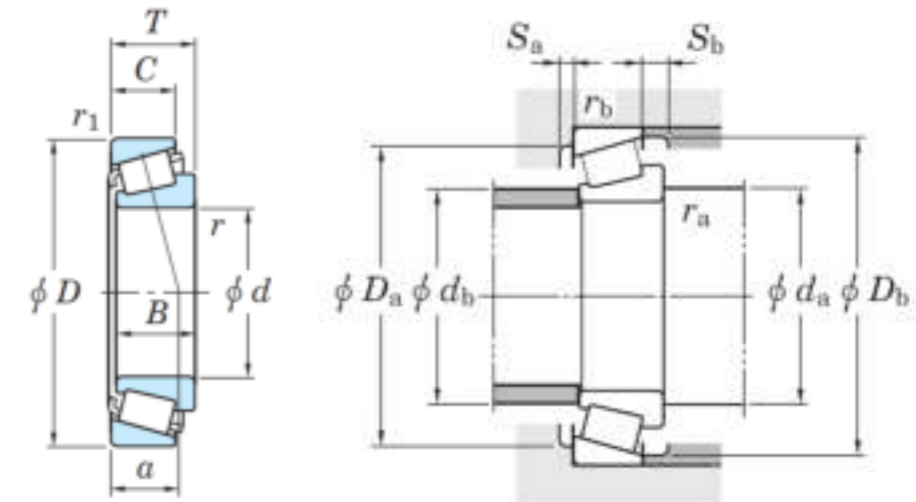
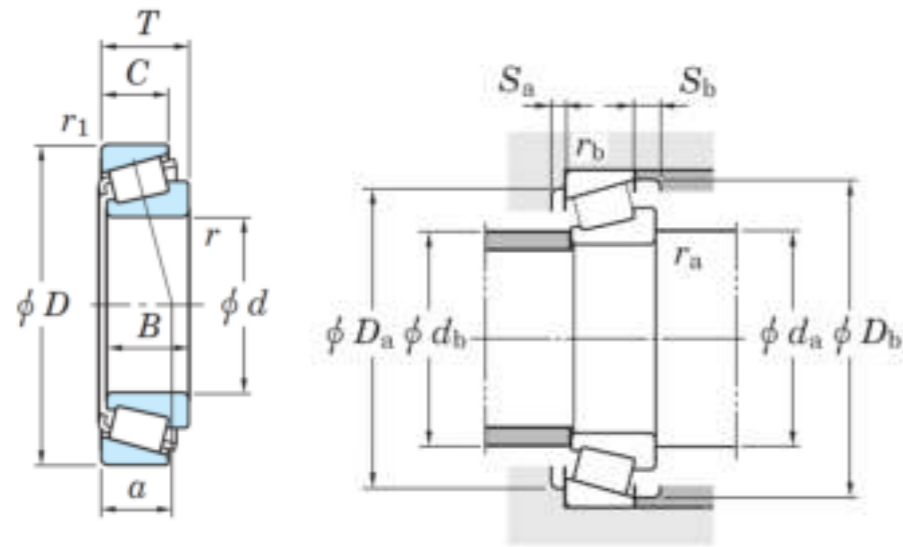

Boundary dimensions(mm)							Basic load ratings(kN)		Fatigue load limit(kN)	Limiting speeds(min-1)		Bearing No.	Dimension series to ISO355	Load center	Mounting dimensions (mm)								Constant e	Axial load factors		Mass (kg)	
d	D	T	B	C	r min.	r1 min.	Cr	Cor	Cu	Grease lub.	Oil lub.				da	db	Da		Db	Sa	Sb	ra		rb	Y1		Y0
											min	max	max	min	min	min	min	max	max								
17	40	17.25	16	14	1	1	34.3	27.5	3.85	10000	14000	32203JR	2DD	11.4	22.5	23	34.5	33	37	2	3	1	1	0.31	1.92	1.06	0.104
20	47	19.25	18	15	1	1	41.4	34.7	4.9	8900	12000	32204JR	2DD	12.5	25.5	27	41.5	39	43	2	4	1	1	0.33	1.81	1	0.159
25	52	19.25	18	16	1	1	49.7	44.8	6.35	7900	11000	32205JR	2CD	13.5	30.5	31	46.5	43	48	2	4	1	1	0.36	1.67	0.92	0.188
30	62	21.25	20	17	1	1	63.3	57.9	8.4	6500	8700	32206JR	3DC	15.9	35.5	37	56.5	52	58	2	4	1	1	0.37	1.6	0.88	0.292
35	72	24.25	23	19	1.5	1.5	86.9	82.4	12.2	5600	7500	32207JR	3DC	18.2	43.5	43	63.5	61	67	3	5	1.5	1.5	0.37	1.6	0.88	0.453
40	80	24.75	23	19	1.5	1.5	97	90.8	13.6	5000	6600	32208JR	3DC	19.4	48.5	48	71.5	68	75	3	5.5	1.5	1.5	0.37	1.6	0.88	0.554
45	85	24.75	23	19	1.5	1.5	105	104	15.6	4600	6100	32209JR	3DC	20.3	53.5	53	76.5	73	81	3	5.5	1.5	1.5	0.4	1.48	0.81	0.597
50	90	24.75	23	19	1.5	1.5	106	105	15.9	4300	5700	32210JR	3DC	20.6	58.5	58	81.5	78	85	3	5.5	1.5	1.5	0.42	1.43	0.79	0.643
55	100	26.75	25	21	2	1.5	134	133	20.5	3900	5200	32211JR	3DC	23	65	63	90	87	95	4	5.5	2	1.5	0.4	1.48	0.81	0.863
60	110	29.75	28	24	2	1.5	164	167	25.9	3500	4700	32212JR	3EC	25.1	70	69	100	95	104	4	5.5	2	1.5	0.4	1.48	0.81	1.19
65	120	32.75	31	27	2	1.5	196	203	31.7	3200	4300	32213JR	3EC	26.6	75	76	110	104	115	4	5.5	2	1.5	0.4	1.48	0.81	1.58
70	125	33.25	31	27	2	1.5	212	225	35.2	3100	4100	32214JR	3EC	29.2	80	80	116.5	108	119	4	6	2	1.5	0.42	1.43	0.79	1.71
75	130	33.25	31	27	2	1.5	218	234	36.4	2900	3900	32215JR	4DC	30.2	85	85	121.5	114	125	4	6	2	1.5	0.44	1.38	0.76	1.77
80	140	35.25	33	28	2.5	2	253	271	41.5	2700	3600	32216JR	3EC	31.7	92	90	130	122	134	4	7	2	2	0.42	1.43	0.79	2.17
85	150	38.5	36	30	2.5	2	290	315	47.5	2500	3400	32217JR	3EC	34.2	97	96	140	130	142	5	8.5	2	2	0.42	1.43	0.79	2.8
90	160	42.5	40	34	2.5	2	329	362	53.7	2400	3200	32218JR	3FC	37	102	102	150	138	152	5	8.5	2	2	0.42	1.43	0.79	3.47
95	170	45.5	43	37	3	2.5	389	439	64.1	2200	3000	32219JR	3FC	38.9	109	108	158	145	161	5	8.5	2.5	2	0.42	1.43	0.79	4.34
100	180	49	46	39	3	2.5	435	495	63.9	2100	2800	32220JR	3FC	42.1	114	114	168	154	171	5	10	2.5	2	0.42	1.43	0.79	5.21
105	190	53	50	43	3	2.5	490	567	73	2000	2700	32221JR	3FC	44.8	119	120	178	161	180	6	10	2.5	2	0.42	1.43	0.79	6.37
110	200	56	53	46	3	2.5	547	640	80.4	1900	2500	32222JR	3FC	46.7	124	126	188	170	190	6	10	2.5	2	0.42	1.43	0.79	7.45
120	215	61.5	58	50	3	2.5	589	691	84	1700	2300	32224JR	4FD	51.6	134	136	203	181	204	7	11.5	2.5	2	0.44	1.38	0.76	9.04
130	230	67.75	64	54	4	3	693	830	99.9	1600	2200	32226JR	4FD	56.0	148	146	216	193	219	7	13.5	3	2.5	0.44	1.38	0.76	11.5
140	250	71.75	68	58	4	3	796	961	112	1500	2000	32228JR	4FD	60.0	158	158	236	210	238	9	13.5	3	2.5	0.44	1.38	0.76	14.7
150	270	77	73	60	4	3	881	1070	122	1300	1800	32230JR	4GD	65.2	168	170	256	226	254	8	17	3	2.5	0.44	1.38	0.76	18.2

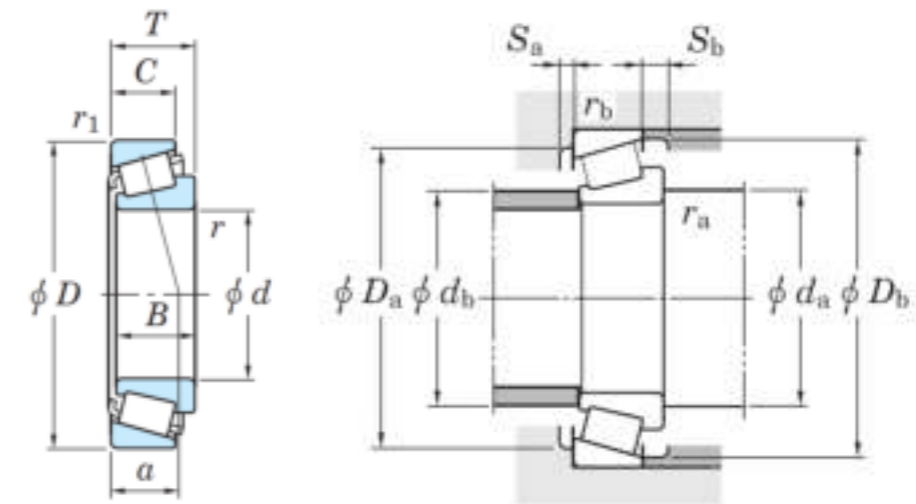
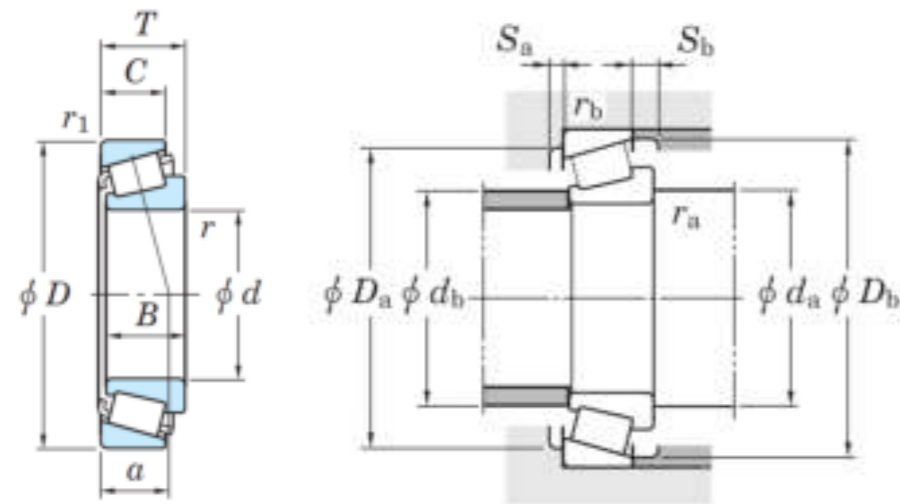

Boundary dimensions(mm)							Basic load ratings(kN)		Fatigue load limit(kN)	Limiting speeds(min-1)		Bearing No.	Dimension series to ISO355	Load center	Mounting dimensions								Constant	Axial load factors		Mass	
d	D	T	B	C	r min.	r1 min.	Cr	Cor	Cu	Grease lub.	Oil lub.				da	db	Da		Db	Sa	Sb	ra		rb	Y1		Y0
															min	max	max	min	min	min	min	max		max			
17	47	20.25	19	16	1	1	39.9	29.9	4.25	9 400	13 000	32303JR	2FD	12.4	22.5	25	41.5	39	43	2	4	1	1	0.28	2.11	1.16	0.170
20	52	22.25	21	18	1.5	1.5	56.5	46.7	6.70	8400	11000	32304JR	2FD	14.4	28.5	27	43.5	43	47	3	4	1.5	1.5	0.30	2.00	1.10	0.244
25	62	25.25	24	20	1.5	1.5	76.6	64.1	9.5	6 900	9 100	32305JR	2FD	16.6	33.5	33	53.5	52	57	3	5	1.5	1.5	0.3	2	1.1	0.386
30	72	28.75	27	23	1.5	1.5	103	91.6	13.8	5 900	7 900	32306JR	2FD	18.9	38.5	39	63.5	59	66	3	5.5	1.5	1.5	0.31	1.9	1.05	0.588
35	80	32.75	31	25	2	1.5	126	114	17.3	5 300	7 000	32307JR	2FE	20.6	45	44	70	66	74	3	7.5	2	1.5	0.31	1.9	1.05	0.776
40	90	35.25	33	27	2	1.5	145	139	21.3	4 600	6 200	32308JR	2FD	24.3	50	50	80	73	82	3	8	2	1.5	0.35	1.74	0.96	1.06
45	100	38.25	36	30	2	1.5	183	180	27.7	4 100	5 500	32309JR	2FD	26.8	55	56	90	82	93	3	8	2	1.5	0.35	1.74	0.96	1.43
50	110	42.25	40	33	2.5	2	221	220	34.2	3 700	5 000	32310JR	2FD	29.4	62	62	98	90	102	3	9	2	2	0.35	1.74	0.96	1.89
55	120	45.5	43	35	2.5	2	250	250	39.1	3 400	4 500	32311JR	2FD	32.4	67	68	108	99	111	4	10.5	2	2	0.35	1.74	0.96	2.38
60	130	48.5	46	37	3	2.5	277	275	38.6	3 100	4 200	32312JR	2FD	32.3	74	74	118	107	120	4	11.5	2.5	2	0.35	1.74	0.96	2.87
65	140	51	48	39	3	2.5	346	357	49.6	2 900	3 900	32313JR	2GD	34.7	79	80	128	117	130	4	12	2.5	2	0.35	1.74	0.96	3.64
70	150	54	51	42	3	2.5	396	414	57.2	2 700	3 600	32314JR	2GD	37.4	84	86	138	125	140	4	12	2.5	2	0.35	1.74	0.96	4.5
75	160	58	55	45	3	2.5	454	481	64.6	2 500	3 300	32315JR	2GD	40	89	91	148	133	149	4	13	2.5	2	0.35	1.74	0.96	5.41
80	170	61.5	58	48	3	2.5	480	503	67.0	2300	3100	32316JR	2GD	43.5	94	98	158	142	159	4	13.5	2.5	2	0.35	1.74	0.96	6.31
85	180	63.5	60	49	4	3	549	587	77.6	2200	3000	32317JR	2GD	43.8	103	103	166	150	167	5	14.5	3	2.5	0.35	1.74	0.96	7.42
90	190	67.5	64	53	4	3	577	614	78.7	2100	2800	32318JR	2GD	46.6	108	108	176	157	177	5	14.5	3	2.5	0.35	1.74	0.96	8.61
95	200	71.5	67	55	4	3	646	695	89.2	2000	2600	32319JR	2GB	49.8	113	115	186	166	186	5	16.5	3	2.5	0.35	1.74	0.96	10.1
100	215	77.5	73	60	4	3	725	783	96.9	1800	2400	32320JR	2GD	53.9	118	123	201	177	200	8	17.5	3	2.5	0.35	1.74	0.96	13.0

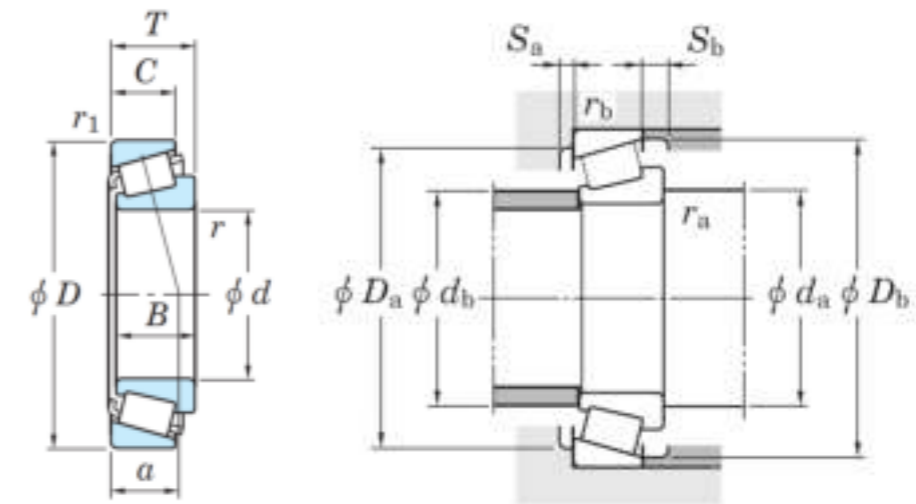
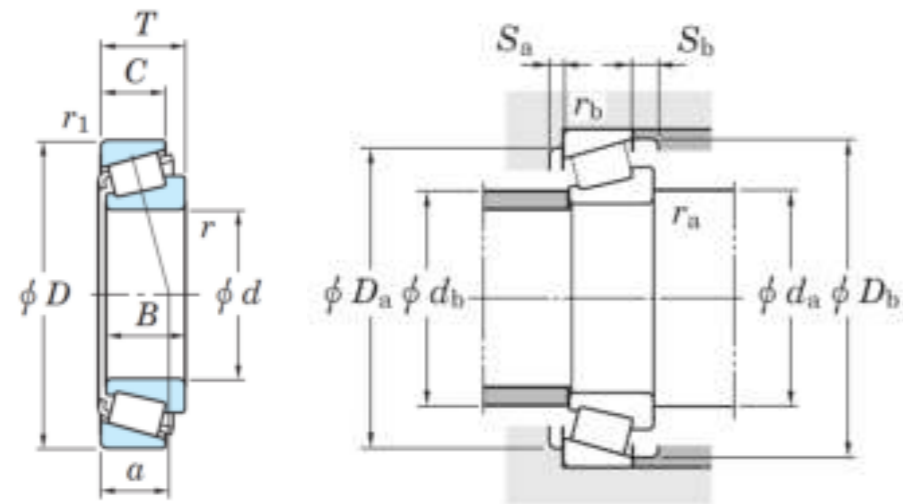

Boundary dimensions(mm)							Basic load ratings(kN)		Fatigue load limit(kN)	Limiting speeds(min-1)		Bearing No.	Dimension series to ISO355	Load center	Mounting dimensions								Constant	Axial load factors		Mass	
d	D	T	B	C	r min.	r1 min.	Cr	Cor	Cu	Grease lub.	Oil lub.				da	db	Da		Db	Sa	Sb	ra		rb			
															min	max	max	min	min	min	min	max		max			
35	55	14	14	11.5	0.6	0.6	32.8	36.5	5.1	6 600	8 800	32907JR-2	2BD	10.9	39.5	40	50.5	49	52	2.5	2.5	0.6	0.6	0.29	2.06	1.13	0.12
35	55	14	14	11.5	0.6	0.6	32.8	36.5	5.10	6 600	8 800	32907JR-3	2BD	10.9	39.5	40	50.5	49	52	2.5	2.5	0.6	0.6	0.29	2.06	1.13	0.120
40	62	15	15	12	0.6	0.6	42.1	48.5	6.90	5 900	7 800	32908JR	2BC	11.9	44.5	45	57.5	55	59	3	3	0.6	0.6	0.29	2.07	1.14	0.164
45	68	15	15	12	0.6	0.6	43.5	52.4	7.45	5 300	7 100	32909JR	2BC	12.5	49.5	50	63.5	61	64	3	3	0.6	0.6	0.32	1.88	1.04	0.190
50	72	15	15	12	0.6	0.6	45	56.3	8.00	4 900	6 600	32910JR	2BC	13.7	54.5	55	67.5	65	69	3	3	0.6	0.6	0.34	1.76	0.97	0.195
55	80	17	17	14	1	1	55.8	73.3	10.60	4 400	5 900	32911JR	2BC	14.5	61	61	74	72	76	3	3	1	1	0.31	1.94	1.07	0.285
60	85	17	17	14	1	1	57.6	78.2	11.30	4 100	5 500	32912JR	2BC	15.6	65.5	66	79.5	77	81	3	3	1	1	0.33	1.81	1	0.306
65	90	17	17	14	1	1	59.2	83.1	12	3 900	5 200	32913JR	2BC	16.8	70.5	70	84.5	81	86	3	3	1	1	0.35	1.7	0.93	0.327
70	100	20	20	16	1	1	89	115	17.2	3 500	4 700	32914JR	2BC	17.8	75.5	77	94.5	91	96	4	4	1	1	0.32	1.9	1.05	0.496
75	105	20	20	16	1	1	92.2	123	18.4	3 000	4 400	32915JR	2BC	18.9	80.5	81	99.5	96	101	4	4	1	1	0.33	1.8	0.99	0.526

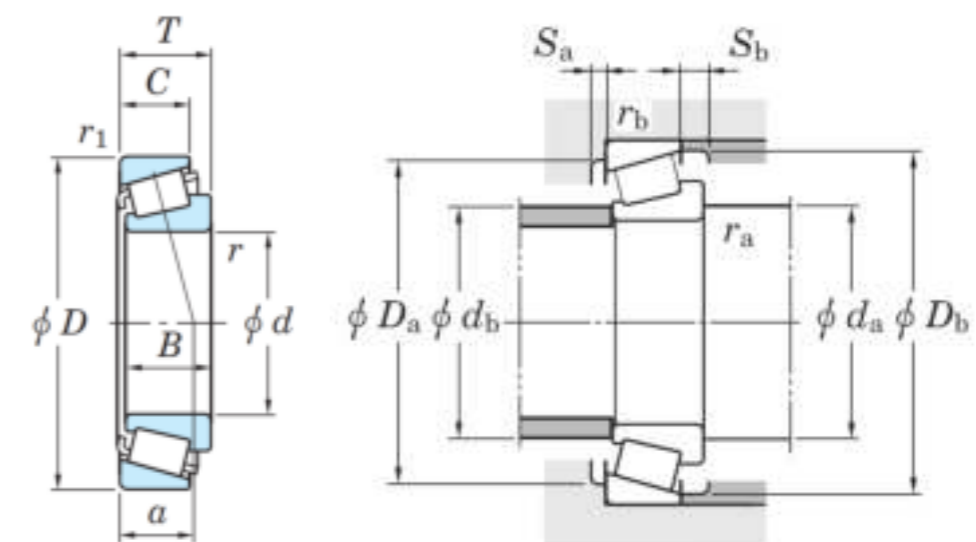
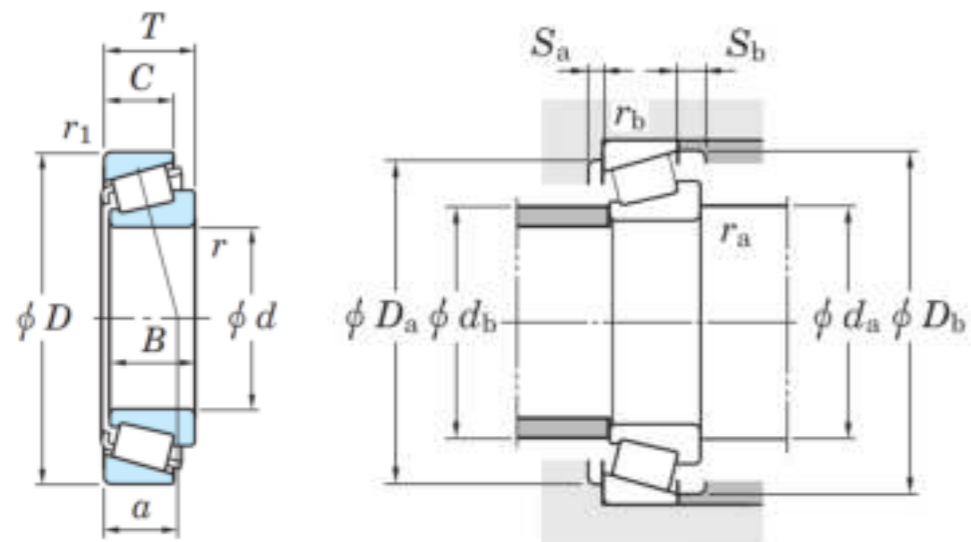

Boundary dimensions(mm)							Basic load ratings(kN)		Fatigue load limit(kN)	Limiting speeds(min-1)		Bearing No.	Dimension series to ISO355	Load center	Mounting dimensions (mm)								Constant e	Axial load factors		Mass (kg)							
d	D	T	B	C	r min.	r1 min.	Cr	Cor	Cu	Grease lub.	Oil lub.				da	db	Da	Db	Sa	Sb	ra	rb		Y1	Y0								
																					min	max	max	min	min	min	min	max	max				
25	47	17	17	14	0.6	0.6	42	42.3	5.95	8300	11000	33005JR	2CE	10.9	29.5	30	42.5	41	44	3	3	0.6	0.6	0.29	2.07	1.14	0.131						
30	55	20	20	16	1	1	54.1	55.2	7.90	7000	9400	33006JR	2CE	13.0	35.5	36	49.5	48	52	3	4	1	1	0.29	2.06	1.13	0.203						
35	62	21	21	17	1	1	64.3	68	9.85	6200	8200	33007JR	2CE	14.2	40.5	41	56.5	55	59	3	4	1	1	0.31	1.97	1.08	0.263						
40	68	22	22	18	1	1	75.9	84.6	12.4	5500	7400	33008JR	2BE	14.7	45.5	46	62.5	60	65	3	4	1	1	0.28	2.12	1.17	0.326						
45	75	24	24	19	1	1	87.4	101	14.9	5000	6700	33009JR	2CE	16.4	50.5	51	69.5	67	71	4	5	1	1	0.29	2.04	1.12	0.416						
50	80	24	24	19	1	1	91.8	110	16.3	4600	6100	33010JR	2CE	17.4	55.5	56	74.5	72	76	4	5	1	1	0.32	1.90	1.04	0.451						
55	90	27	27	21	1.5	1.5	121	149	22.6	4100	5400	33011JR	2CE	19.3	63.5	63	81.5	81	86	5	6	1.5	1.5	0.31	1.92	1.06	0.672						
60	95	27	27	21	1.5	1.5	127	162	24.5	3900	5200	33012JR	2CE	20.1	68.5	67	86.5	85	90	5	6	1.5	1.5	0.33	1.83	1.01	0.719						
65	100	27	27	21	1.5	1.5	129	169	25.5	3600	4800	33013JR	2CE	21.1	73.5	72	91.5	89	96	5	6	1.5	1.5	0.35	1.72	0.95	0.762						
70	110	31	31	25.5	1.5	1.5	168	208	32.3	3300	4400	33014JR	2CE	22.1	78.5	78	101.5	99	105	5	5.5	1.5	1.5	0.28	2.11	1.16	1.09						
75	115	31	31	25.5	1.5	1.5	177	225	35.0	3200	4200	33015JR	2CE	22.9	83.5	83	106.5	104	110	6	5.5	1.5	1.5	0.30	2.01	1.11	1.16						
80	125	36	36	29.5	1.5	1.5	218	288	44.8	2900	3900	33016JR	2CE	25.1	88.5	90	116.5	112	119	6	6.5	1.5	1.5	0.28	2.16	1.19	1.63						
85	130	36	36	29.5	1.5	1.5	222	300	46.0	2800	3700	33017JR	2CE	26.3	93.5	94	121.5	118	125	6	6.5	1.5	1.5	0.29	2.06	1.13	1.72						
90	140	39	39	32.5	2	1.5	278	367	55.6	2600	3400	33018JR	2CE	27.1	100	100	131.5	127	135	7	6.5	2	1.5	0.27	2.23	1.23	2.22						
95	145	39	39	32.5	2	1.5	284	382	57.3	2500	3300	33019JR	2CE	27.8	105	104	136.5	131	139	7	6.5	2	1.5	0.28	2.16	1.19	2.31						
100	150	39	39	32.5	2	1.5	290	397	59.0	2400	3200	33020JR	2CE	28.6	110	108	141	135	143	7	6.5	2	1.5	0.29	2.09	1.15	2.40						
105	160	43	43	34	2.5	2	335	461	67.4	2200	3000	33021JR	2DE	30.9	117	116	150	145	153	7	9	2	2	0.28	2.12	1.17	3.08						
110	170	47	47	37	2.5	2	360	502	64.9	2100	2800	33022JR	2DE	33.4	122	123	160	152	161	7	10	2	2	0.29	2.09	1.15	3.81						
120	180	48	48	38	2.5	2	375	540	68.5	2000	2600	33024JR	2DE	36.2	132	132	170	160	171	6	10	2	2	0.31	1.97	1.08	4.16						
130	200	55	55	43	2.5	2	489	705	85.8	1700	2300	33026JR	2EE	42.5	142	143	190	178	192	8	12	2	2	0.34	1.76	0.97	6.19						
150	225	59	59	46	3	2.5	575	869	101	1500	2000	33030JR	2EF	47.8	164	164	213	200	217	8	13	2.5	2	0.36	1.65	0.9	8.09						

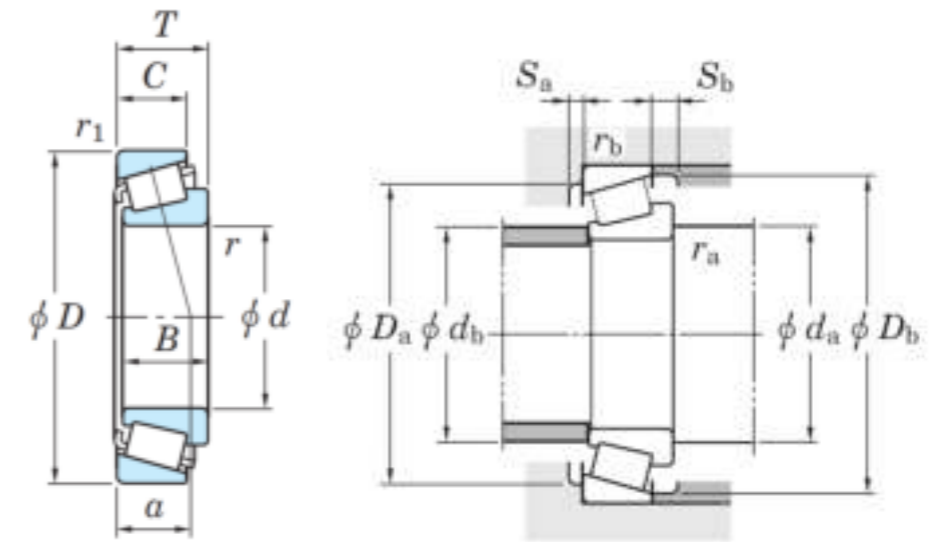
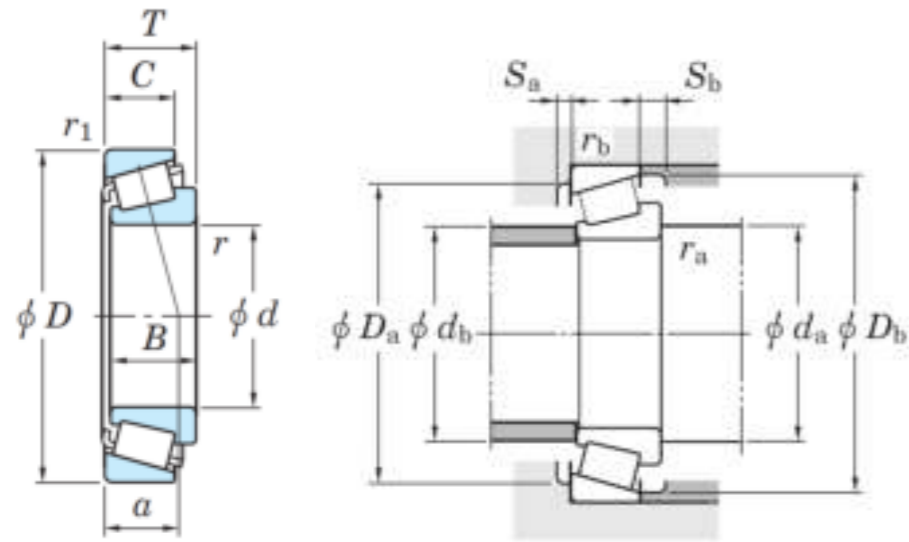

Boundary dimensions(mm)							Basic load ratings(kN)		Fatigue load limit(kN)	Limiting speeds(min-1)		Bearing No.	Dimension series to ISO355	Load center	Mounting dimensions (mm)								Constant e	Axial load factors		Mass (kg)	
d	D	T	B	C	r min.	r1 min.	Cr	Cor	Cu	Grease lub.	Oil lub.				da	db	Da	Db	Sa	Sb	ra	rb		Y1	Y0		
															min	max	max	min	min	min	min	max		max			
40	75	26	26	20.5	1.5	1.5	103	108	16.1	5200	6900	33108JR	2CE	18.3	48.5	47	66.5	65	71	4	5.5	1.5	1.5	0.36	1.69	0.93	0.508
45	80	26	26	20.5	1.5	1.5	110	120	17.9	4800	6400	33109JR	3CE	19.4	53.5	52	71.5	69	76.5	4	5.5	1.5	1.5	0.38	1.57	0.86	0.563
50	85	26	26	20	1.5	1.5	112	127	18.9	4400	5900	33110JR	3CE	20.6	58.5	56	76.5	74	81.5	4	6	1.5	1.5	0.41	1.46	0.80	0.594
55	95	30	30	23	1.5	1.5	145	161	24.6	4000	5300	33111JR	3CE	22.5	63.5	62	86.5	83	91	5	7	1.5	1.5	0.37	1.60	0.88	0.868
60	100	30	30	23	1.5	1.5	149	170	25.9	3700	5000	33112JR	3CE	23.7	68.5	67	91.5	88	96	5	7	1.5	1.5	0.40	1.51	0.83	0.923
65	110	34	34	26.5	1.5	1.5	191	223	34.3	3400	4600	33113JR	3DE	25.9	73.5	73	101.5	96	106	6	7.5	1.5	1.5	0.39	1.55	0.85	1.33
75	125	37	37	29	2	1.5	234	280	43.4	3000	4000	33115JR	3DE	29.3	85	84	116.5	109	120	6	8	2	1.5	0.40	1.51	0.83	1.84
80	130	37	37	29	2	1.5	240	294	44.9	2800	3800	33116JR	3DE	30.5	90	89	121.5	114	126	6	8	2	1.5	0.42	1.44	0.79	1.93
90	150	45	45	35	2.5	2	324	413	61.1	2500	3300	33118JR	3DE	35.4	102	100	140	130	144	7	10	2	2	0.40	1.51	0.83	3.13

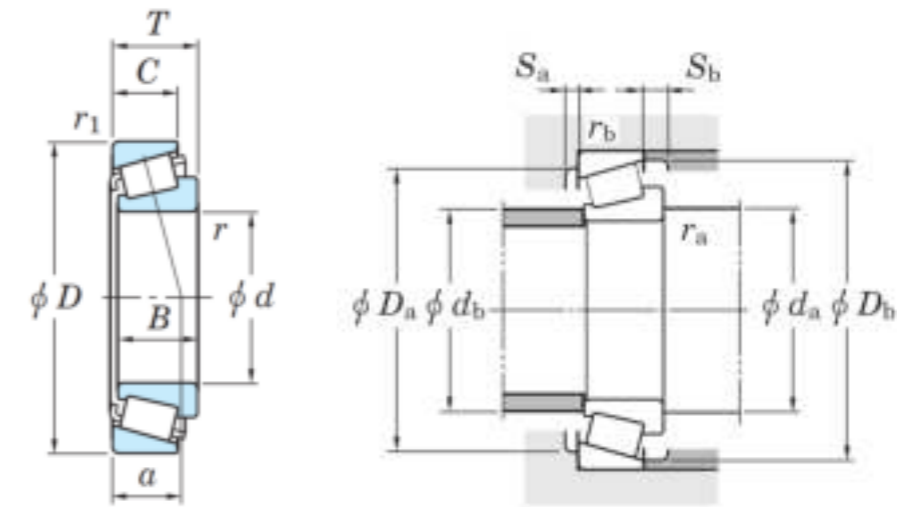
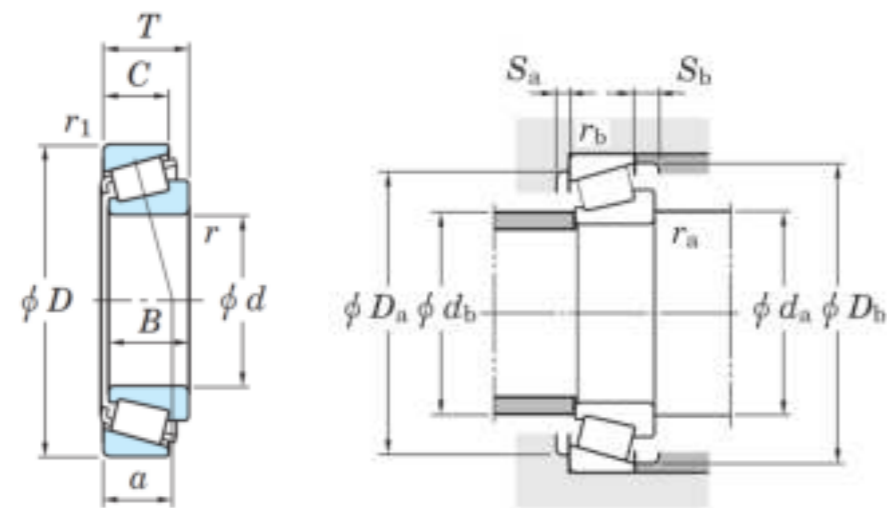

Boundary dimensions(mm)							Basic load ratings(kN)		Fatigue load limit(kN)	Limiting speeds(min-1)		Bearing No.	Dimension series to ISO355	Load center	Mounting dimensions (mm)								Constant e	Axial load factors		Mass (kg)	
d	D	T	B	C	r min.	r1 min.	Cr	Cor	Cu	Grease lub.	Oil lub.				da	db	Da	Db	Sa	Sb	ra	rb		Y1	Y0		
															min	max	max	min	min	min	max	max					
25	52	22	22	18	1	1	61.1	58.5	8.25	7900	10000	33205JR	2DE	14.1	30.5	30	46.5	43	49	4	4	1	1	0.35	1.71	0.94	0.225
30	62	25	25	19.5	1	1	83.1	79.4	11.6	6500	8700	33206JR	2DE	16.3	35.5	36	56.5	53	59	5	5.5	1	1	0.34	1.76	0.97	0.359
35	72	28	28	22	1.5	1.5	110	107	15.8	5700	7500	33207JR	2DE	18.4	43.5	42	63.5	61	68	5	6	1.5	1.5	0.35	1.70	0.93	0.551
40	80	32	32	25	1.5	1.5	135	139	20.8	5000	6700	33208JR	2DE	20.7	48.5	47	71.5	67	76	5	7	1.5	1.5	0.36	1.68	0.92	0.758
45	85	32	32	25	1.5	1.5	139	149	22.3	4600	6200	33209JR	3DE	21.8	53.5	52	76.5	72	81	5	7	1.5	1.5	0.39	1.56	0.86	0.818
50	90	32	32	24.5	1.5	1.5	150	167	25.0	4300	5700	33210JR	3DE	23.1	58.5	57	81.5	77	86.5	5	7.5	1.5	1.5	0.41	1.45	0.80	0.887
55	100	35	35	27	2	1.5	178	189	28.9	3900	5200	33211JR	3DE	25.3	65	62	90	85	96	6	8	2	1.5	0.40	1.50	0.83	1.18
60	110	38	38	29	2	1.5	217	239	36.6	3600	4700	33212JR	3EE	27.2	70	69	100	93	105	6	9	2	1.5	0.40	1.48	0.82	1.57
65	120	41	41	32	2	1.5	250	277	43.0	3200	4300	33213JR	3EE	30	75	74	110	102	115	7	9	2	1.5	0.39	1.54	0.85	2.02
70	125	41	41	32	2	1.5	258	294	45.5	3100	4100	33214JR	3EE	31.2	80	79	116.5	107	120	7	9	2	1.5	0.41	1.47	0.81	2.16
75	130	41	41	31	2	1.5	266	310	47.7	2900	3900	33215JR	3EE	32.5	85	83	121.5	111	125	7	10	2	1.5	0.43	1.40	0.77	2.26
80	140	46	46	35	2.5	2	313	371	56.1	2700	3600	33216JR	3EE	35.7	92	89	130	119	135	7	11	2	2	0.43	1.41	0.78	2.99
85	150	49	49	37	2.5	2	368	439	59.1	2500	3400	33217JR	3EE	37.1	97	95	140	128	144	7	12	2	2	0.42	1.43	0.79	3.63
95	170	58	58	44	3	2.5	468	582	74.0	2200	2900	33219JR	3FE	42.8	109	107	158	144	163	9	14	2.5	2	0.41	1.47	0.81	5.66
100	180	63	63	48	3	2.5	540	680	85.8	2100	2800	33220JR	3FE	45.7	114	112	168	151	172	10	15	2.5	2	0.40	1.48	0.82	6.92

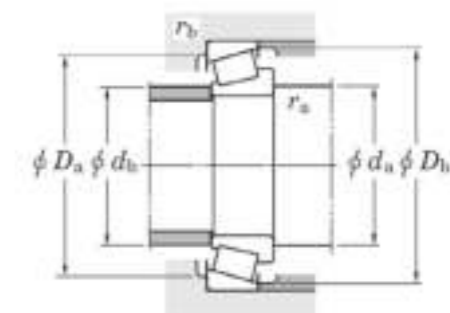
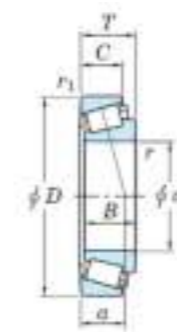
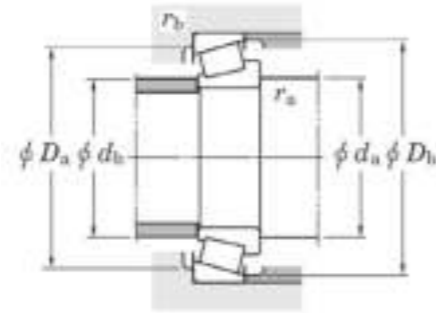
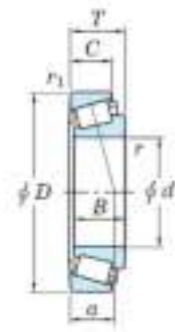

Boundary dimensions(mm)							Basic load ratings(kN)		Fatigue load limit(kN)	Limiting speeds(min-1)		Bearing No.	Load center (mm)	Mounting dimensions						Constant	Axial load factors		Mass				
d	D	T	B	C	r min.	r1 min.	Cr	Cor	Cu	Grease lub.	Oil lub.			Inner ring	Outer ring	da	db	Da	Db		ra max	rb max	e	Y1	Y0	Inner ring	Outer ring
50.8	92.075	24.608	25.4	19.845	3.6	0.8	107	119	17.9	4 200	5 600			28580R	28521	19.9	63	57	83		87	3.6	0.8	0.38	1.59	0.87	0.453
50.8	88.9	20.638	22.225	16.513	3.6	1.2	92.9	87.3	13.3	4 400	5 800	368A	362A	16.1	62	56	81	84	3.6	1.2	0.32	1.88	1.03	0.331	0.164		
50.8	93.264	30.162	30.302	23.812	3.6	3.2	129	137	20.9	4 200	5 500	3780	3720	22.2	64	58	82	88	3.6	3.2	0.34	1.77	0.97	0.547	0.288		
52.388	92.075	24.608	25.4	19.845	3.6	0.8	107	119	17.9	4 200	5 600	28584R	28521	19.9	65	58	83	87	3.6	0.8	0.38	1.59	0.87	0.453	0.247		
55	90	23	23	18.5	1.6	0.5	102	115	17.2	4 200	5 500	JLM506849	JLM506810	20.1	63	61	82	86	1.6	0.5	0.4	1.49	0.82	0.37	0.183		
55.562	97.63	24.608	24.608	19.446	3.6	0.8	113	131	19.7	3 900	5 200	28680	28622	21.2	68	62	88	92	3.6	0.8	0.4	1.49	0.82	0.492	0.267		
57.15	96.838	21	21.946	15.875	3.6	0.8	101	101	15.3	3 900	5 200	387A	382A	17.4	69	62	89	92	3.6	0.8	0.35	1.69	0.93	0.426	0.177		
57.15	96.838	21	21.946	15.875	5.2	0.8	101	101	15.3	3 900	5 200	387AS	382A	17.4	72	62	89	92	5.2	0.8	0.35	1.69	0.93	0.422	0.177		
60.325	101.6	25.4	25.4	19.845	3.6	3.2	115	137	20.6	3 700	4 900	28985	28920	22.8	73	67	89	96	3.6	3.2	0.43	1.41	0.78	0.533	0.269		
60.325	101.6	25.4	25.4	19.845	3.6	3.2	115	137	20.6	3 700	4 900	28985	28921	22.8	73	67	89	96	3.6	3.2	0.43	1.41	0.78	0.533	0.23		
63.5	112.712	30.162	30.162	23.812	3.6	3.2	184	207	32.1	3 300	4 500	39585	39520	23.3	77	71	101	107	3.6	3.2	0.34	1.77	0.97	0.908	0.355		
63.5	136.525	41.275	41.275	31.75	3.6	3.2	302	308	48.1	2 900	3 800	H414235	H414210	30.3	82	78	121	129	3.6	3.2	0.36	1.67	0.92	2.11	0.796		
66.675	122.238	38.1	38.354	29.718	3.6	1.6	238	249	39.1	3 200	4 300	HM212049	HM212010	27.3	82	75.5	110	116	3.6	1.6	0.34	1.78	0.98	1.26	0.596		
71.438	136.525	41.275	41.275	31.75	3.6	3.2	284	308	46.1	2 900	3 800	H414249	H414210	30.3	89	83.3	121	129	3.6	3.2	0.36	1.67	0.92	1.8	0.788		
80.962	150.089	44.45	46.672	36.512	5.2	3.2	330	368	50.1	2 500	3 400	740R	742	32.4	101	91	134	142	5.2	3.2	0.33	1.84	1.01	2.3	1.06		
82.55	139.992	36.512	36.098	28.575	3.6	3.2	220	262	39.8	2 700	3 600	580R	572	31	98	91	125	133	3.6	3.2	0.4	1.49	0.82	1.41	0.779		
82.55	150.089	44.45	46.672	36.512	3.6	3.2	330	368	50.1	2 500	3 400	749AR	742	32.4	99	93	134	142	3.6	3.2	0.33	1.84	1.01	2.23	1.06		
88.9	161.925	53.975	55.1	42.862	3.6	3.2	395	471	61.4	2 400	3 200	6580R	6535	49.8	109	98	141	154	3.6	3.2	0.4	1.5	0.82	3.09	1.65		
88.9	152.4	39.688	39.688	30.162	6.4	3.2	311	359	53.5	2 400	3 200	HM518445	HM518410	33.1	110	98	135	146	6.4	3.2	0.4	1.49	0.82	2.1	0.768		
89.974	146.975	40	40	32.5	7.1	3.6	259	310	46.6	2 500	3 300	HM218248	HM218210	30.8	112	99	133	141	7.1	3.6	0.33	1.8	0.99	1.66	0.784		
95.25	147.638	35.717	36.322	26.192	5.2	0.8	230	287	42.5	2 400	3 300	594A	592XE	33.4	113	104	135	142	5.2	0.8	0.44	1.36	0.75	1.45	0.62		
101.6	212.725	66.675	66.675	53.975	7.1	3.2	563	674	84.1	1 800	2 400	941	932	47.6	121	135	181	192	7.1	3.2	0.33	1.84	1.01	7.07	4.07		
114.3	212.725	66.675	66.675	53.975	7.1	3.2	563	674	84.1	1 800	2 400	938	932	47.6	141	128	187	193	7.1	3.2	0.33	1.84	1.01	5.96	4.07		

Tapered Roller Bearings Imperial Series

Koyo

Finer Power Transmissions P/L | www.finerpt.com

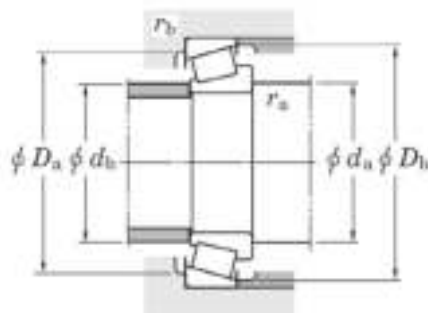
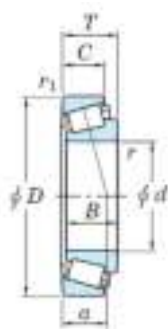

Boundary dimensions(mm)					Bearing No.	Set No.
d	D	T	B	C		
15.875	42.863	14.288	14.288	9.525	11590/20	-
25.4	50.005	13.495	14.26	9.525	07100/196	15
25.4	65.088	22.225	21.463	15.875	23100/256	-
25.4	57.15	19.431	19.431	14.732	M84548/10	308
30.162	62	21.432	16.566	16.670	M86649/10	-
30.162	68.262	22.225	22.225	17.462	M88043/10	-
31.75	69.012	19.845	19.583	15.875	14125A/276	-
31.75	69.85	23.813	25.357	19.05	2580/23	95
31.75	59.131	15.875	16.764	11.811	LM67049A/10	-
33.338	68.262	22.225	22.225	17.462	M88048/10	63
34.925	69.0118	19.845	19.583	15.875	14137A/276	-
34.925	69.0118	-	39.7	-	14138A/276	-
34.925	73.025	23.812	24.608	19.050	25877R/21	260
34.925	76.2	29.37	28.575	23.02	HM89446/10	100
36.513	76.2	29.37	28.575	23.02	HM89448/10	-
36.513	76.2	29.37	28.575	23.02	HM89449/10	312
38.1	76.2	23.775	23.8125	19.050	2788R/20	230
39.69	76.2	23.775	23.81	19.050	2789R/20	-
40	80	-	19.75	-	57307/30208J	-
40.988	67.975	17.501	18.001	13.5	LM300849/11	318
41.275	80.16	25.4	25.4	20.638	26882R/20	-
41.28	79.38	23.813	19.05	19.05	26882R/22	-
42.86	87.31	30.163	30.89	23.812	3579R/25	351
42.875	82.93	26.988	25.4	22.225	25577/23	-
44.45	83.058	23.876	25.4	19.114	25580/22	122
44.45	95.25	30.958	28.575	22.225	HM903249/10	64
45.23	79.985	19.842	20.638	15.08	17887/31	62
45.23	79.985	19.842	20.6	15.08	17887YA1/31	-
45.618	82.931	23.813	25.4	19.05	25590/20	54
45.987	74.976	18.000	18.000	14.00	LM503349A/10	-
50	84	22.00	22	17.50	JLM704649/10	-
50.8	82.55	21.59	22.225	16.510	LM104949/11	38
57.15	97.63	24.608	24.608	19.446	28682/22	407
57.15	104.775	30.162	29.317	24.605	469/453X	205
63.5	110.000	22.000	21.996	18.824	395/394A	365
63.5	112.7125	30.163	30.048	23.813	3982/20	103
63.5	122.2375	38.100	38.1	29.718	HM212047YA/11	412
66.675	112.713	30.163	30.048	23.813	3984/20	98
66.675	122.238	38.100	38.354	29.718	HM212049/10	99
66.675	112.712	30.162	30.162	23.812	39590/20	-
73.025	127.000	36.512	36.170	28.575	567/563	425
82.55	133.35	33.338	33.338	26.195	47686/620	-

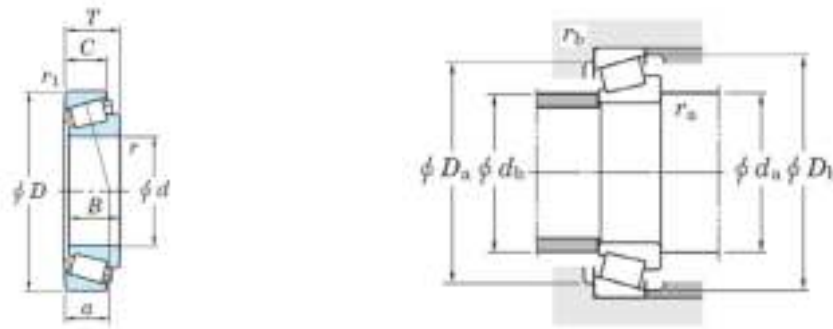

Boundary dimensions(mm)					Bearing No.	Set No.
d	D	T	B	C		
82.55	133.35	39.000	39.688	31.500	HM516449/10	421
92.075	152.4	39.688	36.322	30.163	598A/592A	404
114.3	212.725	66.675	66.675	53.975	938/932	-

Trailer Bearing Kits KOYO Premium Trailer Bearing Kits



KOYO Premium Trailer Bearing Kits (with Seagull Oil Seals)						
Type	Part	Bearings	Bearings	Seal	Split Pin	Dust Cap
Ford Marine Kit	TBK-FM/KOYO	Set 12	Set 13	PR6692	Yes	Yes
Holden Marine Kit	TBK-HM/KOYO	Set 2	Set 6	PR6641	Yes	Yes
Ford Trailer Kit	TBK-FR/KOYO	Set 12	Set 13	C610	Yes	Yes
Holden Trailer Kit	TBK-HR/KOYO	Set 2	Set 6	C609A	Yes	Yes

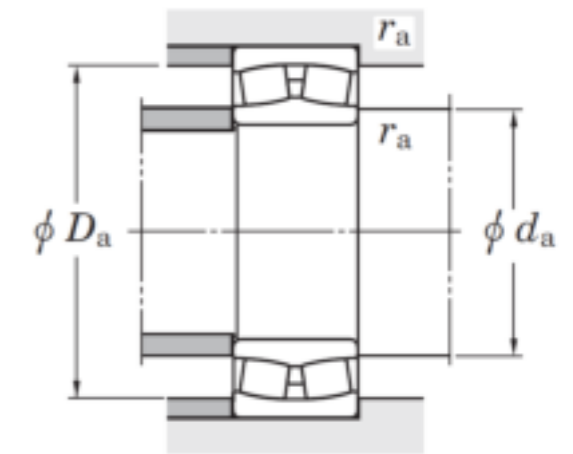
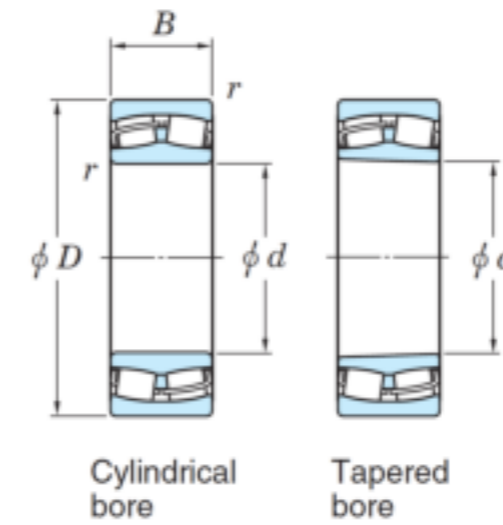
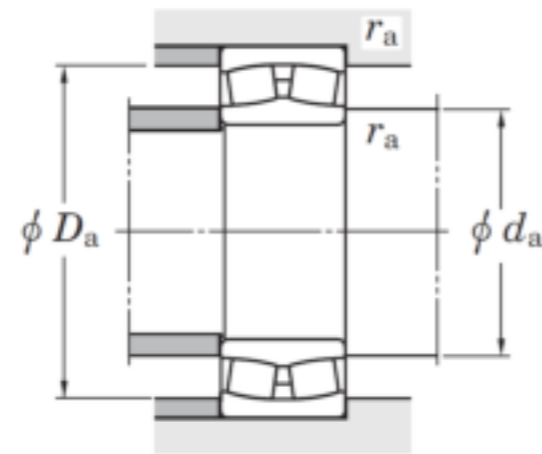
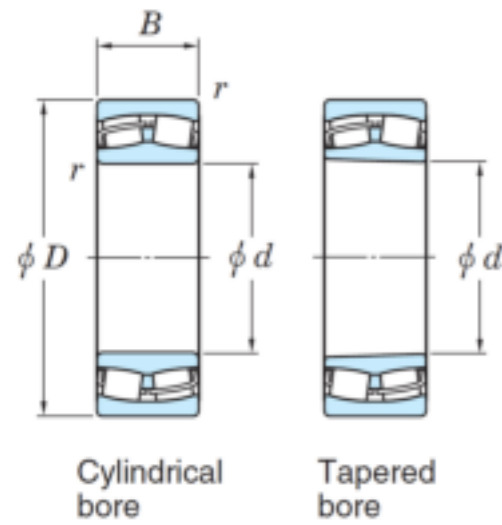

Boundary dimensions(mm)				Basic load ratings(kN)		Fatigue load limit(kN)	Limiting speeds		Bearing No.		Mounting dimensions(mm)					Constant	Axial load factors			Mass (kg)	
d	D	B	r min.	Cr	Cor	Cu	Grease lub.	Oil lub.	Cylindrical bore	Tapered bore	da		Da		ra	e	Y1	Y2	Y3	Cylindrical bore	Tapered min. bore
											min.	max.	max.	min.							
25	52	18	1	56.8	48.1	3.9	9600	12800	22205RZ	22205RZK	31	31	46	46	1	0.35	1.91	2.85	1.87	0.188	0.184
30	62	20	1	76.6	65.9	5.3	8100	10900	22206RZ	22206RZK	36	36.5	56	55.5	1	0.33	2.04	3.04	2	0.296	0.29
35	72	23	1.1	100	88.7	7.75	6900	9200	22207RZ	22207RZK	42	42.5	65	64	1	0.32	2.09	3.11	2.04	0.459	0.449
40	80	23	1.1	114	102	9.55	6200	8300	22208RZ	22208RZK	47	49	73	72.5	1	0.28	2.37	3.53	2.32	0.602	0.591
45	85	23	1.1	119	110	10.2	5800	7700	22209RZ	22209RZK	52	53.5	78	77.5	1	0.26	2.55	3.8	2.5	0.602	0.59
50	90	23	1.1	128	122	12.7	5400	7200	22210RZ	22210RZK	57	58.5	83	82.5	1	0.24	2.79	4.15	2.73	0.648	0.634
55	100	25	1.5	154	144	15	4700	6300	22211RZ	22211RZK	63.5	64	91.5	91.5	1.5	0.24	2.84	4.23	2.78	0.867	0.849
60	110	28	1.5	190	181	18.7	4300	5800	22212RZ	22212RZK	68.5	70	101.5	100	1.5	0.25	2.74	4.08	2.68	1.19	1.17
65	120	31	1.5	222	211	20.7	4000	5200	22213RZ	22213RZK	73.5	76	111.5	109	1.5	0.25	2.69	4	2.63	1.55	1.52
70	125	31	1.5	233	222	24.4	3700	5000	22214RZ	22214RZK	78.5	80	116.5	114	1.5	0.24	2.87	4.27	2.8	1.64	1.61
75	130	31	1.5	241	236	28.2	3600	4700	22215RZ	22215RZK	83.5	85.5	121.5	119	1.5	0.22	3.07	4.57	3	1.73	1.69
75	130	31	-	-	-	-	-	-	22215RHR	-	-	-	-	-	-	-	-	-	-	-	-
80	140	33	2	271	271	30.5	3300	4400	22216RZ	22216RZK	90	92	130	128	2	0.22	3.07	4.57	3	2.17	2.13
85	150	36	2	322	324	35.7	3000	4100	22217RZ	22217RZK	95	97	140	137	2	0.22	3.01	4.48	2.94	2.75	2.69
90	160	40	2	372	381	39.2	2900	3900	22218RZ	22218RZK	100	104	150	145	2	0.24	2.79	4.15	2.73	3.5	3.43
95	170	43	2.1	417	422	42.7	2800	3600	22219RZ	22219RZK	107	109	158	154	2	0.24	2.76	4.11	2.7	4.24	4.15
100	180	46	2.1	470	481	47.6	2600	3400	22220RZ	22220RZK	112	115	168	163	2	0.25	2.74	4.08	2.68	5.11	5
120	215	58	2.1	706	764	67.2	2100	2800	22224RZ	22224RZK	132	138	203	193	2	0.26	2.6	3.87	2.54	9.31	9.1
130	230	64	3	821	914	74.4	1900	2600	22226RZ	22226RZK	144	148	216	206	2.5	0.26	2.55	3.8	2.5	11.6	11.3
140	250	68	3	947	1030	85.2	1800	2300	22228RZ	22228RZK	154	158	236	224	2.5	0.26	2.6	3.87	2.54	14.5	14.2
150	270	73	3	1080	1200	102	1700	2200	22230RZ	22230RZK	164	172	256	243	2.5	0.25	2.69	4	2.63	18.9	18.5

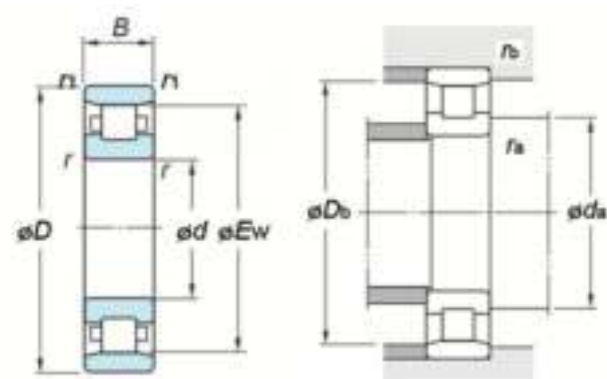

N

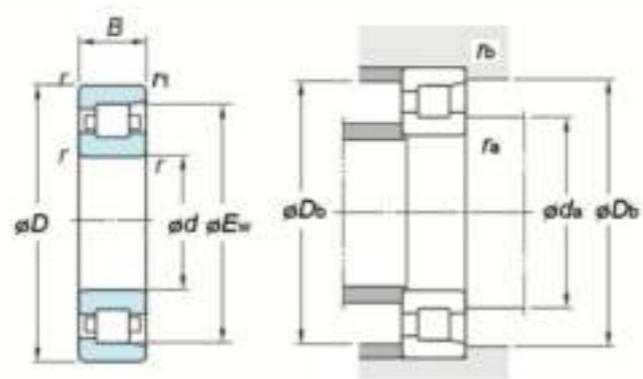

NF

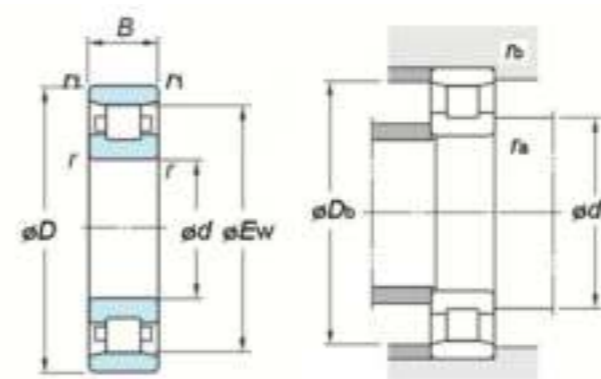

N

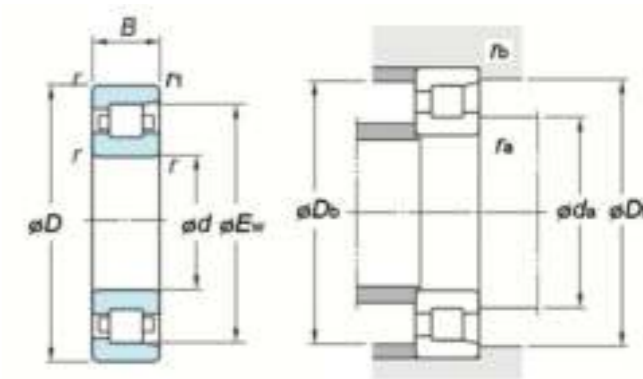

NF

Boundary dimensions						Basic load ratings (kN)		Fatigue load limit(kN)	Limiting speed		Bearing No.		Mounting dimensions						Mass NU (kg)		
d	D	B	r min.	r1 min.	Ew	Cr	Cor	Cu	Grease lub	Oil lub.	N	NF	da	dd	Da	Db		ra		rb	
													min.	min.	max.	max.	min.	max.	max.		
20	47	14	1	0.6	40	19.3	12.7	1.45	15 000	18 000	N204	NF204	25	32	42	43	42	1	0.6	0.108	
	52	15	1.1	0.6	44.5	28.9	19.2	2.5	12000	16000	N304	NF304	26.5	33	45.5	48	45.5	1	0.6	0.147	
25	52	15	1	0.6	45	22.1	15.7	1.8	13 000	16 000	N205	NF205	30	37	47	48	47	1	0.6	0.132	
	62	17	1.1	1.1	53	36.6	25.2	3.45	10 000	14 000	N305	NF305	31.5	40	55.5	55.5	55	1	1	0.235	
30	62	16	1	0.6	53.5	31.1	21.5	2.95	11 000	13 000	N206	NF206	35	44	57	58	56	1	0.6	0.206	
	72	19	1.1	1.1	62	48.3	35.2	5	8 700	12 000	N306	NF306	36.5	48	65.5	65.5	64	1	1	0.353	
35	72	17	1.1	0.6	61.8	44.6	31.5	4.7	9 500	11 000	N207	NF207	41.5	50	65.5	68	64	1	0.6	0.293	
	80	21	1.5	1.1	68.2	62	46.9	6.2	7 900	10 000	N307	NF307	43	53	72	73.5	71	1.5	1	0.477	
40	80	18	1.1	1.1	70	54.7	42.9	6.15	8 300	10 000	N208	NF208	46.5	56	73.5	73.5	72	1	1	0.374	
	90	23	1.5	1.5	77.5	73.4	56.9	7.85	6 900	9 100	N308	NF308	48	60	82	82	80	1.5	1.5	0.646	
45	85	19	1.1	1.1	75	57.6	46.9	6.7	7 700	9 200	N209	NF209	51.5	61	78.5	78.5	77	1	1	0.427	
	100	25	1.5	1.5	86.5	98.5	77.5	11.3	6 200	8 300	N309	NF309	53	66	92	92	89	1.5	1.5	0.865	
50	90	20	1.1	1.1	80.4	60.3	51	7.3	7 100	8 500	N210	NF210	56.5	67	83.5	83.5	82	1	1	0.479	
	110	27	2	2	95	109	93.4	11.7	5 600	7 500	N310	NF310	59	73	101	101	98	2	2	1.15	
55	100	21	1.5	1.1	88.5	72.5	62.3	8.3	6 400	7 700	N211	NF211	63	73	92	93.5	91	1.5	1	0.633	
	120	29	2	2	104.5	138	111	15.8	5 100	6 800	N311	NF311	64	80	111	111	107	2	2	1.44	
60	110	22	1.5	1.5	97.5	85.7	79.9	10.4	5 800	7 000	N212	NF212	68	80	102	102	100	1.5	1.5	0.823	
	130	31	2.1	2.1	113	155	126	17.3	4 700	6 300	N312	NF312	71	86	119	119	116	2	2	1.83	
65	120	23	1.5	1.5	105.6	105	94.4	13.5	5 400	6 400	N213	NF213	73	87	112	112	108	1.5	1.5	1.05	
	140	33	2.1	2.1	121.5	169	139	19.2	4 300	5 800	N313	NF313	76	93	129	129	125	2	2	2.19	
70	125	24	1.5	1.5	110.5	104	95.2	13.6	5 100	6 100	N214	NF214	78	92	117	117	114	1.5	1.5	1.50	
	150	35	2.1	2.1	130	198	168	23.3	4 000	5 400	N314	NF314	81	100	139	139	134	2	2	2.73	
75	130	25	1.5	1.5	116.5	121	118	16.1	4 800	5 800	N215	NF215	83	96	122	122	120	1.5	1.5	1.24	
	160	37	2.1	2.1	139.5	224	205	28.4	3 800	5 000	N315	NF315	86	106	149	149	143	2	2	3.19	
80	140	26	2	2	125.3	133	122	16.2	4 500	5 400	N216	NF216	89	104	131	131	128	2	2	1.51	
	170	39	2.1	2.1	147	238	207	30.7	3 500	4 700	N316	NF316	91	114	159	159	151	2	2	3.83	
85	150	28	2	2	133.8	151	140	18.7	4 200	5 000	N217	NF217	94	110	141	141	137	2	2	1.9	
	180	41	3	3	156	281	247	35.6	3 300	4 500	N317	NF317	98	119	167	167	160	2.5	2.5	4.52	
90	160	30	2	2	143	190	178	22.9	3 900	4 700	N218	NF218	99	116	151	151	146	2	2	2.32	
	190	43	3	3	165	300	265	38.7	3 100	4 200	N318	NF318	103	127	177	177	169	2.5	2.5	5.27	

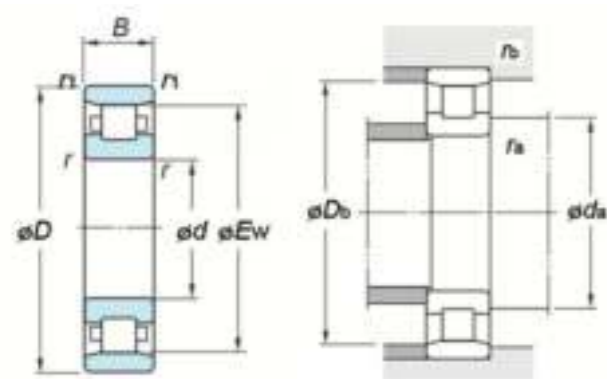

N

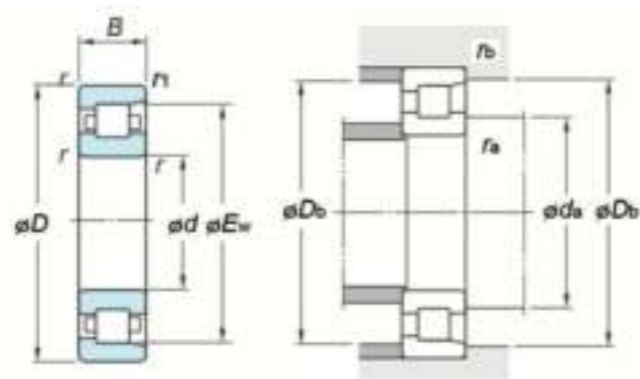

NF

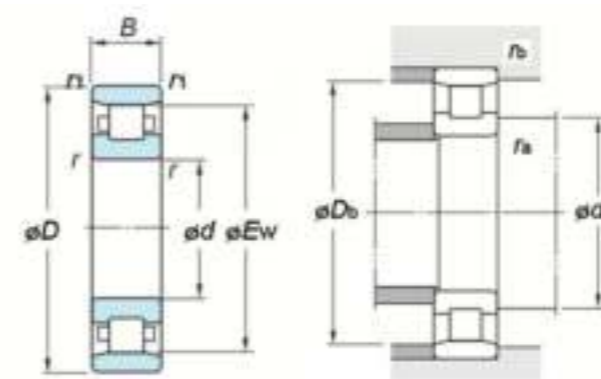

N

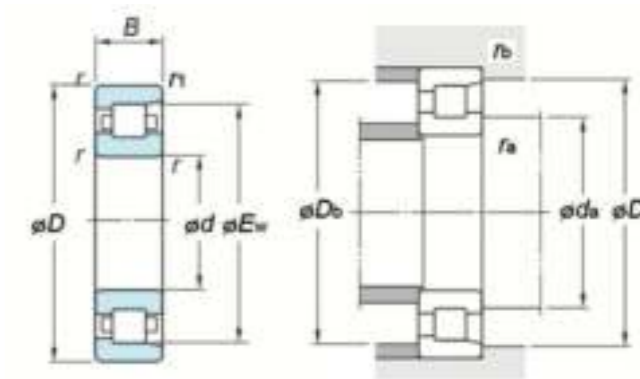

NF

Boundary dimensions						Basic load ratings (kN)		Fatigue load limit(kN)	Limiting speed		Bearing No.		Mounting dimensions						Mass NU (kg)		
d	D	B	r min.	r1 min.	Ew	Cr	Cor	Cu	Grease lub	Oil lub.	N	NF	da	dd	Da	Db		ra		rb	
													min.	min.	max.	max.	min.	max.	max.		
95	170	32	2.1	2.1	151.5	207	195	25.1	3700	4400	N219	NF219	106	123	159	159	155	2	2	2.8	
	200	45	3	3	173.5	323	0.311	41.3	3000	4000	N319	NF319	108	134	187	187	178	2.5	2.5	6.1	
100	180	34	2.1	2.1	160	229	217	28.1	3500	4200	N220	NF220	111	130	169	169	164	2	2	3.38	
	215	47	3	3	185.5	373	337	47.2	2800	3700	N320	NF320	113	143	202	202	190	2.5	2.5	7.59	
110	240	50	3	3	207	475	467	58.4	2500	3300	N322	NF322	120	158	227	227	211	2.5	2.5	10.4	
120	215	40	2.1	2.1	191.5	325	318	42.9	2900	3400	N224	NF224	131	156	204	204	196	2	2	6.31	
	260	55	3	3	226	561	551	67.1	2200	3000	N324	NF324	133	171	247	247	230	2.5	2.5	13.1	
130	230	40	3	3	204	338	362	45.2	2700	3200	N226	NF226	143	168	217	217	208	2.5	2.5	7.21	
	280	58	4	4	243	699	667	85.7	2100	2700	N326	NF326	146	184	264	264	247	3	3	16.4	
140	250	42	3	3	221	406	421	55.5	2400	2900	N228	NF228	153	182	237	237	228	2.5	2.5	8.78	
	300	62	4	4	260	771	746	93.8	1900	2500	N328	NF328	156	198	284	284	264	3	3	21.8	
150	270	45	3	3	238	468	492	65.4	2200	2700	N230	NF230	163	196	257	257	2.5	2.5	2.5	2.5	11.1
	320	65	4	4	277	829	807	99.1	1800	2300	N330	NF330	166	213	304	304	281	3	3	25.6	

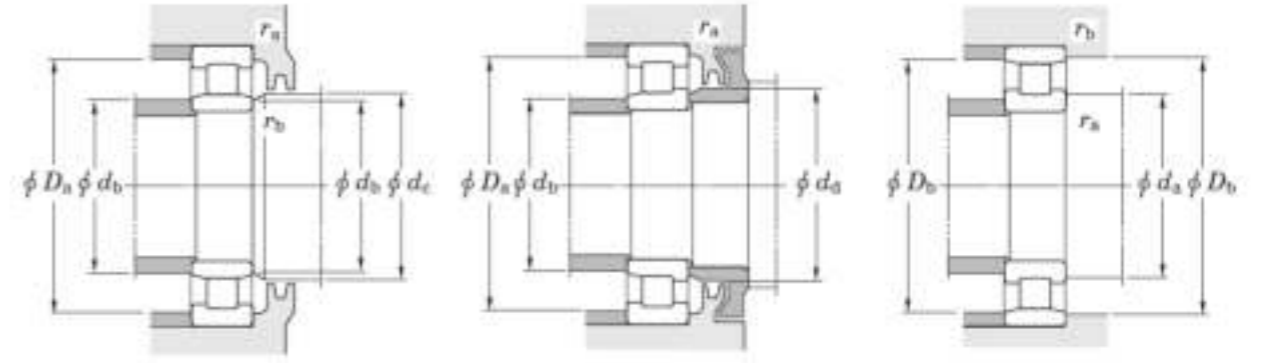
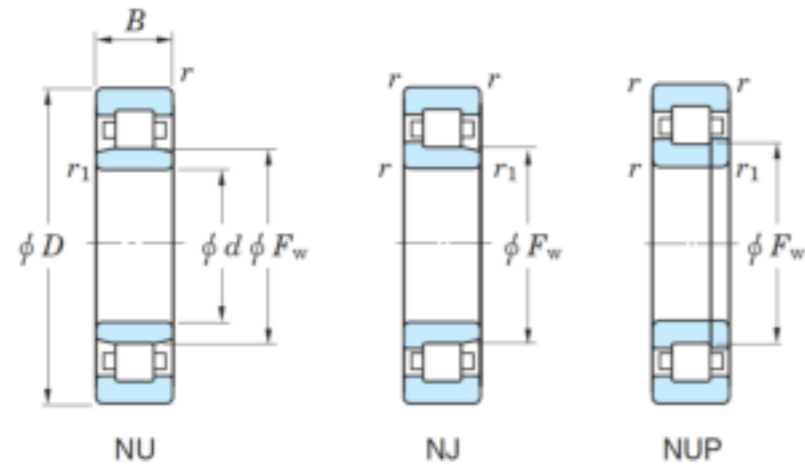

Boundary dimensions						Basic load ratings (kN)		Fatigue load limit(kN)	Limiting speed		Bearing No.			Mounting dimensions						Mass NU (N) (kg)			
d	D	B	r min.	r1 min.	Fw	Cr	Cor	Cu	Grease lub	Oil lub.	NU	NJ	NUP	da	db		dc	dd	Da		ra	rb	
														min.	min.	max.	min.	min.	max.		max.	max.	
15	35	11	-	-	-	-	-	-	-	-	NU202E-TVP2	-	-	-	-	-	-	-	-	-	-	-	
	40	12	-	-	-	-	-	-	-	-	-	NJ203	-	-	-	-	-	-	-	-	-	-	
	17	40	12	-	-	-	-	-	-	-	-	NU203E-TVP2	-	NUP203E-TVP2	-	-	-	-	-	-	-	-	
		40	16	-	-	-	-	-	-	-	-	-	NJ2203E-TVP2	-	-	-	-	-	-	-	-	-	
20	40	47	-	-	-	-	-	-	-	-	-	-	NUP303E-TVP2	-	-	-	-	-	-	-	-		
	47	14	1	0.6	26.5	32.2	22.6	3.05	15 000	18 000	NU204R	NJ204R	NUP204R	25	24	26	29	32	42	1	0.6	0.112	
	47	14	-	-	-	-	-	-	-	-	NU204	NJ204	-	-	-	-	-	-	-	-	-	-	
	47	14	-	-	-	-	-	-	-	-	NU204E-TVP2	-	NUP204E-TVP2	-	-	-	-	-	-	-	-	-	
	47	18	1	0.6	27	27.8	18.4	2.7	13000	18000	NU2204	NJ2204	NUP2204	25	24	26	29	32	42	1	0.6	0.146	
	47	18	-	-	-	-	-	-	-	-	-	NJ2204E-TVP2	-	-	-	-	-	-	-	-	-	-	-
	52	15	1.1	0.6	27.5	39.4	26.9	3.75	12000	16000	NU304R	NJ304R	NUP304R	26.5	24	27	30	33	45.5	1	0.6	0.153	
	52	15	-	-	-	-	-	-	-	-	-	NU304	NJ304	NUP304	-	-	-	-	-	-	-	-	-
25	52	15	-	-	-	-	-	-	-	-	-	-	NUP304E-TVP2	-	-	-	-	-	-	-	-	-	
	47	12	0.6	0.3	30.5	17.8	13.1	2.25	15 000	18 000	NU1005	-	NUP1005	29	27	30	32	-	43	0.6	0.3	0.084	
	52	15	1	0.6	31.5	36.7	27.7	3.75	13 000	15 000	NU205R	NJ205R	NUP205R	30	29	31	34	37	47	1	0.6	0.138	
	52	15	-	-	-	-	-	-	-	-	NU205	NJ205	-	-	-	-	-	-	-	-	-	-	
	52	15	-	-	-	-	-	-	-	-	NU205E-TVP2	-	NUP205E-TVP2	-	-	-	-	-	-	-	-	-	
	52	18	1	0.6	32	29.6	22.8	3.05	12 000	16 000	NU2205	NJ2205	NUP2205	30	29	31	34	37	47	1	0.6	0.163	
	52	18	-	-	-	-	-	-	-	-	-	-	NUP2205E-TVP2	-	-	-	-	-	-	-	-	-	-
	62	24	1.1	1.1	35	53.4	40.9	5.7	9 100	14 000	NU2305	NJ2305	NUP2305	31.5	31.5	33	37	40	55.5	1	1	0.34	
	62	17	1.1	1.1	34	51.9	37.4	4.85	10 000	14 000	NU305R	NJ305R	NUP305R	31.5	31.5	33	37	40	55.5	1	1	0.243	
	62	17	-	-	-	-	-	-	-	-	-	NJ305	-	-	-	-	-	-	-	-	-	-	-
62	17	-	-	-	-	-	-	-	-	-	-	NUP305E-TVP2	-	-	-	-	-	-	-	-	-	-	

TVP = Poly cage
R = Poly cage extra capacity

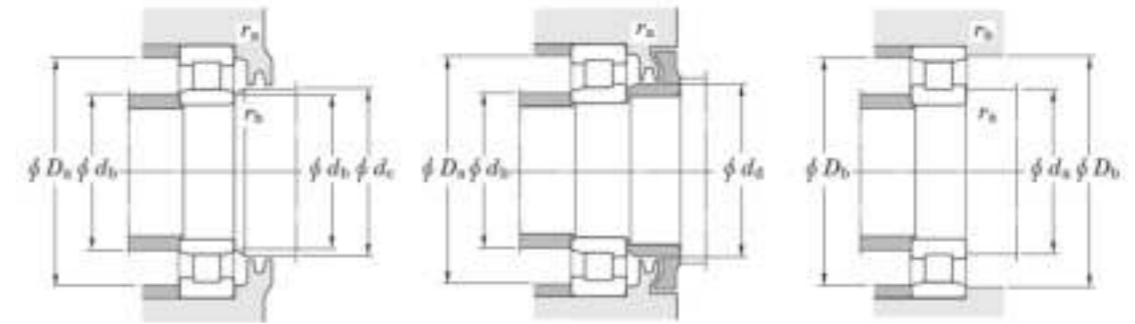
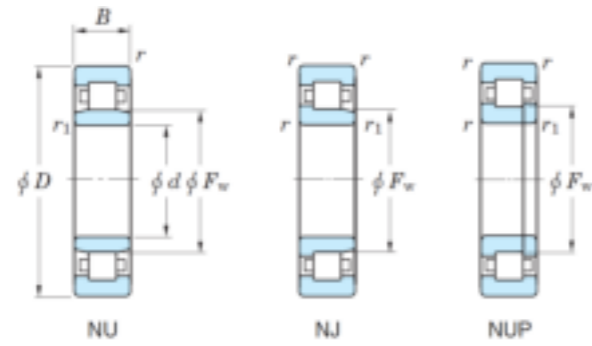

d	Boundary dimensions					Basic load ratings (kN)		Fatigue load limit(kN)	Limiting speed		Bearing No.			Mounting dimensions							Mass NU (N) (kg)		
	D	B	r min.	r1 min.	Fw	Cr	Cor	Cu	Grease lub	Oil lub.	NU	NJ	NUP	da	db		dc	dd	Da	ra		rb	
														min.	min.	max.	min.	min.	max.	max.		max.	
30	55	13	1	0.6	36.5	23.4	18.4	2.05	13 000	15 000	NU1006	-	NUP1006	35	34	35	38		50	1	0.6	0.121	
	62	16	1	0.6	37.5	48.9	37.4	5.25	11 000	13 000	NU206R	NJ206R	NUP206R	35	34	37	40	44	57	1	0.6	0.209	
	62	16	-	-	-	-	-	-	-	-	NU206E-TVP2	-	NUP206E-TVP2	-	-	-	-	-	-	-	-	-	
	62	16	-	-	-	-	-	-	-	-	-	NJ206	-	-	-	-	-	-	-	-	-	-	
	62	20	1	0.6	38.5	41	33.1	4.2	9 800	13 000	NU2206	NJ2206	NUP2206	35	3	37	40	44	57	1	0.6	0.262	
	62	20	-	-	-	-	-	-	-	-	-	-	NUP2206E-TVP2	-	-	-	-	-	-	-	-	-	-
	72	27	1.1	1.1	42	64.3	50.8	7.15	7 700	12 000	NU2306	NJ2306	NUP2306	36.5	36.5	40	44	48	65.5	1	1	0.5	
	72	19	-	-	-	-	-	-	-	-	-	NU306	NJ306	NUP306	-	-	-	-	-	-	-	-	-
	72	19	1.1	1.1	40.5	66.5	50.2	6.8	8 700	12 000	NU306R	NJ306R	NUP306R	36.5	36.5	40	44	48	65.5	1	1	0.361	
											-	-	NUP306E-TVP2	-	-	-	-	-	-	-	-	-	
35	62	14	1	0.6	42	28.3	23.2	2.65	11 000	13 000	NU1007	-	NUP1007	40	39	41	44		57	1	0.5	0.182	
	72	17	1.1	0.6	44	62.9	50.2	6.55	9 300	11 000	NU207R	NJ207R	NUP207R	41.5	39	43	46	50	65.5	1	0.6	0.306	
	72	17	-	-	-	-	-	-	-	-	NU207	NJ207	-	-	-	-	-	-	-	-	-	-	
	72	17	-	-	-	-	-	-	-	-	NU207E-TVP2	-	NUP207E-TVP2C3	-	-	-	-	-	-	-	-	-	
	72	23	1.1	0.6	43.8	61.3	51.2	7.15	8 500	11 000	NU2207	NJ2207	NUP2207	41.5	39	43	46	50	65.5	1	0.6	0.402	
	72	23	-	-	-	-	-	-	-	-	-	-	NUP2207R	-	-	-	-	-	-	-	-	-	-
	72	23	-	-	-	-	-	-	-	-	-	-	NUP2207E-TVP2	-	-	-	-	-	-	-	-	-	-
	80	31	1.5	1.1	46.2	75.5	65.7	7.95	7 000	10 000	NU2307	NJ2307	NUP2307	43	41.5	45	48	53	72	1.5	1	0.696	
	80	21	-	-	-	-	-	-	-	-	-	NU307	NJ307	NUP307	-	-	-	-	-	-	-	-	-
80	21	1.5	1.1	46.2	83.3	65.4	9.35	7 700	10 000	NU307R	NJ307R	NUP307R	43	41.5	45	48	53	72	1.5	1	0.482		
40	68	15	1	0.6	47	31.2	25.7	3.1	10 000	12 000	NU1008	-	NUP1008	45	44	46	49		63	1	0.6	0.223	
	80	18	1.1	1.1	49.5	69.6	55.4	7.35	8 300	9 900	NU208R	NJ208R	NUP208R	46.5	46.5	49	52	56	73.5	1	1	0.384	
	80	18	-	-	-	-	-	-	-	-	NU208	NJ208	NUP208	-	-	-	-	-	-	-	-	-	
	80	23	1.1	1.1	50	72.8	62	8.75	7 500	10 000	NU2208	NJ2208	NUP2208	46.5	46.5	49	52	56	73.5	1	1	0.490	
	80	23	-	-	-	-	-	-	-	-	-	-	NUP2208R	-	-	-	-	-	-	-	-	-	
	90	33	1.5	1.5	53.5	103	88	11.6	6 100	9 100	NU2308	NJ2308	NUP2308	48	48	51	55	60	82	1.5	1.5	0.956	
	90	23	-	-	-	-	-	-	-	-	NU308	NJ308	NUP308	-	-	-	-	-	-	-	-	-	
	90	23	1.5	1.5	52	104	81.5	11	6 800	9 100	NU308R	NJ308R	NUP308R	48	48	51	55	60	82	1.5	1.5	0.664	
	90	23	-	-	-	-	-	-	-	-	-	-	NUP308E-TVP	-	-	-	-	-	-	-	-	-	

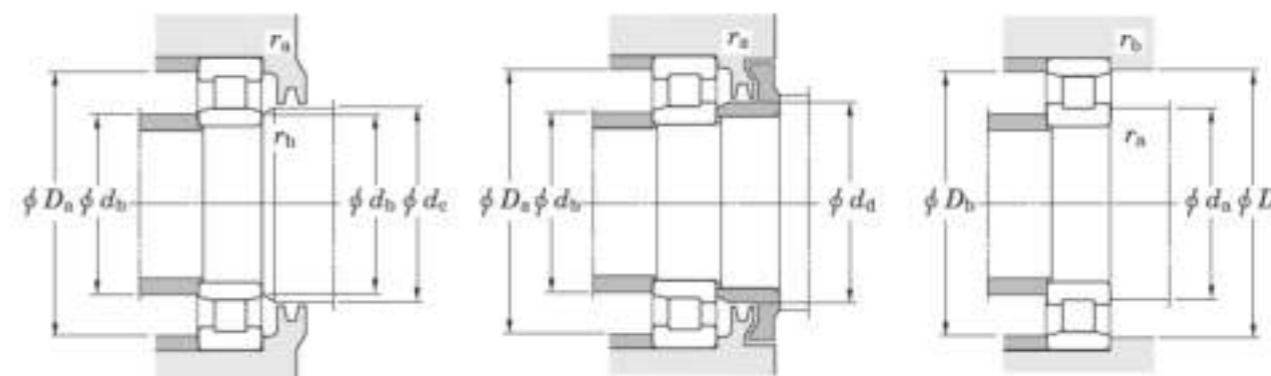
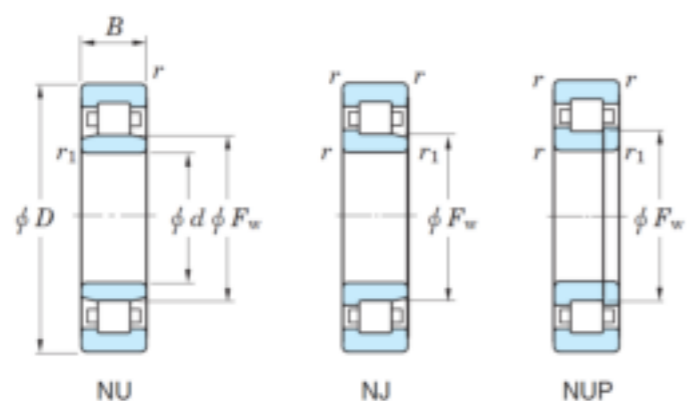

Boundary dimensions						Basic load ratings (kN)		Fatigue load limit(kN)	Limiting speed		Bearing No.			Mounting dimensions							Mass NU (N) (kg)		
d	D	B	r min.	r1 min.	Fw	Cr	Cor	Cu	Grease lub	Oil lub.	NU	NJ	NUP	da	db		dc	dd	Da	ra		rb	
														min.	min.	max.	min.	min.	max.	max.		max.	
45	75	16	1	0.6	52.5	38.9	33.8	4.3	9 200	11 000	NU1009	-	NUP1009	50	49	52	54		70	1	0.6	0.289	
	85	19	1.1	1.1	54.5	78.9	66.4	9.05	7 600	9 200	NU209R	NJ209R	NUP209R	51.5	51.5	54	57	61	78.5	1	1	0.439	
	85	19	-	-	-	-	-	-	-	-	NU209	NJ209	NUP209	-	-	-	-	-	-	-	-	-	
	85	23	1.1	1.1	55	76.6	67.8	9.6	6 900	9 200	NU2209	NJ2209	NUP2209	51.5	51.5	54	57	61	78.5	1	1	0.536	
	85	23	-	-	-	-	-	-	-	-	NU2209E-TVPC3	-	NUP2209E-TVP	-	-	-	-	-	-	-	-	-	
	100	36	1.5	1.5	58.5	124	113	14.3	5 500	8 300	NU2309	NJ2309	NUP2309	53	53	57	60	66	92	1.5	1.5	1.25	
	100	25	-	-	-	-	-	-	-	-	NU309	NJ309	NUP309	-	-	-	-	-	-	-	-	-	-
	100	25	1.5	1.5	58.5	122	98.3	13.5	6100	8200	NU309R	NJ309R	NUP309R	53	53	57	60	66	92	1.5	1.5	0.909	
50	80	16	1	0.6	57.5	42.2	36.8	4.8	8 400	9 900	NU1010	-	NUP1010	55	54	57	59		75	1	0.6	0.306	
	90	20	1.1	1.1	59.5	82.5	71.9	9.85	7 100	8 500	NU210R	NJ210R	NUP210R	56.5	56.5	58	62	67	83.5	1	1	0.497	
	90	20	-	-	-	-	-	-	-	-	NU210	NJ210	NUP210	-	-	-	-	-	-	-	-	-	
	90	23	1.1	1.1	60.4	80.3	73.6	10.4	6400	8500	NU2210	NJ2210	NUP2210	56.5	56.5	58	62	67	83.5	1	1	0.580	
	110	40	2	2	65	151	142	20.1	5 000	7 500	NU2310	NJ2310	NUP2310	59	59	63	67	73	101	2	2	1.69	
	110	27	-	-	-	-	-	-	-	-	NU310	NJ310	NUP310	-	-	-	-	-	-	-	-	-	-
	110	27	2	2	65	138	113	16	5500	7400	NU310R	NJ310R	NUP310R	59	59	63	67	73	101	2	2	1.15	
55	90	18	1.1	1	64.5	47.1	43.8	5.75	7 600	8 900	NU1011	-	NUP1011	61.5	60	63	66		83.5	1	1	0.445	
	100	21	1.5	1.1	66	108	98.7	14.2	6 400	7 700	NU211R	NJ211R	NUP211R	63	61.5	65	68	73	92	1.5	1	0.65	
	100	21	1.5	1.5	-	-	-	-	-	-	NU211	NJ211	NUP211	-	-	-	-	-	-	-	-	-	
	100	25	1.5	1.1	66.5	94.2	87.2	11.6	5 800	7 700	NU2211	NJ2211	NUP2211	63	61.5	65	68	73	92	1.5	1	0.78	
	120	43	2	2	70.5	185	162	24.6	4 500	6 800	NU2311	NJ2311	NUP2311	64	64	69	72	80	111	2	2	2.1	
	120	29	-	-	-	-	-	-	-	-	NU311	NJ311	NUP311	-	-	-	-	-	-	-	-	-	-
	120	29	2	2	70.5	172	143	19.8	5100	6700	NU311R	NJ311R	NUP311R	64	64	69	72	80	111	2	2	1.50	
60	95	18	1.1	1	69.5	53	50	6.75	7 000	8 300	NU1012	-	NUP1012	66.5	65	68	71		88.5	1	1	0.477	
	110	22	1.5	1.5	72	122	107	15.7	5 800	6 900	NU212R	NJ212R	NUP212R	68	68	71	75	80	102	1.5	1.5	0.83	
	110	22	1.5	1.5	-	-	-	-	-	-	NU212	NJ212	-	-	-	-	-	-	-	-	-	-	
	110	28	1.5	1.5	73.5	120	123	15.3	5 200	7 000	NU2212	NJ2212	NUP2212	68	68	71	75	80	102	1.5	1.5	1.07	
	110	28	1.5	1.5	-	-	-	-	-	-	-	-	NUP2212E-TVP	-	-	-	-	-	-	-	-	-	
	130	46	2.1	2.1	77	211	188	29.4	4 200	6 300	NU2312	NJ2312	NUP2312	71	71	75	79	86	119	2	2	2.69	
	130	31	2.1	2.1	-	-	-	-	-	-	NU312	NJ312	NUP312	-	-	-	-	-	-	-	-	-	-
	130	31	2.1	2.1	77	187	157	22.1	4600	6200	NU312R	NJ312R	NUP312R	71	71	75	79	86	119	2	2	1.87	

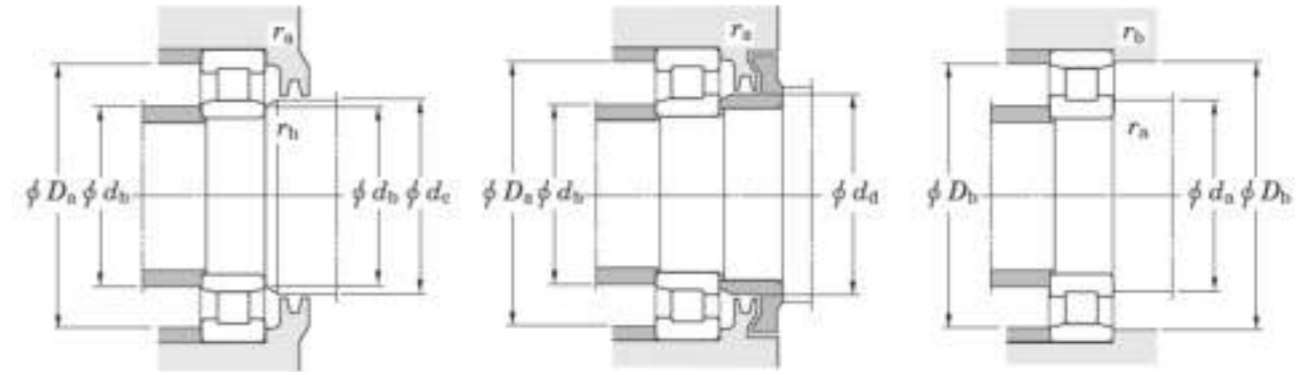
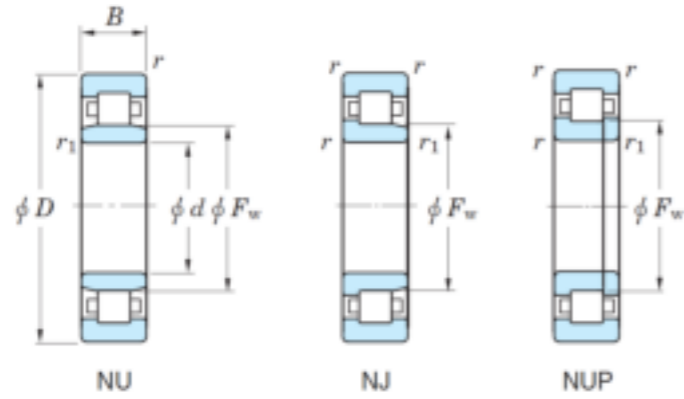

Boundary dimensions						Basic load ratings (kN)		Fatigue load limit(kN)	Limiting speed		Bearing No.			Mounting dimensions						Mass NU (N) (kg)		
d	D	B	r min.	r1 min.	Fw	Cr	Cor	Cu	Grease lub	Oil lub.	NU	NJ	NUP	da	db		dc	dd	Da		ra	rb
														min.	min.	max.	min.	min.	max.		max.	max.
65	100	18	1.1	1	74.5	54.4	52.9	7.15	6 600	7 800	NU1013	-	NUP1013	71.5	70	73	76	-	93.5	1	1	0.506
	120	23	1.5	1.5	78.5	134	119	16.1	5 300	6 400	NU213R	NJ213R	NUP213R	73	73	77	81	87	112	1.5	1.5	1.05
	120	23	-	-	-	-	-	-	-	-	NU213	NJ213	-	-	-	-	-	-	-	-	-	-
	120	31	1.5	1.5	79.6	150	149	20.6	4 800	6 400	NU2213	NJ2213	NUP2213	73	73	77	81	87	112	1.5	1.5	1.43
	140	48	2.1	2.1	83.5	235	212	32.9	3 900	5 800	NU2313	NJ2313	NUP2313	76	76	81	85	93	129	2	2	3.25
	140	33	-	-	-	-	-	-	-	-	-	NU313	NJ313	NUP313	-	-	-	-	-	-	-	-
70	140	33	2.1	2.1	82.5	226	191	29.8	4 300	5 700	NU313R	NJ313R	NUP313R	76	76	81	85	93	129	2	2	2.31
	110	20	1.1	1	80	72.9	70.4	10.1	6 100	7 200	NU1014	-	NUP1014	76.5	75	78	82	-	103.5	1	1	0.702
	125	24	1.5	1.5	83.5	148	137	19	5 000	6 000	NU214R	NJ214R	NUP214R	78	78	82	86	92	117	1.5	1.5	1.16
	125	24	-	-	-	-	-	-	-	-	NU214	NJ214	-	-	-	-	-	-	-	-	-	-
	125	31	1.5	1.5	84.5	149	151	20.8	4 600	6 100	NU2214	NJ2214	NUP2214	78	78	82	86	92	117	1.5	1.5	1.52
	150	51	2.1	2.1	89	342	323	47.1	3 600	5 300	NU2314R	NJ2314R	NUP2314R	81	81	87	92	100	139	2	2	4.08
75	150	35	-	-	-	-	-	-	-	-	NU314	NJ314	NUP314	-	-	-	-	-	-	-	-	-
	150	35	2.1	2.1	89	256	222	33.4	4 000	5 300	NU314R	NJ314R	NUP314R	81	81	87	92	100	139	2	2	2.81
	115	20	1.1	1	85	80	78.1	10.2	5 700	6 800	NU1015	-	NUP1015	81.5	80	83	87	-	108.5	1	1	0.735
	130	25	1.5	1.5	88.5	163	156	21.9	4 800	5 700	NU215R	NJ215R	NUP215R	83	83	87	90	96	122	1.5	1.5	1.29
	130	25	-	-	-	-	-	-	-	-	NU215	NJ215	-	-	-	-	-	-	-	-	-	-
	130	31	1.5	1.5	88.5	162	172	22.3	4 300	5 800	NU2215	NJ2215	NUP2215	83	83	87	90	96	122	1.5	1.5	1.57
80	160	65	-	-	-	-	-	-	-	-	NU2315	-	-	-	-	-	-	-	-	-	-	-
	160	55	2.1	2.1	95	412	395	57.3	3 300	5 000	NU2315R	NJ2315R	NUP2315R	86	86	93	97	106	149	2	2	5.00
	160	37	-	-	-	-	-	-	-	-	NU315	NJ315	NUP315	-	-	-	-	-	-	-	-	-
	160	37	2.1	2.1	95	300	263	39.9	3 700	5 000	NU315R	NJ315R	NUP315R	86	86	93	97	106	149	2	2	3.37
	140	26	2	2	95.3	174	167	23	4 400	5 300	NU216R	NJ216R	NUP216R	89	89	94	97	104	131	2	2	1.56
	140	26	-	-	-	-	-	-	-	-	NU216	NJ216	-	-	-	-	-	-	-	-	-	-
80	140	33	2	2	95.3	184	186	27.8	4 000	5 400	NU2216	NJ2216	NUP2216	89	89	94	97	104	131	2	2	1.96
	170	58	2.1	2.1	101	343	332	46.9	3 100	4 700	NU2316	NJ2316	NUP2316	91	91	99	105	114	159	2	2	5.83
	170	58	-	-	-	-	-	-	-	-	NU316	NJ316	-	-	-	-	-	-	-	-	-	-
	170	39	2.1	2.1	101	320	282	42.1	3 500	4 700	NU316R	NJ316R	NUP316R	91	91	99	105	114	159	2	2	4.00

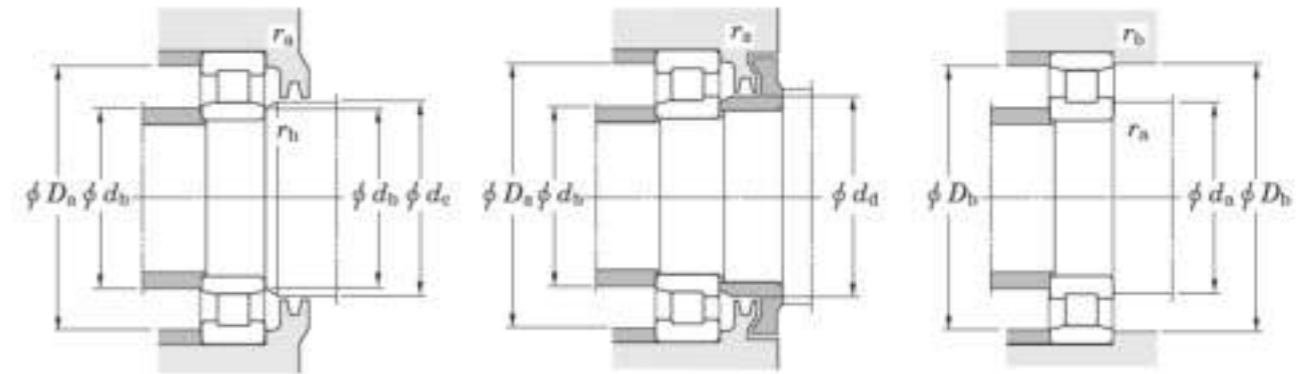
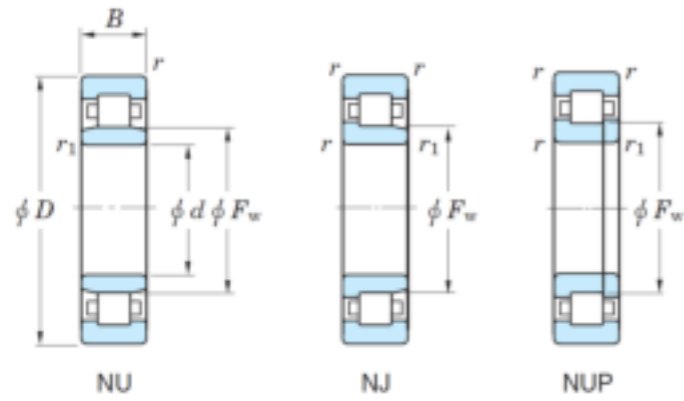

Boundary dimensions						Basic load ratings (kN)			Fatigue load limit(kN)	Limiting speed		Bearing No.			Mounting dimensions							Mass NU (N) (kg)
d	D	B	r min.	r1 min.	Fw	Cr	Cor	Cu	Grease lub	Oil lub.	NU	NJ	NUP	da	db		dc	dd	Da	ra	rb	
														min.	min.	max.	min.	min.	max.	max.	max.	
85	150	28	2	2	100.5	209	199	26.3	4200	5000	NU217R	NJ217R	NUP217R	94	94	99	104	110	141	2	2	1.94
	150	28	-	-	-	-	-	-	-	-	NU217	NJ217	-	-	-	-	-	-	-	-	-	-
	150	36	2	2	101.8	212	218	31.6	3800	5000	NU2217	NJ2217	NUP2217	94	94	99	104	110	141	2	2	2.5
	180	60	3	3	108	394	382	54.2	3000	4500	NU2317	NJ2317	NUP2317	98	98	106	110	119	167	2.5	2.5	6.62
	180	41	-	-	-	-	-	-	-	-	NU317	NJ317	-	-	-	-	-	-	-	-	-	-
	180	41	3	3	108	364	330	48.3	3300	4400	NU317R	NJ317R	NUP317R	98	98	106	110	119	167	2.5	2.5	4.80
90	160	30	2	2	107	227	217	28.7	3900	4700	NU218R	NJ218R	NUP218R	99	99	105	109	116	151	2	2	2.38
	160	30	-	-	-	-	-	-	-	-	NU218	NJ218	-	-	-	-	-	-	-	-	-	-
	160	40	2	2	107	259	265	38.9	3500	4700	NU2218	NJ2218	NUP2218	99	99	105	109	116	151	2	2	3.1
	190	64	3	3	115	408	395	55.5	2800	4200	NU2318	NJ2318	NUP2318	103	103	111	117	127	177	2.5	2.5	7.90
95	170	32	2.1	2.1	112.5	275	265	38.3	3700	4400	NU219R	-	-	106	106	111	116	123	159	2	2	2.92
	170	32	-	-	-	-	-	-	-	-	NU219	-	-	-	-	-	-	-	-	-	-	-
100	180	46	2.1	2.1	119	417	444	60.7	3100	4200	NU220R	-	-	-	-	-	-	-	-	-	-	-
	180	46	-	-	-	-	-	-	-	-	NU220	-	-	111	111	117	122	130	169	2	2	4.82
110	200	38	-	-	-	-	-	-	-	-	NU222	-	-	-	-	-	-	-	-	-	-	-

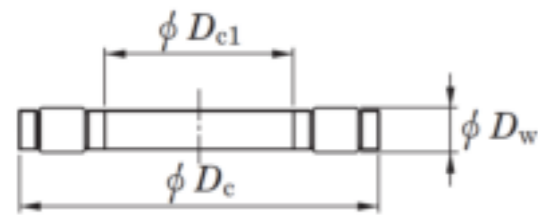

K.811, K.812

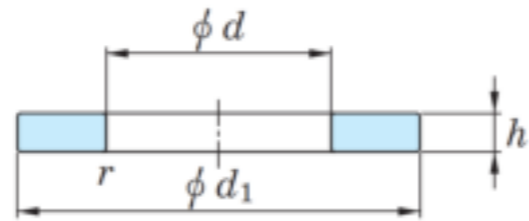

WS.811, WS.812

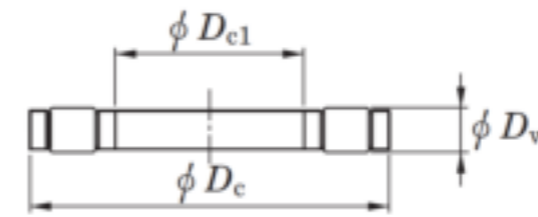

K.811, K.812

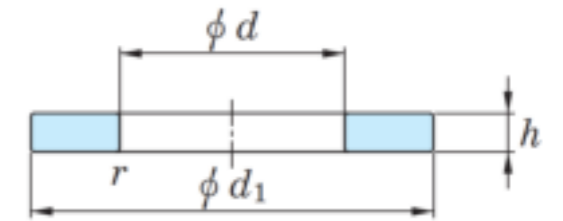

WS.811, WS.812

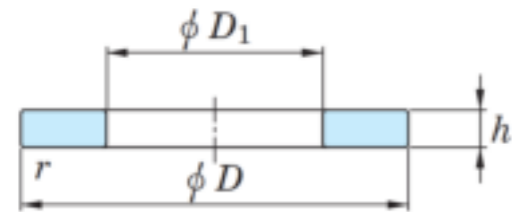

GS.811, GS.812

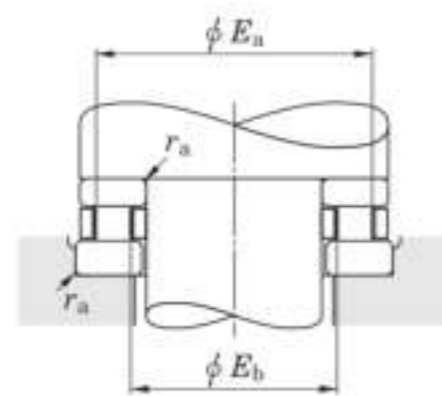

GS.811, GS.812

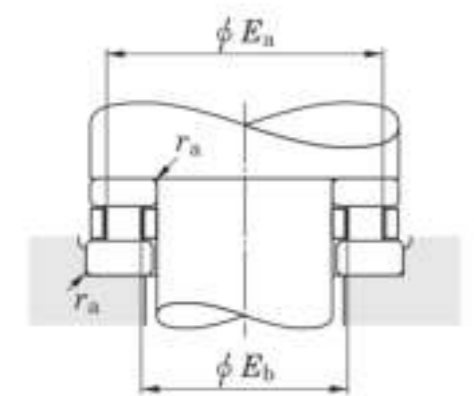

Shaft Dia	Assembly Dimensions (mm)								Load Ratings			Fatigue Load Limit Cu	Speed Rating Oil	Approx Weight (kg)	Washer Dimensions (mm)			h		rs min	Washer Designation		Approx Weight (kg)	Shaft Dia (mm)	
	Dc1	Dc	Dw	T	Eb max	Ea min	ras max ra max	Assembly Designation	Dynamic	Static	C				Co	d	D1	D,d1	Max		Min	Shaft Piloted			Housing Piloted
									C	Co															
40	40	60	6	-	44	56	0.6	K.81108	44.2	126	12	5 300	0.044	40	42	60	3.5	3.34	0.6	WS.81108	GS.81108	0.043	40		
55	55	78	6	16	60	73	0.6	K.81111	60.3	207	19.8	4 000	0.066	55	57	78	5	4.81	0.6	WS.81111	GS.81111	0.094	55		
70	70	95	7.5	18	75	90	1	K.81114	92.1	328	35.5	3 200	0.056	70	72	95	5.25	5.06	1	WS.81114	GS.81114	0.133	70		

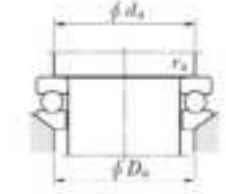
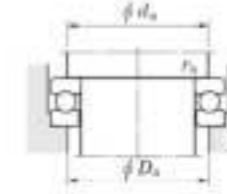
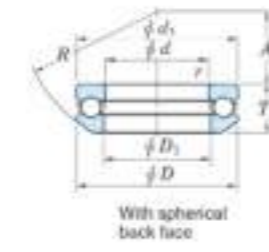
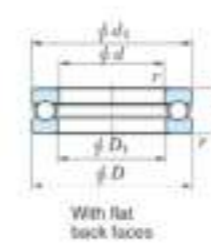
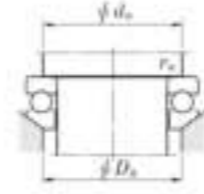
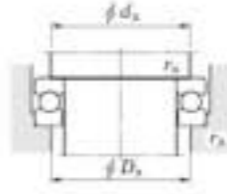
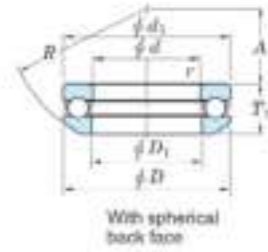
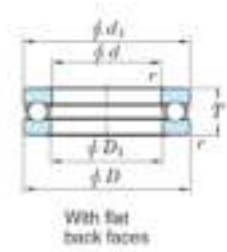

d	Boundary dimensions(mm)					Basic load ratings(kN)		Fatigue load limit(kN)	Limiting speeds		Bearing No.			Dimensions						Mounting dimensions(mm)			Mass(kg)		
	D	T	T1	T2	r min.	Cr	Cor	Cu	Grease lub.	Oil lub.	With flat back faces	With spherical back face*		d1	D1 min.	D2	D3	A	R	C	da min.	Da max.	ra max.	With flat back faces	With spherical back face
85	110	19	-	-	1	57.4	150	6.8	2100	3200	51117	-	110	87	-	-	-	-	-	100	95	1	0.46	-	-
	125	31	33.1	37	1	119	264	11.6	1500	2300	51217	53217	125	88	105	130	52	100	11	109	101	1	1.29	1.28	1.57
	150	49	53.1	58	1.5	232	419	17.5	1100	1700	51317	53317	150	88	115	155	43	112	17.5	124	111	1.5	3.66	3.63	4.44
90	120	22	-	-	1	74.6	190	8.4	1900	2900	51118	-	120	92	-	-	-	-	-	108	102	1	0.68	-	-
	135	35	38.5	42	1.1	146	326	13.9	1400	2100	51218	53218	135	93	110	140	45	100	13.5	117	108	1	1.77	1.77	2.19
	155	50	54.6	59	1.5	242	454	18.5	1000	1600	51318	53318	155	93	120	160	40	112	18	129	116	1.5	3.88	3.87	4.71
100	135	25	-	-	1	106	268	11.2	1600	2500	51120	-	135	102	-	-	-	-	-	121	114	1	0.99	-	-
	150	38	40.9	45	1.1	183	410	16.6	1200	1900	51220	53220	150	103	125	155	52	112	14	130	120	1	2.36	2.34	2.84
110	145	25	-	-	1	109	288	11.5	1600	2400	51122	-	145	112	-	-	-	-	-	131	124	1	1.08	-	-
120	155	25	-	-	1	111	305	11.9	1500	2300	51124	-	155	122	-	-	-	-	-	141	134	1	1.16	-	-
130	170	30	-	-	1	130	350	13	1300	2000	51126	-	170	132	-	-	-	-	-	154	146	1	1.87	-	-
140	180	31	-	-	1	133	375	13.5	1200	1900	51128	-	178	142	-	-	-	-	-	164	156	1	2.02	-	-

* Not a stocked range although available on request.

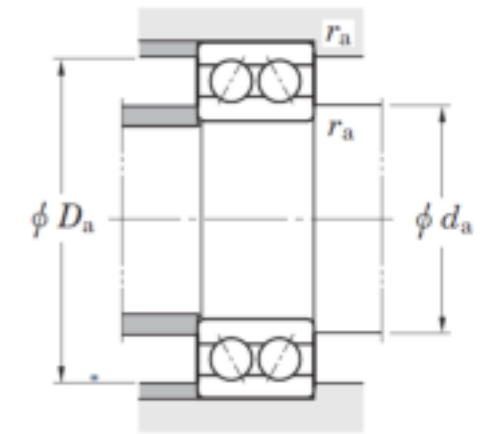
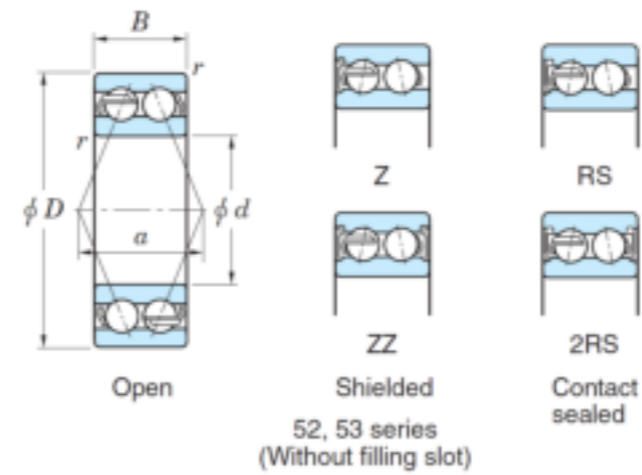
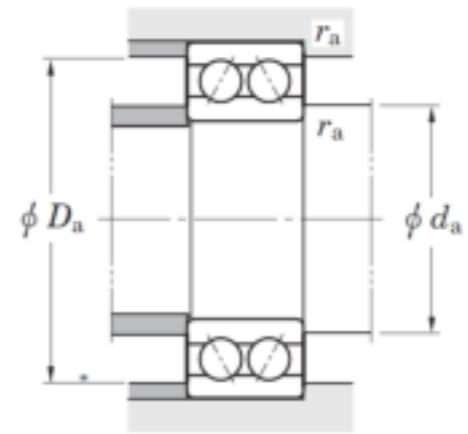
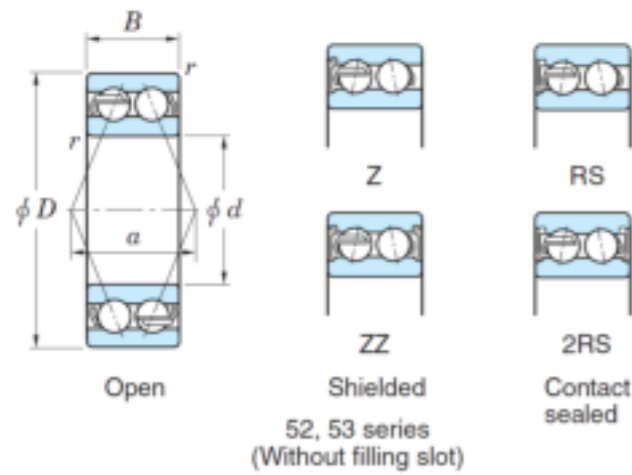

Boundary dimensions(mm)				Basic load ratings (kN)				Fatigue load limits (kN)		Limiting speeds (min ⁻¹)			Bearing No.			Load center spread (mm) Open a	Mounting dimensions (mm)			Mass (kg)	
d	D	B	r min	Open		(ZZ, 2RS)		Cu		Grease lub.		Oil lub.	Open*	ZZ	2RS		da		Da		ra
				Cr	Cor	Cr	Cor	Open	(ZZ, 2RS)	(Open, Z, ZZ)	(RS, 2RS)	(Open, Z)					min.	max.	max.		max.
20	52	22.2	1.1	30.9	15	24.7	12.8	0.78	0.66	8300	8300	11000	5304	5304-ZZ	5304-2RS	25.9	27	28.3	45	1	0.23
25	62	25.4	1.1	40.9	20.8	34.3	18.5	1.05	0.96	6900	6900	9200	5305	5305-ZZ	5305-2RS	31.1	32	33.4	55	1	0.34
30	72	30.2	1.1	51.2	28.5	42.9	25.2	1.45	1.3	5800	5800	7700	5306	5306-ZZ	5306-2RS	36.2	37	41.3	65	1	0.51
35	80	34.9	1.5	64	36.2	57.6	32.8	1.85	1.7	5100	5100	68000	5307	5307-ZZ	5307-2RS	41	43.5	45.5	71.5	1.5	0.79
40	90	36.5	1.5	78.3	45.4	64.3	37.8	2.35	1.95	4600	4600	6100	5308	5308-ZZ	5308-2RS	44.9	48.5	52.1	81.5	1.5	1.05
45	100	39.7	1.5	93.8	55.7	86.1	51.4	2.9	2.65	4100	4100	5500	5309	5309-ZZ	5309-2RS	51	53.5	58.2	91.5	1.5	1.42
50	110	44.4	2	111	67.0	102	62.2	3.45	3.2	3600	3600	4800	5310	5310-ZZ	5310-2RS	56.6	60	64.4	100	2	1.93
55	120	49.2	2	138	85.1	120	74.3	4.4	3.85	3300	3300	4500	5311	5311-ZZ	5311-2RS	61.6	65	71.8	110	2	2.3
60	130	54	2.1	157	98.7	138	87.1	5.1	4.5	3100	3100	4100	5312	5312-ZZ	5312-2RS	67.2	72	79.2	118	2	3.16
65	140	58.7	2.1	178	113	178	113	5.75	5.75	2900	2900	3900	5313	5313-ZZ	5313-2RS	70.9	77	85.9	128	2	3.91
70	150	63.5	2.1	200	129	200	129	6.35	6.35	2700	2700	3600	5314	5314-ZZ	5314-2RS	76	82	92.9	138	2	4.89
75	160	68.3	2.1	218	147	218	147	6.95	6.95	2500	2500	3300	5315	5315-ZZ	5315-2RS	81.5	87	99.6	148	2	5.97

* Not a stocked range although available on request.

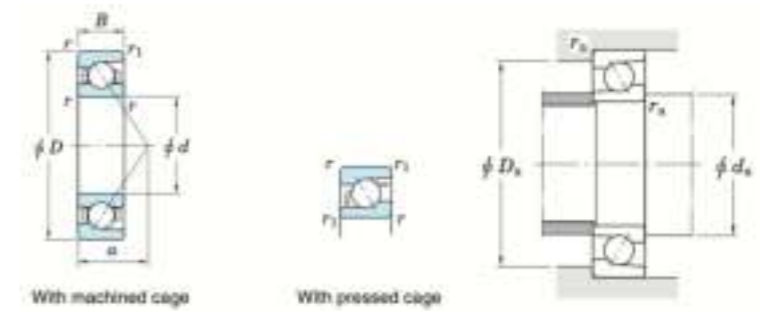
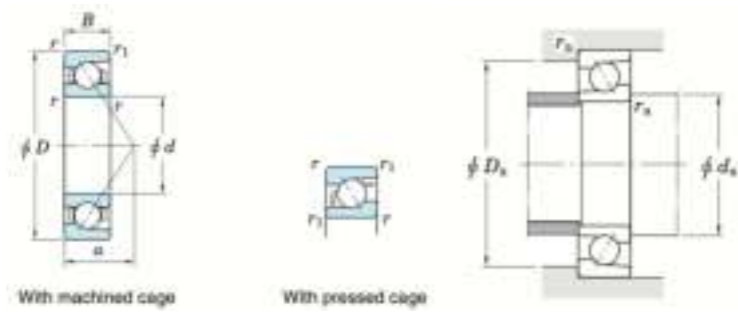

d	Boundary dimensions(mm)				Basic load ratings (kN)				Fatigue load limits (kN)		Limiting speeds	Bearing No.	Load center (mm)	Mounting dimensions (mm)			Mass(kg)		
	D	B	r min	r1 min	With machined cage		With pressed cage		Cu					Grease lub.	Oil lub.	da min.		Da max.	ra max.
	Cr	COr	Cr	COr	With machined cage	With pressed cage													
10	26	8	0.3	0.15	6.25	2.35	-	-	0.12	-	34 000	42 000	7000	9.1	12.5	23.5	0.3	0.021	
12	28	8	0.3	0.15	6.75	2.75	-	-	0.14	-	29 000	37 000	7001	9.9	14.5	25.5	0.3	0.024	
	32	10	0.6	0.3	8.65	3.4	9.3	3.75	0.24	0.27	20 000	27 000	7201B	14.2	16.5	27.5	0.6	0.038	
15	32	9	0.3	0.15	7.65	3.45	-	-	0.18	-	26 000	32 000	7002	11.3	17.5	29.5	0.3	0.035	
	35	11	0.6	0.3	9.3	3.95	9.3	3.95	0.26	0.26	18 000	24 000	7202B	16.2	19.5	30.5	0.6	0.048	
	42	13	1	0.6	15.7	6.45	16.8	7.2	0.49	0.55	20 000	25 000	7302B	15	20.5	36.5	1	0.088	
17	35	10	0.3	0.15	8.4	4.15	-	-	0.21	-	23 000	28 000	7003	12.7	19.5	32.5	0.3	0.045	
	40	12	0.6	0.3	11.7	5.05	11.7	5.05	0.33	0.33	16 000	21 000	7203B	18.2	21.5	35.5	0.6	0.07	
	47	14	1	0.6	17.3	7.3	18.5	8.1	0.51	0.57	14 000	18 000	7303B	20.8	22.5	41.5	1	0.12	
20	42	12	0.6	0.3	12.9	6.1	-	-	0.39	-	19 000	24 000	7004	15.1	24.5	37.5	0.6	0.079	
	47	14	1	0.6	16.6	7.7	17.6	8.4	0.5	0.55	13 000	17 000	7204B	21.5	25.5	41.5	1	0.112	
	52	15	1.1	0.6	20.2	8.7	21.7	9.65	0.61	0.68	13 000	17 000	7304B	22.6	27	45	1	0.15	
25	47	12	0.6	0.3	14.1	7.4	-	-	0.45	-	17 000	21 000	7005	16.4	29.5	42.5	0.6	0.091	
	52	15	1	0.6	17.5	8.7	18.4	9.4	0.53	0.58	12 000	15 000	7205B	23.9	30.5	46.5	1	0.135	
	62	17	1.1	0.6	28.6	13.3	30.5	14.6	0.91	1	10 000	14 000	7305B	26.8	32	55	1	0.243	
30	55	13	1	0.6	18.2	10.1	-	-	0.61	-	14 000	18 000	7006	18.8	35.5	49.5	1	0.133	
	62	16	1	0.6	24.3	12.5	25.6	13.6	0.77	0.84	9 600	13 000	7206B	27.6	35.5	56.5	1	0.208	
	72	19	1.1	0.6	34.5	17.4	36.6	19	1.15	1.25	8 700	12 000	7306B	31.3	37	65	1	0.362	
35	62	14	1	0.6	21.9	12.6	-	-	0.74	-	12 000	15 000	7007	21.2	40.5	56.5	1	0.17	
	72	17	1.1	0.6	32	17	33.8	18.5	1.05	1.15	8 300	11 000	7207B	31.4	42	65	1	0.295	
	80	21	1.5	1	40.6	20.2	45.8	24.3	1.3	1.6	7 700	10 000	7307B	35	43.5	71.5	1.5	0.475	
40	68	15	1	0.6	23.4	14.6	-	-	0.83	-	11 000	14 000	7008	23.2	45.5	62.5	1	0.21	
	80	18	1.1	0.6	38.2	21.3	40.2	23	1.3	1.4	7 500	10 000	7208B	34.2	47	73	1	0.382	
	90	23	1.5	1	49.6	25.2	56	30.3	1.65	2	6 900	9 200	7308B	38.8	48.5	81.5	1.5	0.657	
45	75	16	1	0.6	27.8	17.7	-	-	1	-	10 000	12 000	7009	25.3	50.5	69.5	1	0.26	
	85	19	1.1	0.6	42.9	24.3	45.1	26.1	1.5	1.6	7 000	9 400	7209B	36.4	52	78	1	0.43	
	100	25	1.5	1	63.2	34.1	67	37.2	2.2	2.4	6 200	8 200	7309B	43.1	53.5	91.5	1.5	0.875	
50	80	16	1	0.6	29.5	20.1	-	-	1.1	-	9 200	11 000	7010	26.9	55.5	74.5	1	0.29	
	90	20	1.1	0.6	44.6	26.7	46.7	28.6	1.55	1.7	6 400	8 500	7210B	39.6	57	83	1	0.485	
	110	27	2	1	80.5	44.3	85.3	48.3	2.9	3.15	5 500	7 300	7310B	47.9	60	100	2	1.14	
55	90	18	1.1	0.6	38.9	26.3	-	-	1.5	-	8 300	10 000	7011	29.9	62	83	1	0.42	
	100	21	1.5	1	55.1	33.8	57.7	36.2	2	2.15	5 700	7 600	7211B	43.6	63.5	91.5	1.5	0.635	
	120	29	2	1	92.9	52	98.4	56.7	3.4	3.7	5 000	6 700	7311B	51.8	65	110	2	1.45	
60	95	18	1.1	0.6	39.9	28.1	-	-	1.55	-	7 700	9 700	7012	31.4	67	88	1	0.45	
	110	22	1.5	1	66.8	41.6	69.9	44.6	2.45	2.6	5 100	6 900	7212B	47.5	68.5	101.5	1.5	0.82	
	130	31	2.1	1.1	106	60.3	113	65.8	3.95	4.3	4 600	6 200	7312B	55.8	72	118	2	1.81	

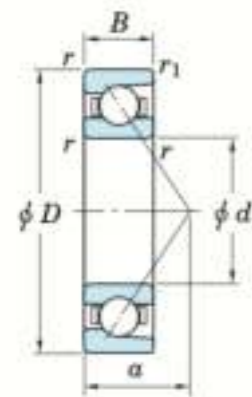

With machined cage



With pressed cage

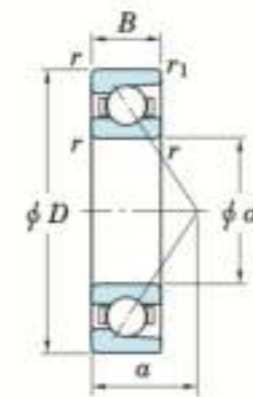
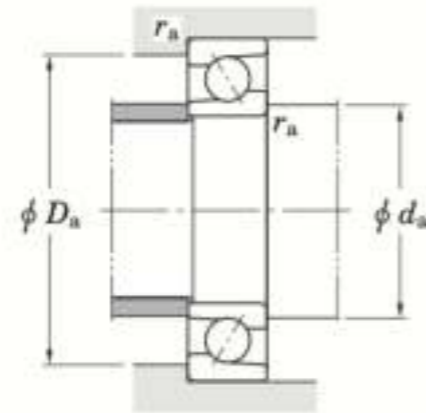

With machined cage

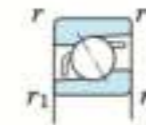

With pressed cage

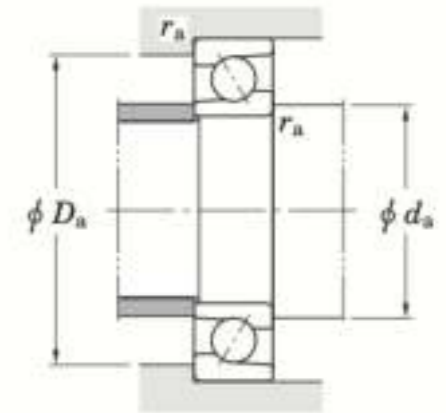

d	Boundary dimensions(mm)				Basic load ratings (kN)				Fatigue load limits (kN)		Limiting speeds		Bearing No.	Load center (mm)	Mounting dimensions (mm)			Mass(kg)
	D	B	r min	r1 min	With machined cage		With pressed cage		Cu		Grease lub.	Oil lub.			da	Da	ra	
	Cr	COr	Cr	COr	With machined cage	With pressed cage	With machined cage	With pressed cage	min.	max.								
65	100	18	1.1	0.6	42.1	31.4	-	-	1.7	-	7 200	9 000	7013	33	72	93	1	0.47
	120	23	1.5	1	76.2	49.3	79.5	52.6	2.9	3.1	4800	6400	7213B	50.3	73.5	111.5	1.5	1.02
70	110	20	1.1	0.6	53.3	39.4	-	-	2.15	-	6 600	8 300	7014	36	77	103	1	0.66
	125	24	1.5	1	79	50.6	86.4	57.8	2.95	3.4	4600	6100	7214B	52.9	78.5	116.5	1.5	1.12
75	130	25	1.5	1	89.6	59.3	93.6	63.3	3.4	3.65	4300	5800	7215B	55.5	83.5	121.5	1.5	1.23
80	140	26	2	1	96.4	65	101	69.3	3.55	3.8	4000	5400	7216B	59.2	90	130	2	1.5
85	150	28	2	1	111	76	116	81.1	4.05	4.35	3800	5000	7217B	63.3	95	140	2	1.87
90	140	24	1.5	1	81.5	63.3	-	-	3.25	-	5 100	6 400	7018	45.2	98.5	131.5	1.5	1.26
100	150	24	1.5	1	85.5	70.6	-	-	3.35	-	4 700	5 900	7020	48.1	108.5	141.5	1.5	1.37

* Not a stocked range although available on request.

Agricultural Planter Bearings

Stocking the bearing DAC164044-2RSLCS16. Please find specification from Automotive Bearings.

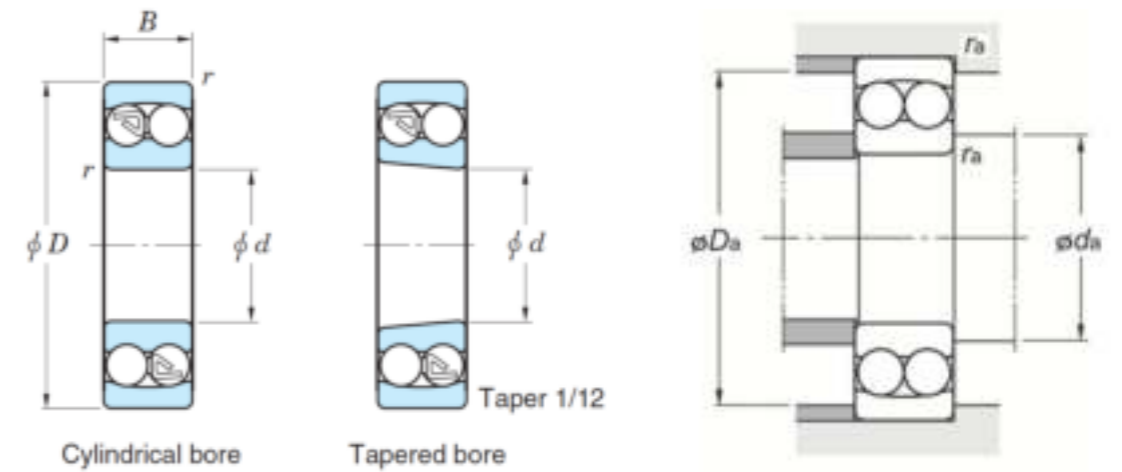
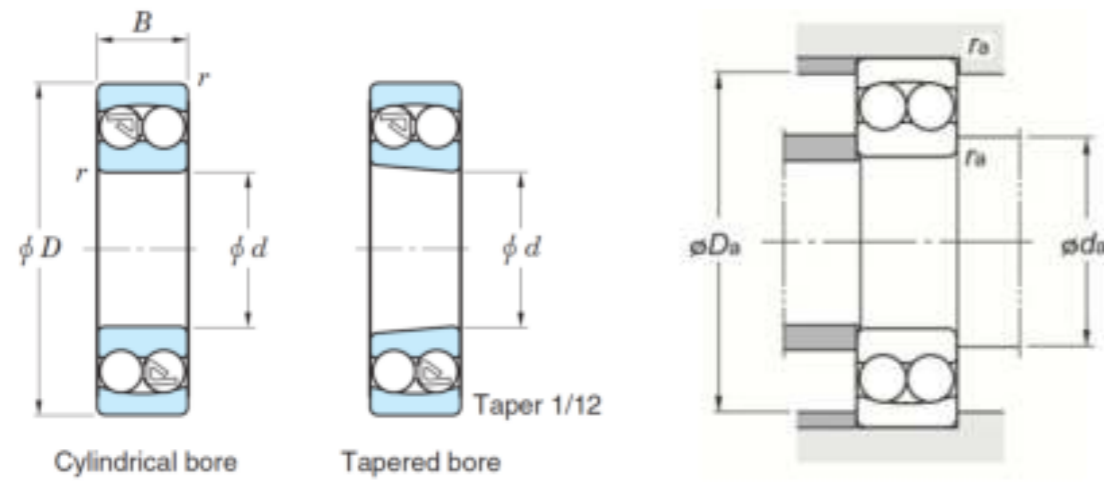

Boundary dimensions(mm)				Basic load ratings(kN)		Fatigue load limit(kN)	Limiting speeds		Bearing No.		Mounting dimensions (mm)			Constant	Axial load factors			Mass(kg)	
d	D	B	r min.	C _r	C _{or}	C _u	Grease lub.	Oil lub.	Cylindrical bore	Tapered bore	da min.	Da max.	ra max.	e	Y1	Y2	Y0	Cylindrical bore	Tapered bore
20	47	18	1	12.6	3.25	0.21	14000	17000	2204	2204K	25	42	1	0.48	1.31	2.02	1.37	0.14	0.136
25	52	15	1	12.1	3.3	0.21	12 000	14 000	1205	1205K	30	47	1	0.28	2.28	3.52	2.39	0.141	0.138
	52	18	1	12.6	3.5	0.22	12000	15000	2205	2205K	30	47	1	0.4	1.58	2.45	1.66	0.163	0.158
30	62	17	1.1	18	5.05	0.32	9 900	12 000	1305	1305K	31.5	55.5	1	0.27	2.31	3.57	2.42	0.257	0.252
	62	16	1	15.6	4.7	0.29	9 900	12 000	1206	1206K	35	57	1	0.25	2.55	3.94	2.67	0.22	0.216
	62	20	1	15.5	4.65	0.29	10 000	12 000	2206	2206K	35	57	1	0.35	1.79	2.77	1.87	0.26	0.254
	72	19	1.1	21.3	6.3	0.4	8 700	11 000	1306	1306K	36.5	65.5	1	0.26	2.4	3.72	2.52	0.387	0.381
35	72	27	1.1	21.3	6.30	0.4	8 000	11 000	2306	2306K	36.5	65.5	1	0.44	1.44	2.23	1.51	0.50	0.492
	72	17	1.1	15.8	5.15	0.32	8 500	10 000	1207	1207K	41.5	65.5	1	0.23	2.71	4.2	2.84	0.323	0.317
	72	23	1.1	21.6	6.65	0.42	8 500	10 000	2207	2207K	41.5	65.5	1	0.37	1.71	2.65	1.79	0.403	0.396
	80	21	1.5	25.1	7.95	0.49	7 600	9 300	1307	1307K	43	72	1.5	0.25	2.48	3.84	2.6	0.51	0.502
40	80	31	1.5	39.5	11.1	0.71	7 100	9 800	2307	2307K	43	72	1.5	0.45	1.39	2.15	1.46	0.675	0.657
	80	18	1.1	19.2	6.5	0.41	7 500	9 200	1208	1208K	46.5	73.5	1	0.22	2.83	4.38	2.97	0.417	0.411
	80	23	1.1	22.4	7.35	0.46	7 600	9 300	2208	2208K	46.5	73.5	1	0.33	1.92	2.96	2.01	0.505	0.494
	90	23	1.5	29.6	9.8	0.61	6 900	8 400	1308	1308K	48	82	1.5	0.25	2.57	3.98	2.69	0.715	0.704
45	90	33	1.5	44.9	13.4	0.85	6 200	8 600	2308	2308K	48	82	1.5	0.43	1.47	2.27	1.54	0.925	0.903
	85	19	1.1	21.8	7.35	0.46	7 000	8 500	1209	1209K	51.5	78.5	1	0.21	2.94	4.56	3.09	0.465	0.459
	85	23	1.1	23.3	8.15	0.51	7 000	8 500	2209	2209K	51.5	78.5	1	0.3	2.09	3.23	2.19	0.545	0.533
	100	25	1.5	38.1	12.9	0.8	6 100	7 500	1309	1309K	53	92	1.5	0.25	2.56	3.95	2.68	0.957	0.942
50	100	36	1.5	54.4	16.6	1.05	5 600	7 700	2309	2309K	53	92	1.5	0.42	1.51	2.33	1.58	1.23	1.2
	90	20	1.1	22.7	8.1	0.51	6 500	7 900	1210	1210K	56.5	83.5	1	0.21	3.07	4.76	3.22	0.525	0.515
	90	23	1.1	23.3	8.5	0.53	6 500	7 900	2210	2210K	56.5	83.5	1	0.27	2.33	3.61	2.45	0.59	0.577
	110	27	2	43.4	14.2	0.89	5 600	6 800	1310	1310K	59	101	2	0.23	2.7	4.17	2.83	1.21	1.19

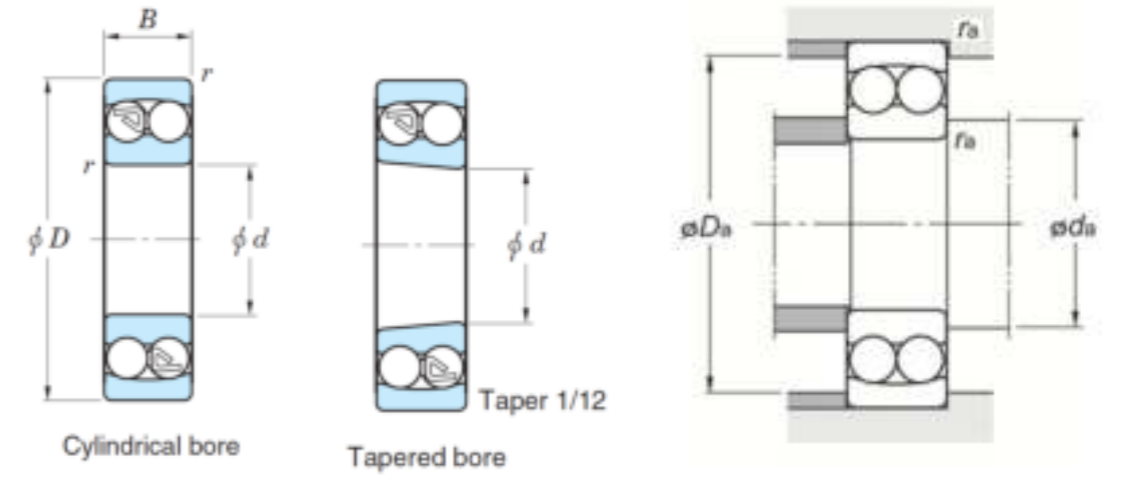
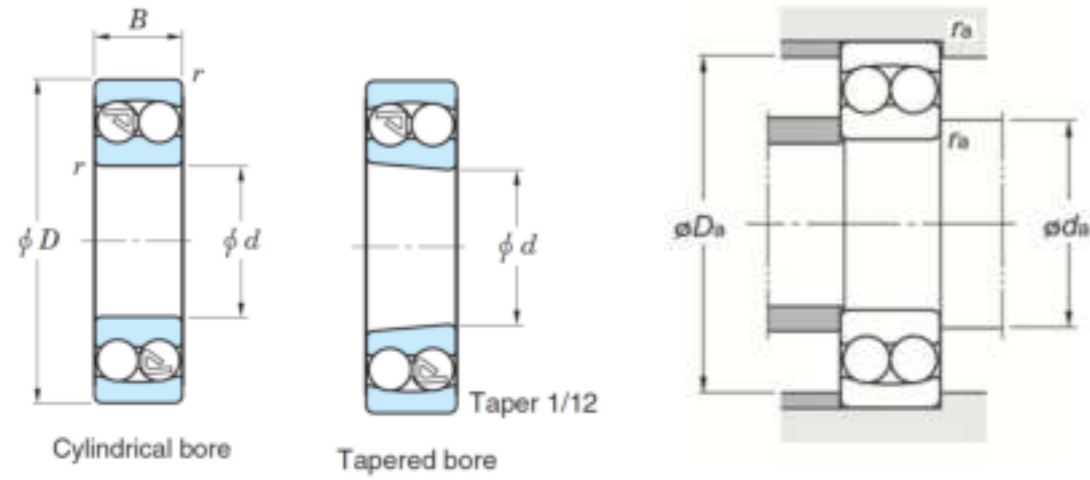

Boundary dimensions(mm)				Basic load ratings(kN)		Fatigue load limit(kN)	Limiting speeds		Bearing No.		Mounting dimensions (mm)			Constant	Axial load factors			Mass(kg)	
d	D	B	r min.	Cr	Cor	Cu	Grease lub.	Oil lub.	Cylindrical bore	Tapered bore	da	Da	ra	e	Y1	Y2	Y0	Cylindrical bore	Tapered bore
											min.	max.	max.						
55	100	21	1.5	26.8	10	0.63	5 800	7 100	1211	1211K	63	92	1.5	0.2	3.19	4.94	3.34	0.705	0.693
	100	25	1.5	26.5	9.95	0.62	5 800	7 100	2211	2211K	63	92	1.5	0.27	2.35	3.64	2.47	0.81	0.792
	120	29	2	51.3	18.1	1.1	5 000	6 200	1311	1311K	64	111	2	0.23	2.7	4.18	2.83	1.58	1.56
60	110	22	1.5	30.2	11.6	0.73	5 200	6 400	1212	1212K	68	102	1.5	0.19	3.37	5.22	3.53	0.9	0.885
	110	28	1.5	34.1	12.5	0.8	5 300	6 500	2212	2212K	68	102	1.5	0.28	2.26	3.49	2.36	1.09	1.07
	130	31	2.1	57.1	20.8	1.3	4 500	5 500	1312	1312K	71	119	2	0.22	2.91	4.5	3.05	1.96	1.93
65	120	23	1.5	31	12.4	0.79	4 800	5 800	1213	1213K	73	112	1.5	0.17	3.67	5.68	3.84	1.15	1.13
	120	31	1.5	43.6	16.4	1.05	4 900	5 900	2213	2213K	73	112	1.5	0.28	2.24	3.47	2.35	1.46	1.43
	140	33	2.1	61.7	22.9	1.4	4 300	5 200	1313	1313K	76	129	2	0.23	2.73	4.23	2.86	2.45	2.41
70	125	24	1.5	34.7	13.7	0.87	4 600	5 700	1214	1214K	78	117	1.5	0.18	3.48	5.38	3.64	1.26	-
75	130	25	1.5	38.8	15.5	0.97	4 300	5 300	1215	1215K	83	122	1.5	0.17	3.6	5.58	3.77	1.36	1.34
	130	31	-	-	-	-	-	-	2215	2215K	-	-	-	-	-	-	-	-	-
80	140	26	2	39.7	16.9	1	4 000	4 900	1216	1216K	89	131	2	0.16	3.9	6.03	4.08	1.67	1.64
	140	33	-	-	-	-	-	-	2216	2216K	-	-	-	-	-	-	-	-	-
85	150	28	2	49.2	20.5	1.2	3 800	4 600	1217	1217K	94	141	2	0.17	3.61	5.59	3.78	2.07	2.04
	150	36	-	-	-	-	-	-	2217	2217K	-	-	-	-	-	-	-	-	-
90	160	30	2	56.8	23.4	1.3	3 500	4 300	1218	1218K	99	151	2	0.17	3.69	5.7	3.86	2.52	2.48
100	180	34	-	-	-	-	-	-	-	1220K	-	-	-	-	-	-	-	-	-

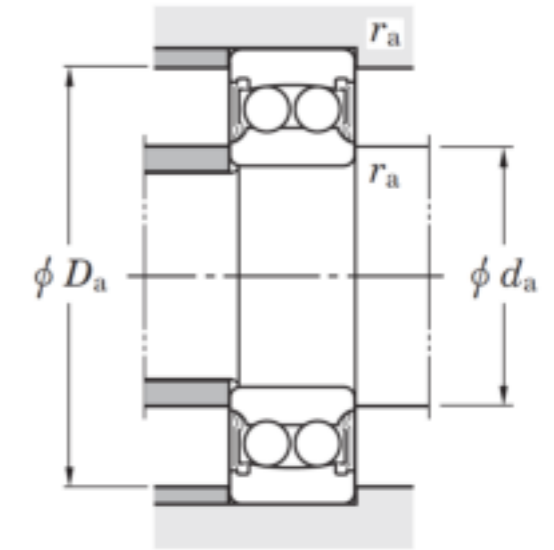
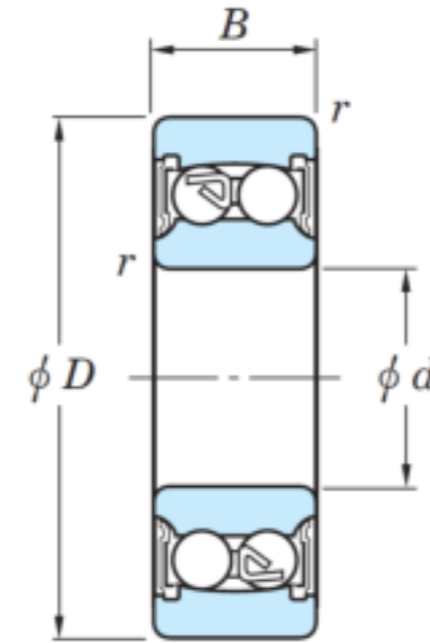
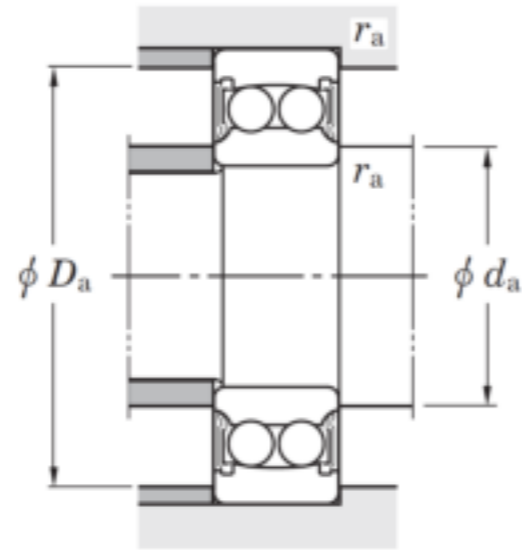
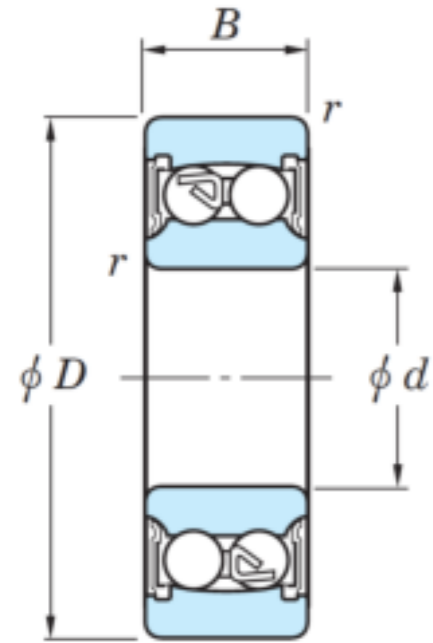

Boundary dimensions (mm)				Basic Load Ratings		Fatigue Load	Limiting Speeds	Bearing no.	Mounting Dimensions (mm)				Constant	Axial load factors			Mass Kg
d	D	B	r min	Cr	Cor	Cu	Grease Lub		da		Da	ra	e	Y1	Y2	Y0	
									min	max	max	max					
25	52	18	1	12.1	3.3	0.21	7900	2205-2RS	29.4	29.4	46	1	0.28	2.28	3.52	2.39	0.163
	62	24	1.1	18	5.05	0.32	6600	2305-2RS	32	33.9	55	1	0.27	2.31	3.57	2.42	0.335
30	62	20	1	15.6	4.7	0.29	6600	2206-2RS	35.5	35.5	56	1	0.25	2.55	3.94	2.67	0.26
	72	27	1.1	21.3	6.3	0.4	5800	2306-2RS	37	37.8	65	1	0.26	2.4	3.72	2.52	0.5
35	72	23	1.1	15.8	5.15	0.32	5700	2207-2RS	40.9	40.9	65	1	0.23	2.71	4.2	2.84	0.403
	80	31	1.5	25.1	7.95	0.49	5 100	2307-2RS	43.5	49.6	71.5	1.5	0.25	2.48	3.84	2.6	0.675
40	80	23	1.1	19.2	6.5	0.41	5000	2208-2RS	47	48.1	73	1	0.22	2.83	4.38	2.97	0.505
	90	33	1.5	38.1	12.9	0.8	4 600	2308-2RS	48.5	49.6	81.5	1.5	0.25	2.57	3.98	2.69	0.925
45	85	23	1.1	21.8	7.35	0.43	4600	2209-2RS	52	52.4	78	1	0.21	2.94	4.56	3.09	0.545
	100	36	1.5	38.1	12.9	0.8	4 100	2309-2RS	53.5	56.6	91.5	1.5	0.25	2.56	3.95	2.68	1.23
50	90	23	1.1	22.7	8.1	0.51	4 300	2210-2RS	56.5	56.5	83	1	0.21	3.07	4.76	3.22	0.59
	110	40	2	43.3	14.2	0.89	3 700	2310-2RS	60	62.5	100	2	0.23	2.7	4.17	2.83	1.64
55	100	25	1.5	26.8	10	0.63	3900	2211-2RS	63.5	63.5	91.5	1.5	0.2	3.19	4.94	3.34	0.81

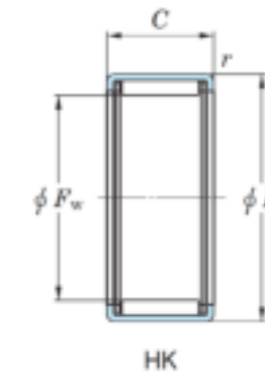
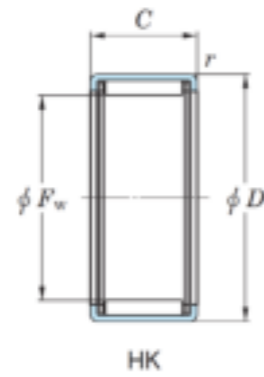

Shaft dia.	Boundary dimensions(mm)				Bearing No.	Basic load ratings(kN)		Fatigue load limit(kN)	Limiting speeds(min-1)		Mass (kg)	Mounting inner ring
	Fw	D	C +0-0.3	r min		Cr	Cor	Cu	Grease lub	Oil lub.		
3	3	6.5	6	0.3	HK0306	1.6	1.14	0.13	30 000	46 000	0.001	-
4	4	8	8	0.4	HK0408	1.88	1.38	0.2	25 000	39 000	0.002	-
5	5	9	9	0.4	HK0509	2.52	2.07	0.32	23 000	36 000	0.002	-
6	6	10	8	0.4	HK0608	2.34	1.95	0.29	22 000	33 000	0.002	-
	6	10	9	0.4	HK0609	3.14	2.85	0.29	22 000	33 000	0.002	-
7	7	11	9	0.4	HK0709	3.23	3.05	0.47	21 000	32 000	0.003	-
8	8	12	8	0.4	HK0808	2.9	2.73	0.4	20 000	31 000	0.003	-
	8	12	10	0.4	HK0810	3.95	4.07	0.6	20 000	31 000	0.004	JR5x8x12
	8	12	10	0.4	HK0810-RS	2.9	2.73	0.4	20000	-	0.004	-
9	9	13	10	0.4	HK0910	4.57	5.07	0.77	19 000	30 000	0.004	JR6x9x12
	9	13	12	0.4	HK0912	5.65	6.65	1.0	1 900	30 000	0.005	JR6x9x12
10	10	14	10	0.4	HK1010	4.78	5.51	0.84	19 000	29 000	0.004	JR7x10x10,5
	10	14	12	0.4	HK1012	5.9	7.23	1.1	19 000	29 000	0.005	JR7x10x12
	10	14	12	0.4	HK1012-RS	4.78	5.51	0.84	19 000	-	0.006	-
	10	14	15	0.4	HK1015	7.49	9.81	1.5	19 000	29 000	0.006	JR7x10x16
12	12	16	10	0.4	HK1210	4.96	6.08	0.89	18 000	28 000	0.006	JR8x12x10.5
	12	18	12	1	HK1212	6.61	7.29	1.1	14 000	22 000	0.01	JR8x12x12.5
	12	18	14	1	HK1214-RS	7.21	8.5	1.3	14 000	21 000	0.014	JR10x14x12
	12	18	16	1	HK1216-2RS	6.87	7.65	1.15	14 000	-	0.0160	-
13	13	19	12	1	HK1312	7.17	8.41	1.3	14 000	-	0.014	JR10x13x12.5
14	14	20	12	1	HK1412	7.21	8.5	1.3	14 000	21 000	0.011	JR10x14x12
	14	20	14	1	HK1414-RS	7.17	8.41	1.3	14 000	-	0.014	JR10x14x16
	14	20	16	1	HK1416-2RS	7.17	8.41	1.3	14 000	-	0.014	JR10x13x12.5
15	15	21	12	1	HK1512	7.49	9.11	1.4	14 000	21 000	0.012	JR12x15x12.5
	15	21	14	1	HK1514-RS	7.87	9.69	1.45	13 000	-	0.016	JR12x15x16.5
	15	21	16	1	HK1516	10.7	14.4	2.2	14 000	21 000	0.018	JR12x15x16.5
	15	21	16	1	HK1516-2RS	7.87	9.69	1.45	13 000	-	0.019	JR12x15x16.5
16	16	22	12	1	HK1612	7.76	9.72	1.5	14 000	21 000	0.012	JR12x16x12
	16	22	14	1	HK1614-RS	7.76	9.76	1.5	12000	-	0.014	JR12x16x16
	16	22	16	1	HK1616	11.1	15.3	2.35	14 000	21 000	0.016	JR12x16x16
	16	22	16	1	HK1616-2RS	7.82	9.76	1.5	12000	-	0.015	JR12x16x20
	16	22	22	1	HK1622	13.4	19.5	2.95	14 000	21 000	0.022	JR12x16x22
17	17	23	12	1	HK1712	8.12	10.4	1.6	13 000	20 000	0.013	-
18	18	24	12	1	HK1812	8.41	11.11	1.7	12 000	18 000	0.015	-
	18	24	14	1	HK1814-RS	8.41	11.10	1.7	11 000	-	0.018	JR15x18x16.5
	18	24	16	1	HK1816	11.6	16.8	2.55	12 000	18 000	0.018	JR15x18x16.5
	18	24	16	1	HK1816-2RS	8.41	11.1	1.7	11000	-	0.017	JR15x118x16.5

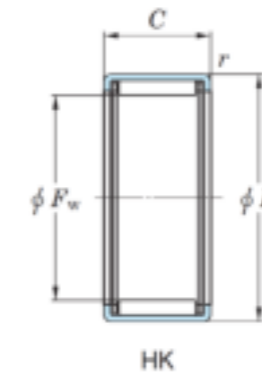
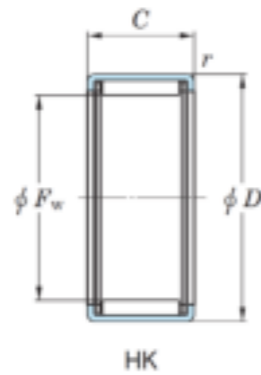

Shaft dia.	Boundary dimensions(mm)				Bearing No.	Basic load ratings(kN)		Fatigue load limit(kN)	Limiting speeds(min-1)		Mass (kg)	Mounting inner ring
	Fw	D	C +0-0.3	r min		Cr	Cor	Cu	Grease lub	Oil lub.		
20	20	26	12	1	HK2012	8.97	12.5	1.9	11 000	16 000	0.015	JR15x20x12
	20	26	16	1	HK2016	12.4	18.9	2.85	11 000	16 000	0.022	JR17x20x16.5
	20	26	16	1	HK2016-2RS	8.97	12.5	1.9	9700	-	0.023	JR17x20x16.5
	20	26	18	1	HK2018-RS	12.4	18.9	2.85	9700	-	0.025	JR17x20x20.5
	20	26	20	1	HK2020	15.9	26.2	3.95	11 000	16 000	0.025	JR17x20x20.5
	20	26	20	1	HK2020-2RS	12.4	18.9	2.85	9700	-	0.028	JR17x20x20.5
	20	26	30	1	HK2030	21.2	37.8	5.75	11 000	16 000	0.041	JR17x20x30.5
22	22	28	12	1	HK2212	9.81	14.5	2.2	9 600	15 000	0.015	JR17x22x13
	22	28	16	1	HK2216	13.1	20.9	3.2	9 600	15 000	0.022	JR17x22x16
	22	28	16	1	HK2216-2RS	9.81	14.5	2.2	8 800	-	0.025	-
	22	28	18	1	HK2218-RS	13.1	20.9	3.2	8 800	-	0.027	JR17x22x23
	22	28	20	1	HK2220	15.3	25.5	4	9 600	15 000	0.026	JR17x22x2
	22	28	20	1	HK2220-2RS	13.1	20.9	3.2	8800	-	0.026	JR17x22x33
25	25	32	12	1	HK2512	10.9	14.7	2.25	8 500	13 000	0.021	-
	25	32	16	1	HK2516	15.6	23.5	3.55	8 500	13 000	0.028	JR20x25x17
	25	32	16	1	HK2516-2RS	11.1	15.1	2.3	7800	-	0.03	JR20x25x17
	25	32	18	1	HK2518-RS	15.6	24.6	3.8	7800	-	0.034	JR20x25x20.5
	25	32	20	1	HK2520	20.6	33.4	5.3	8 500	13 000	0.04	JR20x25x20.5
	25	32	20	1	HK2520-2RS	16.2	24.6	3.8	7800	-	0.033	JR20x25x20.5
	25	32	22	1	HK2522-RS	20.6	33.4	5.3	7800	-	0.042	JR20x25x26
	25	32	24	1	HK2524-2RS	20.6	33.4	5.3	7 800	-	0.047	JR20x25x26
	25	32	26	1	HK2526	25.7	44.4	6.95	8 500	13 000	0.046	JR20x25x26.5
25	32	38	1	HK2538	35.3	66.9	10.6	8 500	13 000	0.068	JR20x25x38.5	
28	28	35	16	1	HK2816	15.9	24.9	3.85	7 500	12 000	0.032	JR22x28x17
	28	35	20	1	HK2820	20.9	35.3	5.6	7 500	12 000	0.04	JR22x28x20.5
	28	35	20	1	HK2820-2RS	15.9	24.9	3.85	6900	-	0.042	JR22x28x20.5
30	30	37	12	1	HK3012	22.4	39.6	6.25	7 000	11 000	0.042	JR25x30x20.5
	30	37	16	1	HK3016	16.8	27.3	4.2	7 000	11 000	0.032	JR25x30x17
	30	37	16	1	HK3016-2RS	11.6	16.8	2.55	6 500	-	0.03	JR25x30x17
	30	37	18	1	HK3018-2RS	16.8	27.3	4.2	6 500	-	0.042	JR25x30x20.5
	30	37	20	1	HK3020	22.4	39.6	6.25	7 000	11 000	0.042	JR25x30x20.5
	30	37	20	1	HK3020-2RS	16.8	27.3	4.2	6 500	-	0.04	JR25x30x20.5
	30	37	24	1	HK3024-2RS	22.4	39.6	6.25	6 500	-	0.057	JR2530x26
	30	37	26	1	HK3026	27.4	51.2	7.95	7 000	11 000	0.054	JR25x30x26.5
30	37	38	1	HK3038	38.4	79.2	12.5	7 000	11 000	0.075	JR25x30x38.5	
35	35	42	12	1	HK3512	13.0	20.6	2.9	5 900	9 100	0.028	-
	35	42	16	1	HK3516	17.4	29.9	4.6	5 900	9 100	0.037	JR30x35x17
	35	42	16	1	HK3516-2RS	13.4	21.4	3.25	5500	-	0.047	JR30x35x17
	35	42	20	1	HK3520	24.5	46.8	7.4	5 900	9 100	0.049	JR30x35x20.5
	35	42	20	1	HK3520-2RS	17.4	29.9	4.6	5500	-	0.044	JR30x35x20.5

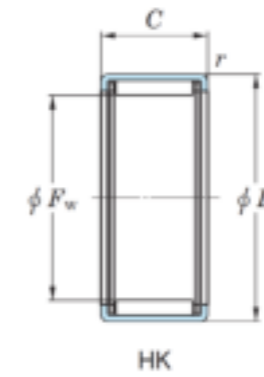
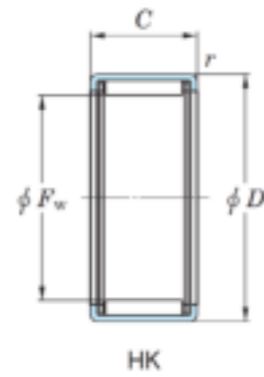

Shaft dia.	Boundary dimensions(mm)				Bearing No.	Basic load ratings(kN)		Fatigue load limit(kN)	Limiting speeds(min-1)		Mass (kg)	Mounting inner ring
	Fw	D	C +0-0.3	r min		Cr	CO _r	Cu	Grease lub	Oil lub.		
40	40	47	12	1	HK4012	14.7	25.3	3.4	5 200	7 900	0.033	-
	40	47	16	1	HK4016	18.9	34.8	5.35	5 200	7 900	0.042	JR35x40x17
	40	47	16	1	HK4016-2RS	13.4	22.4	3.4	4 900	-	0.037	JR35x40x20
	40	47	18	1	HK4018-RS	18.9	34.8	5.35	4 900	-	0.057	JR35x40x20.5
	40	47	20	1	HK4020	25.1	50.4	8.2	5 200	7 900	0.060	JR35x40x20.5
	40	47	20	1	HK4020-2RS	18.9	34.8	5.35	4 900	-	0.053	JR35x40x20.5
45	45	52	12	1	HK4512	14.1	24.8	3.75	4 600	7 000	0.036	-
	45	52	16	1	HK4516	19.8	38.5	5.95	4 600	7 000	0.048	JR40x45x17
	45	52	18	1	HK4518-RS	19.8	38.5	5.95	4 300	-	0.064	JR40x45x20.5
	45	52	20	1	HK4520	27.2	58.2	8.8	4 600	7 000	0.059	JR40x45x20.5
	45	52	20	1	HK4520-2RS	19.8	38.5	5.95	4 300	-	0.055	JR40x45x20.5
50	50	58	20	1	HK5020	30.9	62.2	8.8	4 100	6 300	0.072	JR45x50x20
	50	58	25	1	HK5025	35.5	74.1	11.7	4 100	6 300	0.092	JR45x50x25.5
55	55	63	20	1	HK5520	31	64.4	10	3 700	5 700	0.079	-
60	60	68	12	1	HK6012	18.6	34.4	5.25	3 400	5 200	0.06	-
	60	68	20	1	HK6020	32.5	70.2	10.9	3 400	5 200	0.09	-

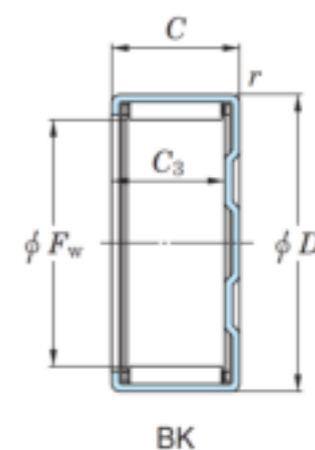
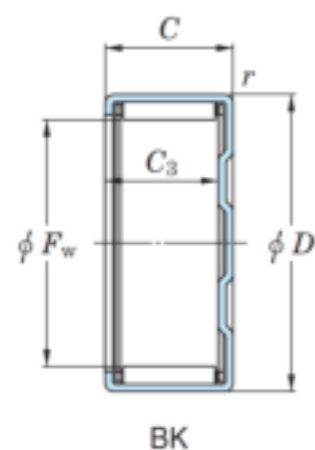

Shaft dia.	Boundary dimensions(mm)					Bearing No.	Basic load ratings(kN)		Fatigue load limit(kN)	Limiting speeds(min-1)		Mass (kg)	Mounting inner ring
	Fw	D	C +0-0.3	C3min.	r min		Cr	COr		Cu	Grease lub		
5	5	9	9	7.4	0.4	BK0509	2.52	2.07	0.32	23000	36000	0.002	
6	6	10	9	7.4	0.4	BK0609	3.14	2.85	0.29	22000	33000	0.003	
7	7	11	9	7.4	0.4	BK0709	3.24	3.1	0.47	21000	2000	0.003	
8	8	12	10	8.4	0.4	BK0810	3.93	4.14	0.6	20000	31000	0.004	JR5x8x12
9	9	13	12	10.4	0.4	BK0912	5.65	6.65	1	19000	30000	0.005	JR6x9x12
10	10	14	10	8.4	0.4	BK1010	4.78	5.51	0.84	19 000	29 000	0.004	JR7x10x10,5
12	12	16	10	8.4	0.4	BK1210	4.96	6.08	0.89	18 000	28 000	0.006	JR8x12x10,5
	12	18	12	9.3	1	BK1212	6.61	7.29	1.1	14 000	22 000	0.012	JR8x12x12,5
15	15	21	12	9.3	1	BK1512	7.16	8.57	1.4	14 000	21 000	0.015	JR12x15x12,5
	15	21	16	13.3	1	BK1516	10.7	14.4	2.2	14 000	21 000	0.019	JR12x15x16,5
16	16	22	12	9.3	1	BK1612	7.76	9.72	1.5	14 000	21 000	0.016	JR12x16x12
	16	22	16	13.3	1	BK1616	11.1	15.3	2.35	14 000	21 000	0.02	JR12x16x16
18	18	24	16	13.3	1	BK1816	11.6	16.8	2.55	12 000	18 000	0.022	JR15x18x16,5
20	20	26	12	9.3	1	BK2012	8.97	12.5	1.9	11 000	16 000	0.017	JR15x20x12
	20	26	16	13.3	1	BK2016	12.4	18.9	2.85	11 000	16 000	0.024	JR17x20x16,5
	20	26	20	17.3	1	BK2020	15.5	25.3	3.95	11 000	16 000	0.027	JR17x20x20,5
25	25	32	16	13.3	1	BK2516	15.16	23.5	3.55	8500	13000	0.031	JR20x25x17
	25	32	20	17.3	1	BK2520	20.6	33.4	5.3	8 500	13 000	0.043	JR20x25x20,5
	25	32	26	23.3	1	BK2526	25.7	44.4	6.95	8 500	13 000	0.051	JR20x25x26,5
	25	32	38	35.3	1	BK2538	35.3	66.9	100.6	8500	13000	0.077	JR20x25x38,5
30	30	37	20	17.3	1	BK3020	22.4	39.6	6.25	7 000	11 000	0.053	JR25x30x20,5
	30	37	26	23.3	1	BK3026	27.4	51.2	7.95	7 000	11 000	0.067	JR25x30x26,5
	30	37	38	35.3	1	BK3038	38.4	79.2	12.5	7 000	11 000	0.093	JR25x30x38,5
35	35	42	20	17.3	1	BK3520	24.5	46.8	7.4	5 900	9 100	0.065	JR30x35x20,5
40	40	47	20	17.3	1	BK4020	25.1	50.4	8	5 200	7 900	0.07	JR35x40x20,5

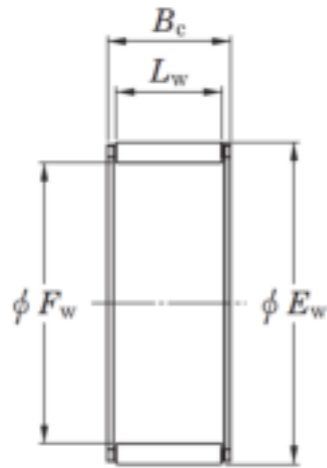

WJ, WJC

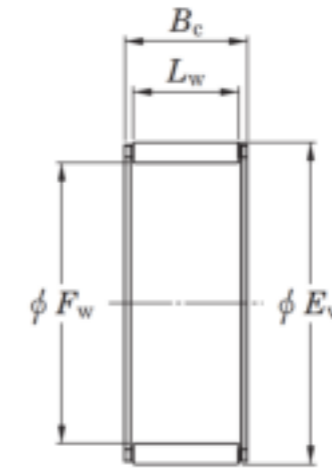

WJ, WJC

Shaft dia. in.	Boundary dimensions (mm)			Bearing No.	Basic load ratings(kN)		Fatigue load limit(kN) Cu	Limiting speeds(min-1)		Recommended dimensions (mm)				Mass(kg)
	Fw	Ew	Bc+0 -0.38		Cr	COr		Grease lub	Oil lub.	Shaft dia.		Housing bore dia.		
										max.	min.	max	min.	
3/4	19.05	25.4	25.4	WJ-121616	26.8	37.2	5.8	16 000	24 000	19.05	19.04	25.42	25.408	0.023
7/8	22.225	28.575	25.4	WJ-141816	29.2	43.5	6.75	13 000	20 000	22.225	22.215	28.595	28.583	0.026
1	25.4	33.338	19.05	WJ-162112	28.1	37.1	5.9	12 000	18 000	25.4	25.39	33.363	33.348	0.029
	25.4	33.338	25.4	WJ-162116	36.8	52.5	8.2	12 000	18 000	25.4	25.39	33.363	33.348	0.038
	25.4	33.338	31.75	WJ-162120	44.5	67.2	10.5	12 000	18 000	25.4	25.39	33.363	33.348	0.048
1 1/8	28.575	38.1	31.75	WJ-182420	52	74.7	11.7	10000	16000	28.575	28.565	38.125	38.11	0.065
	28.575	38.1	25.4	WJ-182416	42.4	57.8	9.05	10 000	16 000	28.575	28.565	38.125	38.11	0.041
1 1/4	31.75	41.275	19.05	WJ-202612	33.4	43.7	7.05	9 300	14 000	31.75	31.74	41.3	41.285	0.043
	31.75	41.275	25.4	WJ-202616	44.1	62.3	9.8	9 300	14 000	31.75	31.74	41.3	41.285	0.061
	31.75	41.275	38.1	WJ-202624	63.6	99.6	15.6	9 300	14 000	31.75	31.74	41.3	41.285	0.085
1 1/2	38.1	47.625	25.4	WJ-243016	47.2	71.6	11.3	7 600	12 000	38.1	38.09	47.65	47.635	0.078
	38.1	47.625	31.75	WJ-243020	57.8	93	14.5	7 600	12 000	38.1	38.09	47.65	47.635	0.083
	38.1	47.625	38.1	WJ-243024	68.1	114.8	18	7 600	12 000	38.1	38.09	47.65	47.635	0.1
1 3/4	44.45	53.975	19.05	WJ-283412	39.5	59.6	9.6	6 400	9 900	44.45	44.44	54.003	53.985	0.058
	44.45	53.975	25.4	WJ-283416	52	85	13.4	6 400	9 900	44.45	44.44	54.003	53.985	0.084
	44.45	53.975	38.1	WJ-283424	74.7	136	21.3	6 400	9 900	44.45	44.44	54.003	53.985	0.115
2	50.8	60.325	19.05	WJ-323812	42.8	69	11.1	5 600	8 600	50.8	50.787	60.353	60.335	0.065
	50.8	60.325	25.40	WJ-323816	56.5	98.0	15.5	5600	8600	50.800	50.787	60.353	60.335	0.105
	50.8	60.325	31.75	WJ-323820	69	127	20	5 600	8 600	50.8	50.787	60.353	60.335	0.108
	50.8	60.325	38.1	WJ-323824	81	157	24.6	5 600	8 600	50.8	50.787	60.353	60.335	0.13
2 1/8	53.975	63.5	25.4	WJ-344016	52.5	92.08	14.6	5 200	8 000	53.975	53.962	63.528	63.51	0.089
	53.975	63.5	38.1	WJ-344024	78.3	153	24	5 200	8 000	53.975	53.962	63.528	63.51	0.137
2 1/4	57.15	66.675	25.4	WJ-364216	53.8	96.08	15.2	4 900	7 500	57.15	57.137	66.703	66.685	0.096
2 1/2	63.5	73.025	25.4	WJ-404616	55.6	104	16.5	4 400	6 700	63.5	63.487	73.053	73.035	0.106
	63.5	73.025	38.1	WJ-404624	83.2	173	27.2	4 400	6 700	63.5	63.487	73.053	73.035	0.179
2 3/4	69.85	79.375	25.40	WJ-445016	57.8	112.54	17.8	4000	6100	69.850	69.837	79.403	79.385	0.116
3	76.2	85.725	25.4	WJ-485416	59.6	120.55	19.1	3 600	5 600	76.2	76.187	85.761	85.738	0.126
	76.2	85.725	38.10	WJ-485424	85.4	191.72	29.9	3600	5600	76.200	76.187	85.761	85.738	0.189

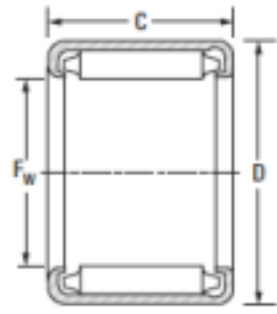

B, BH, NB, NBH

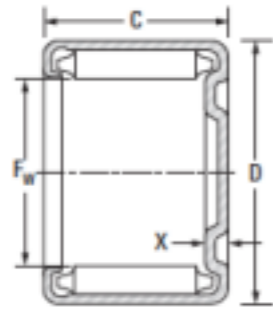

M-1, MH-1

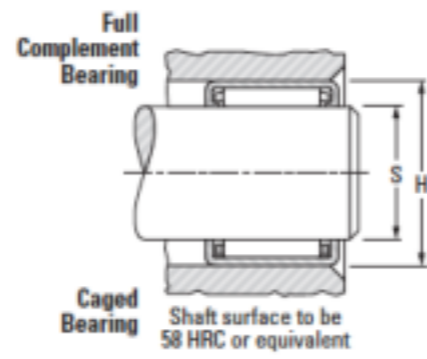

Caged Bearing

Shaft surface to be 58 HRC or equivalent

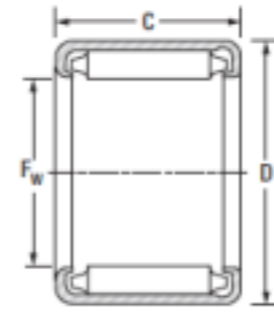

B, BH, NB, NBH

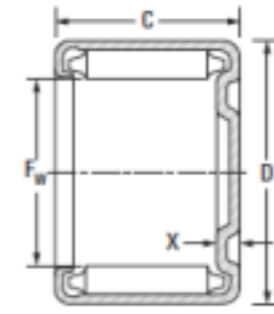

M-1, MH-1

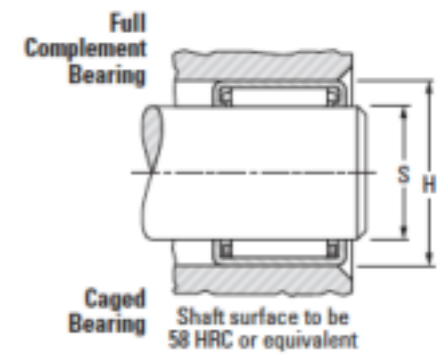

Caged Bearing

Shaft surface to be 58 HRC or equivalent

Shaft Dia.	Fw	D	C	X max.	Bearing Designation		Load Ratings		Fatigue Load Limit	Approx. Wt		Mounting Dimensions				Mounting inner ring	
					Open Ends	Closed One End*	Dynamic	Static		Cu	Open Ends	Closed One End	Shaft		Housing		
							C	CO					Max.	Min.	Max.		Min.
in	mm	mm	mm	mm			kN	kN	kN	kg	kg	mm	mm	mm	mm		
	in	in	in	in			lbf	lbf		lbs	lbs	in	in	in	in		
1/4	6.350	11.113	7.92	2.03	B-45	M-451	3.55	3.68	0.56	0.003	0.004	6.350	6.337	11.125	11.100		
	0.2500	0.4375	0.312	0.080			800	830		0.007	0.008	0.2500	0.2495	0.4380	0.4370		
	6.350	11.113	11.13	2.03	B-47	M-471	5.51	6.46	0.98	0.004	0.005	6.350	6.337	11.125	11.100		
	0.2500	0.4375	0.438	0.080			1240	1450		0.009	0.011	0.2500	0.2495	0.4380	0.4370		
5/16	7.938	12.700	7.92	2.03	B-55	M-551	4.08	4.60	0.70	0.004	0.004	7.938	7.925	12.713	12.687		
	0.3125	0.5000	0.312	0.080			920	1030		0.008	0.009	0.3125	0.3120	0.5005	0.4995		
	7.938	12.700	9.53	-	B-56	-	5.23	6.33	0.97	0.005	-	7.938	7.925	12.713	12.687		
	0.3125	0.5000	0.375	-			1180	1420		0.010	-	0.3125	0.3120	0.5005	0.4995		
	7.938	12.700	11.13	2.03	B-57	M-571	6.33	8.09	1.20	0.005	0.006	7.938	7.925	12.713	12.687		
	0.3125	0.5000	0.438	0.080			1420	1820		0.011	0.013	0.3125	0.3120	0.5005	0.4995		
3/8	9.525	14.288	15.88	2.03	B-610	M-6101	10.4	16.0	2.40	0.008	0.010	9.525	9.512	14.300	14.275		
	0.3750	0.5625	0.625	0.080			2340	3590		0.018	0.021	0.3750	0.3745	0.5630	0.5620		
	9.525	14.288	7.92	2.03	B-65	M-651	4.55	5.53	0.84	0.004	0.005	9.525	9.512	14.300	14.275		
	0.3750	0.5625	0.312	0.080			1020	1240		0.009	0.010	0.3750	0.3745	0.5630	0.5620		
	9.525	14.288	9.53	2.03	B-66	M-661	5.83	7.61	1.15	0.005	0.005	9.525	9.512	14.300	14.275		
	0.3750	0.5625	0.375	0.080			1310	1710		0.011	0.012	0.3750	0.3745	0.5630	0.5620		
	9.525	14.288	11.13	-	B-67	-	7.06	9.72	1.45	0.006	-	9.525	9.512	14.300	14.275		
	0.3750	0.5625	0.438	-			1590	2190		0.013	-	0.3750	0.3745	0.5630	0.5620		
	9.525	14.288	12.70	2.03	B-68	M-681	8.21	11.8	1.80	0.007	0.008	9.525	9.512	14.300	14.275		
	0.3750	0.5625	0.500	0.080			1850	2650		0.015	0.017	0.3750	0.3745	0.5630	0.5620		
	9.525	14.288	14.27	-	B-69	-	9.33	13.9	2.10	0.007	-	9.525	9.512	14.300	14.275		
	0.3750	0.5625	0.562	-			2100	3130		0.016	-	0.3750	0.3745	0.5630	0.5620		
7/16	11.113	15.875	15.88	-	B-710	-	11.4	18.7	2.80	0.010	-	11.113	11.100	15.888	15.862		
	0.4375	0.6250	0.625	-			2560	4200		0.021	-	0.4375	0.4370	0.6255	0.6245		
	11.113	15.875	9.53	-	B-76	-	6.37	8.88	1.35	0.005	-	11.113	11.100	15.888	15.862		
	0.4375	0.6250	0.375	-			1430	2000		0.012	-	0.4375	0.4370	0.6255	0.6245		
	11.113	15.875	12.70	2.03	B-78	M-781	8.97	13.8	2.10	0.008	0.009	11.113	11.100	15.888	15.862		
	0.4375	0.6250	0.500	0.080			2020	3100		0.017	0.019	0.4375	0.4370	0.6255	0.6245		

* Not a stocked range although available on request.

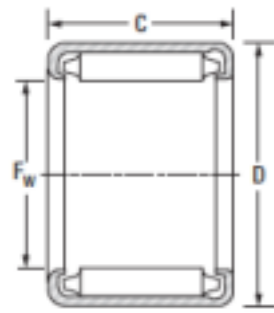

B, BH, NB, NBH

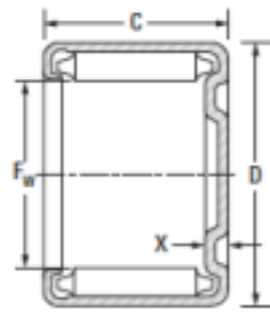

M-1, MH-1

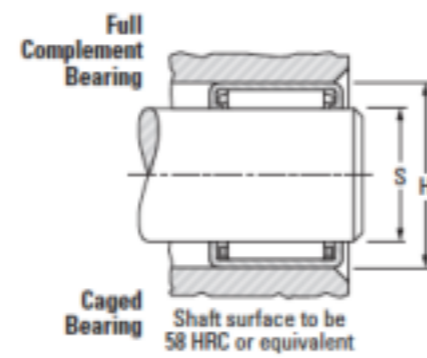

Caged Bearing

Shaft surface to be 58 HRC or equivalent

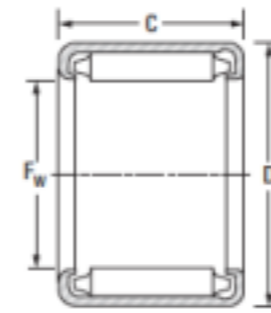

B, BH, NB, NBH

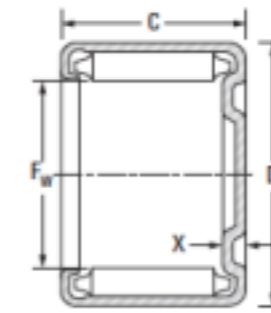

M-1, MH-1

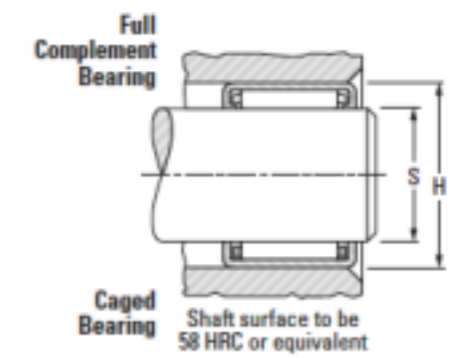

Caged Bearing

Shaft surface to be 58 HRC or equivalent

Shaft Dia.	Fw	D	C	X max.	Bearing Designation		Load Ratings		Fatigue Load Limit	Approx. Wt		Mounting Dimensions				Mounting inner ring	
					Open Ends	Closed One End*	Dynamic	Static		Cu	Open Ends	Closed One End	Shaft		Housing		
							C	CO					Max.	Min.	Max.		Min.
in	mm	mm	mm	mm			kN	kN		kg	kg	mm	mm	mm	mm		
	in	in	in	in			lbf	lbf	kN	lbs	lbs	in	in	in	in		
1/2	12.700	17.463	15.88	2.03	B-810	M-8101	12.2	21.3	3.20	0.010	0.012	12.70	12.687	17.475	17.450	-	
	0.5000	0.6875	0.625	0.080			2750	4800		0.023	0.026	0.5000	0.4995	0.6880	0.6870		
	12.700	17.463	19.05	2.03	B-812	M-8121	14.7	26.9	4.20	0.013	0.014	12.700	12.687	17.475	17.450	-	
	0.5000	0.6875	0.750	0.080			3300	6050		0.028	0.031	0.5000	0.4995	0.6880	0.6870		
	12.700	17.463	7.92	2.03	B-85	M-851	5.36	7.38	1.15	0.005	0.006	12.700	12.687	17.475	17.450	IRA-5	
	0.5000	0.6875	0.312	0.080			1200	1660		0.012	0.014	0.5000	0.4995	0.6880	0.6870		
	12.700	17.463	9.53	2.03	B-86	M-861	6.87	10.2	1.55	0.006	0.007	12.700	12.687	17.475	17.450	IRA-5	
	0.5000	0.6875	0.375	0.080			1540	2290		0.014	0.016	0.5000	0.4995	0.6880	0.6870		
	12.700	17.463	11.13	2.03	B-87	M-871	8.31	13.0	1.95	0.007	0.008	12.700	12.687	17.475	17.450	IRA-5	
	0.5000	0.6875	0.438	0.080			1870	2920		0.016	0.018	0.5000	0.4995	0.6880	0.6870		
12.700	17.463	12.70	2.03	B-88	-	9.63	15.7	2.40	0.009	0.010	12.700	12.687	17.475	17.450	IRA-5		
0.5000	0.6875	0.500	0.080			2160	3530		0.019	0.021	0.5000	0.4995	0.6880	0.6870			
9/16	14.288	19.050	15.88	2.03	B-910	M-9101	13.1	24.0	3.60	0.012	0.013	14.288	14.275	19.063	19.037	IR-612(1)	
	0.5625	0.7500	0.625	0.080			2940	5400		0.026	0.029	0.5625	0.5620	0.7505	0.7495		
	14.288	19.050	19.05	2.03	B-912	M-9121	15.6	30.3	4.70	0.014	0.015	14.288	14.275	19.063	19.037	IR-612(1)	
	0.5625	0.7500	0.750	0.080			3510	6820		0.031	0.034	0.5625	0.5620	0.7505	0.7495		
	14.288	19.050	7.92	2.03	B-95	M-951	5.72	8.31	1.25	0.006	0.006	14.288	14.275	19.063	19.037	IR-68	
	0.5625	0.7500	0.312	0.080			1290	1870		0.013	0.014	0.5625	0.5620	0.7505	0.7495		
	14.288	19.050	9.53	2.03	B-96	M-961	7.33	11.4	1.75	0.007	0.008	14.288	14.275	19.063	19.037	IR-68	
	0.5625	0.7500	0.375	0.080			1650	2570		0.015	0.018	0.5625	0.5620	0.7505	0.7495		
	14.288	19.050	12.70	2.03	B-98	M-981	10.3	17.7	2.70	0.009	0.010	14.288	14.275	19.063	19.037	IR-68	
0.5625	0.7500	0.500	0.080	2320			3990	0.020		0.023	0.5625	0.5620	0.7505	0.7495			

* Not a stocked range although available on request.

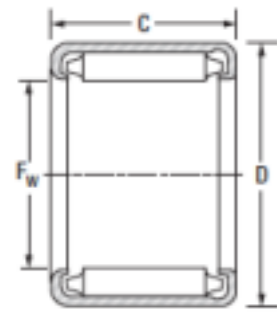

B, BH, NB, NBH

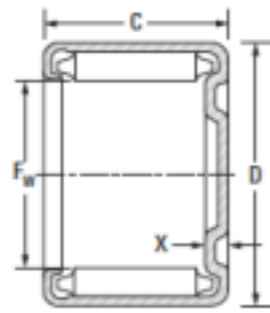

M-1, MH-1

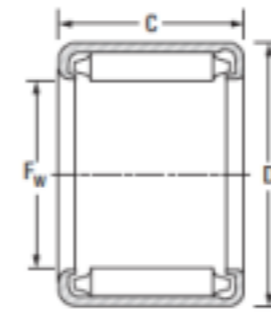
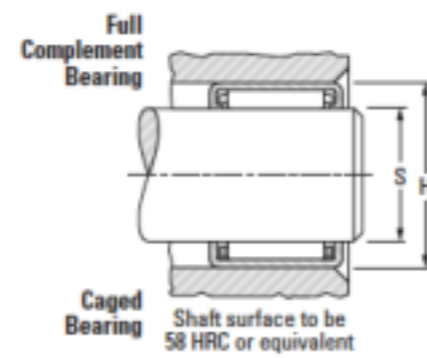

B, BH, NB, NBH

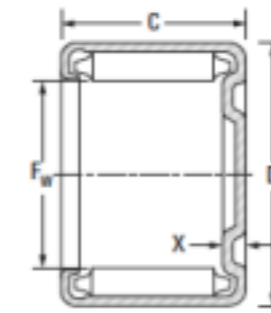

M-1, MH-1

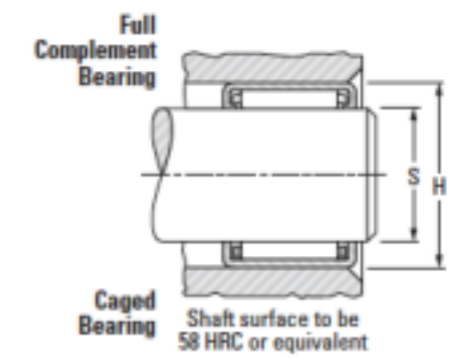

Shaft Dia.	Fw	D	C	X max.	Bearing Designation		Load Ratings		Fatigue Load Limit	Approx. Wt		Mounting Dimensions				Mounting inner ring	
					Open Ends	Closed One End*	Dynamic	Static		Cu	Open Ends	Closed One End	Shaft		Housing		
							C	CO					Max.	Min.	Max.		Min.
in	mm	mm	mm	mm			kN	kN	kN	kg	kg	mm	mm	mm	mm		
	in	in	in	in			lbf	lbf		lbs	lbs	in	in	in	in		
5/8	15.875	20.638	15.88	2.03	B-1010	M-10101	13.8	26.7	4	0.013	0.015	15.875	15.862	20.650	20.625	IR-612-1	
	0.6250	0.8125	0.625	0.080			3110	6000		0.028	0.032	0.625	0.6245	0.813	0.812		
	15.875	20.638	19.05	2.03	B-1012	M-10121	16.6	33.7	5.25	0.015	0.017	15.875	15.862	20.650	20.625	IR-612-1	
	0.6250	0.8125	0.750	0.080			3720	7580		0.034	0.038	0.6250	0.6245	0.8130	0.8120		
	15.875	20.638	7.92	2.03	B-105	M-1051	6.05	9.24	1.40	0.006	0.007	15.875	15.862	20.650	20.625	IR-68-1	
	0.6250	0.8125	0.312	0.080			1360	2080		0.014	0.016	0.6250	0.6245	0.8130	0.8120		
	15.875	20.638	11.13	2.03	B-107	M-1071	9.39	16.2	2.45	0.009	0.010	15.875	15.862	20.650	20.625	IR-68-1	
	0.6250	0.8125	0.438	0.080			2110	3650		0.020	0.022	0.6250	0.6245	0.8130	0.8120		
	15.875	20.638	12.70	2.03	B-108	M-1081	10.9	19.7	3	0.010	0.012	15.875	15.862	20.650	20.625	IR-68-1	
0.6250	0.8125	0.500	0.080	2450			4430	0.022		0.026	0.6250	0.6245	0.8130	0.8120			
11/16	17.463	22.212	15.88	2.03	B-1110	M-11101	14.6	29.4	4.40	0.014	0.015	17.463	17.450	22.238	22.212	-	
	0.6875	0.8745	0.625	0.080			3270	6610		0.030	0.034	0.6875	0.6870	0.8755	0.8745		
	17.463	22.212	19.05	2.03	B-1112	M-11121	17.4	37.1	5.75	0.016	0.019	17.463	17.450	22.238	22.212	-	
	0.6875	0.8745	0.750	0.080			3920	8340		0.036	0.041	0.6875	0.6870	0.8755	0.8745		
	17.463	22.212	9.53	2.03	B-116	M-1161	8.17	14.0	2.15	0.008	0.009	17.463	17.450	22.238	22.212	-	
	0.6875	0.8745	0.375	0.080			1840	3140		0.018	0.020	0.6875	0.6870	0.8755	0.8745		
	17.463	22.212	12.70	2.03	B-118	M-1181	11.5	21.7	3.30	0.011	0.012	17.463	17.450	22.238	22.212	-	
	0.6875	0.8745	0.500	0.080			2580	4880		0.024	0.027	0.6875	0.6870	0.8755	0.8745		

* Not a stocked range although available on request.

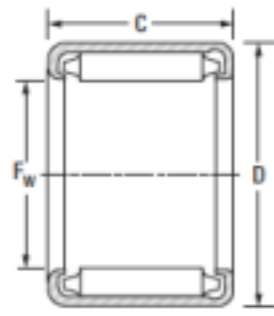

B, BH, NB, NBH

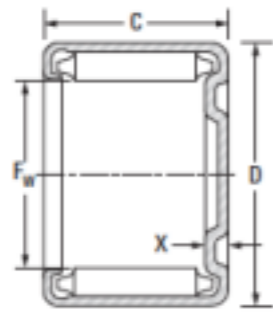

M-1, MH-1

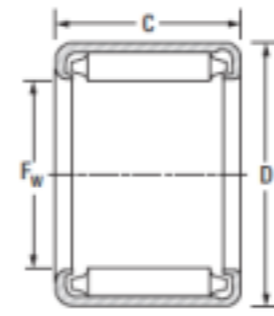
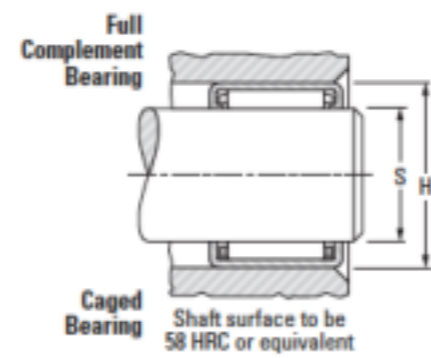

B, BH, NB, NBH

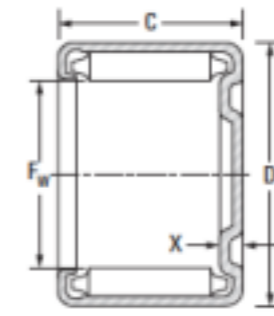

M-1, MH-1

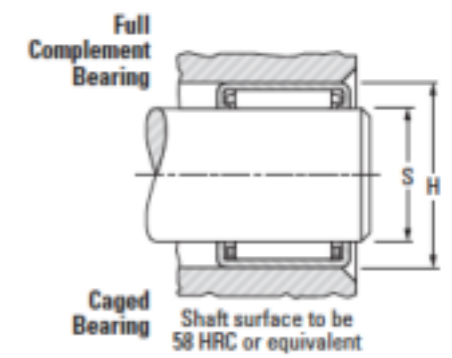

Shaft Dia.	Fw	D	C	X max.	Bearing Designation		Load Ratings		Fatigue Load Limit	Approx. Wt		Mounting Dimensions				Mounting inner ring
					Open Ends	Closed One End*	Dynamic	Static		Open Ends	Closed One End	Shaft		Housing		
							C	CO				Max.	Min.	Max.	Min.	
in	mm	mm	mm	mm			kN	kN	kg	kg	mm	mm	mm	mm		
	in	in	in	in			lbf	lbf	lbs	lbs	in	in	in	in		
3/4	19.050	25.400	15.88	2.29	B-1210	M-12101	18.1	30.4	4.60	0.020	0.024	19.050	19.037	25.413	25.387	-
	0.7500	1.0000	0.625				0.090	4070		6830	0.024	0.024	0.045	0.052	0.7500	0.7495
	19.050	25.400	19.05	0.090	B-1212	M-12121	21.9	38.7	5.95	0.024	0.028	19.050	19.037	25.413	25.387	-
	0.7500	1.0000	0.750				4930	8710		0.054	0.062	0.7500	0.7495	1.0005	0.9995	-
	19.050	25.400	9.53	0.090	B-126	M-1261	9.70	13.6	2.10	0.012	0.014	19.050	19.037	25.413	25.387	-
	0.7500	1.0000	0.375				2180	3050		0.027	0.031	0.7500	0.7495	1.0005	0.9995	-
	19.050	25.400	12.70	0.090	B-128	M-1281	14.1	22.0	3.30	0.016	0.019	19.050	19.037	25.413	25.387	-
0.7500	1.0000	0.500	3170				4940	0.036		0.041	0.7500	0.7495	1.0005	0.9995	-	
13/16	20.638	26.988	22.23	0.090	B-1314	M-13141	26.7	51.1	7.90	0.031	0.035	20.638	20.625	27.000	26.975	-
	0.8125	1.0625	0.875				6010	11490		0.068	0.077	0.8125	0.8120	1.0630	1.0620	-
	20.638	26.988	25.40	-	B-1316	M-13161	30.3	60.2	9.25	0.035	0.040	20.638	20.625	27.000	26.975	-
	0.8125	1.0625	1.000				6820	13530		0.078	0.088	0.8125	0.8120	1.0630	1.0620	-
	20.635	26.988	9.53	-	B-136	-	10.1	14.7	2.25	0.013	-	20.638	20.625	27.000	26.975	-
	0.8125	1.0625	0.375				2280	3300		0.029	-	0.8125	0.8120	1.0630	1.0620	-
	20.638	26.988	12.70	0.090	B-138	M-1381	14.7	23.8	3.60	0.018	0.020	20.638	20.625	27.000	26.975	-
	0.8125	1.0625	0.500				3300	5350		0.039	0.044	0.8125	0.8120	1.0630	1.0620	-
7/8	22.225	28.575	19.05	0.090	B-1412	M-14121	23.9	45.2	6.95	0.028	0.032	22.225	22.212	28.588	28.562	-
	0.8750	1.1250	0.750				5370	10160		0.062	0.070	0.8750	0.8745	1.1255	1.1245	-
	22.225	28.575	25.40	-	B-1416	M-14161	31.6	64.8	10.0	0.038	0.043	22.225	22.212	28.588	28.562	-
	0.8750	1.1250	1.000				7100	14570		0.083	0.094	0.8750	0.8745	1.1255	1.1245	-
	22.225	28.575	28.58	-	B-1418	-	35.2	74.6	11.4	0.043	-	22.225	22.212	28.588	28.562	-
	0.8750	1.1250	1.125				7920	16770		0.094	-	0.8750	0.8745	1.1255	1.1245	-
	22.225	28.575	9.53	0.090	B-146	M-1461	10.6	15.8	2.45	0.014	0.016	22.225	22.212	28.588	28.562	-
	0.8750	1.1250	0.375				2380	3560		0.031	0.035	0.8750	0.8745	1.1255	1.1245	-
	22.225	28.575	12.70	0.090	B-148	M-1481	15.4	25.6	3.85	0.019	0.022	22.225	22.212	28.588	28.562	-
0.8750	1.1250	0.500	3450				5760	0.042		0.048	0.8750	0.8745	1.1255	1.1245	-	

* Not a stocked range although available on request.

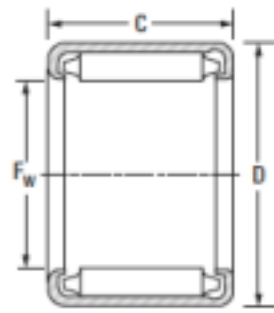

B, BH, NB, NBH

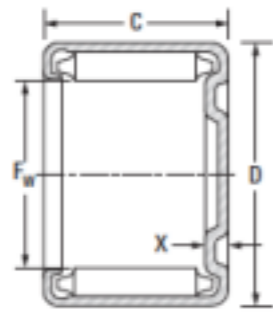

M-1, MH-1

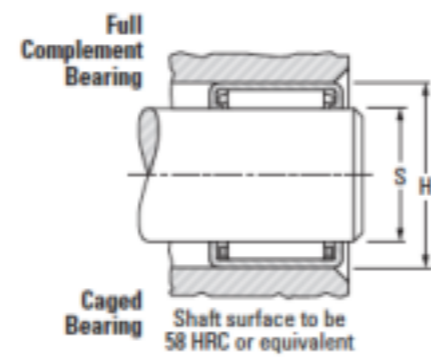

Caged Bearing
Shaft surface to be 58 HRC or equivalent

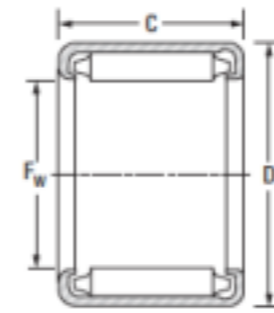

B, BH, NB, NBH

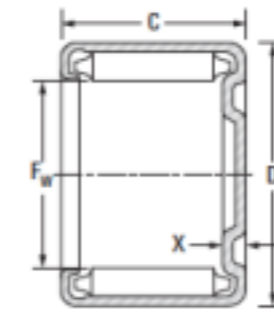

M-1, MH-1

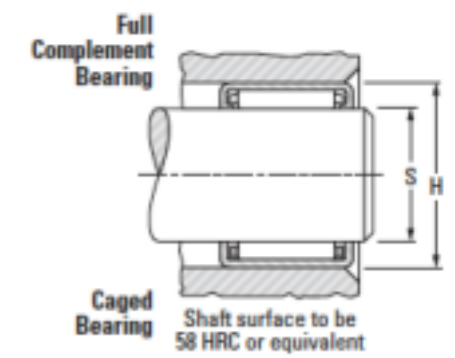

Caged Bearing
Shaft surface to be 58 HRC or equivalent

Shaft Dia.	Fw	D	C	X max.	Bearing Designation		Load Ratings		Fatigue Load Limit	Approx. Wt		Mounting Dimensions				Mounting inner ring	
					Open Ends	Closed One End*	Dynamic	Static		Cu	Open Ends	Closed One End	Shaft		Housing		
							C	CO					Max.	Min.	Max.		Min.
15/16	23.813	30.163	25.40	2.29	B-1516	M-15161	32.8	69.5	10.7	0.040	0.045	23.813	23.800	30.175	30.150	-	
	0.9375	1.1875	1.000	0.090			7370	15620		0.088	0.100	0.9375	0.9370	1.1880	1.1870		
1	25.400	31.750	15.88	2.29	B-1610	M-16101	21.2	40.5	6.15	0.026	0.030	25.400	25.387	31.763	31.737	IR-1212	
	1.0000	1.2500	0.625	0.090			4770	9110		0.058	0.066	1.0000	0.9995	1.2505	1.2495		
	25.400	31.750	19.05	2.29	B-1612	M-16121	25.7	51.7	7.95	0.032	0.036	25.400	25.87	31.763	31.737	IR-1212	
	1.0000	1.2500	0.750	0.090			5770	11620		0.070	0.080	1.0000	0.9995	1.2505	1.2495		
	25.400	31.750	25.40	2.29	B-1616	M-16161	34.0	74.1	11.4	0.043	0.048	25.400	25.387	31.763	31.737	IR-1216	
	1.0000	1.2500	1.000	0.090			7640	16660		0.094	0.106	1.0000	0.9995	1.2505	1.2495		
	25.400	31.750	9.53	-	B-166	-	11.3	18.1	2.80	0.016	-	25.400	25.387	31.763	31.737	IR-128	
	1.0000	1.2500	0.375	-			2550	4070		0.035	-	1.0000	0.9995	1.2505	1.2495		
	25.400	31.750	11.13	2.29	B-167	M-1671	14.0	23.7	3.60	0.019	0.021	25.400	25.387	31.763	31.737	IR-128	
	1.0000	1.2500	0.438	0.090			3140	5320		0.041	0.046	1.0000	0.9995	1.2505	1.2495		
25.400	31.750	12.70	2.29	B-168	M-1681	16.5	29.3	4.45	0.021	0.024	25.400	25.387	31.763	31.737	IR-128		
1.0000	1.2500	0.5000	0.090			3710	6590		0.047	0.053	1.0000	0.9995	1.2505	1.2495			
1 1/16	26.988	33.338	15.88	2.29	B-1710	M-17101	21.9	43.1	6.55	0.028	0.32	26.988	26.975	33.350	33.325	-	
	1.0625	1.3125	0.625	0.090			4930	9680		0.062	0.070	1.0625	1.0620	1.3130	1.3120		
1 1/8	28.575	34.925	19.05	2.29	B-1812	M-18121	27.3	58.2	8.90	0.035	0.040	28.575	28.562	34.938	34.912	IR-1416	
	1.1250	1.3750	0.750	0.090			6140	13080		0.078	0.088	1.1250	1.1245	1.3755	1.3745		
	28.575	34.925	25.40	2.29	B-1816	M-18161	36.1	83.4	12.8	0.047	0.054	28.575	28.562	34.938	34.912	IR-1416	
	1.1250	1.3750	1.000	0.090			8120	18750		0.104	0.118	1.1250	1.1245	1.3755	1.3745		
	28.575	34.925	9.53	2.29	B-186	M-1861	12.1	20.4	3.10	0.018	0.020	28.575	28.562	34.938	34.912	IR-1416(1)	
	1.1250	1.3750	0.375	0.090			2720	4580		0.039	0.044	1.1250	1.1245	1.3755	1.3745		
	28.575	34.925	12.70	2.29	B-188	M-1881	17.6	33.0	4.95	0.024	0.027	28.575	28.562	34.938	34.912	IR-1416(1)	
1.1250	1.3750	0.500	0.090	3950			7420	0.052		0.059	1.1250	1.1245	1.3755	1.3745			
1 3/16	30.163	38.100	25.40	-	B-1916	-	39.9	83.7	13.0	0.064	-	30.163	30.150	38.113	38.087	-	
	1.1875	1.500	1.000	-			8970	18820		0.140	-	1.1875	1.1870	1.5005	1.4995		

* Not a stocked range although available on request.

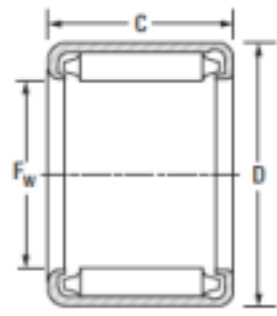

B, BH, NB, NBH

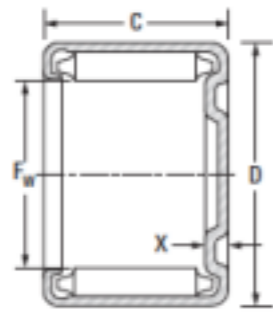

M-1, MH-1

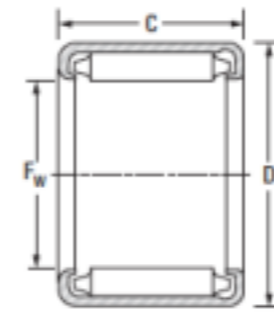
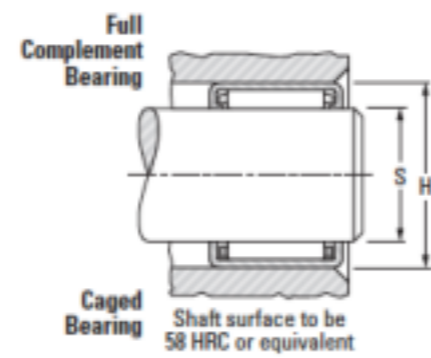

B, BH, NB, NBH

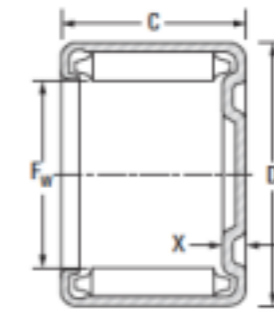

M-1, MH-1

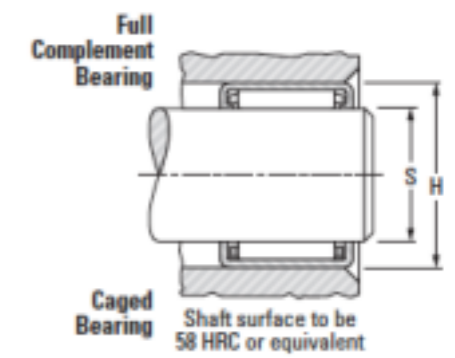

Shaft Dia.	Fw	D	C	X max.	Bearing Designation		Load Ratings		Fatigue Load Limit	Approx. Wt		Mounting Dimensions				Mounting inner ring	
					Open Ends	Closed One End*	Dynamic	Static		Cu	Open Ends	Closed One End	Shaft		Housing		
							C	CO					Max.	Min.	Max.		Min.
in	mm	mm	mm	mm			kN	kN	kN	kg	kg	mm	mm	mm	mm		
	in	in	in	in			lbf	lbf		lbs	lbs	in	in	in	in		
1 1/4	31.750	38.100	15.88	2.29	B-2010	M-20101	23.9	50.7	7.70	0.032	0.044	31.750	31.737	38.113	38.087	IR-1612	
	1.2500	1.5000	0.625	0.090			5370	11400		0.071	0.097	1.2500	1.2495	1.5005	1.4995		
	31.750	38.100	19.05	2.29	B-2012	M-20121	28.9	64.7	9.90	0.039	0.045	31.750	31.737	38.113	38.087	IR-1612	
	1.2500	1.5000	0.750	0.090			6490	14540		0.086	0.099	1.2500	1.2495	1.5005	1.4995		
	31.750	38.100	25.40	2.29	B-2016	M-20161	38.2	92.7	14.2	0.052	0.059	31.750	31.737	38.113	38.087	IR-1616(1)	
	1.2500	1.5000	1.000	0.090			8590	20840		0.114	0.130	1.2500	1.2495	1.5005	1.4995		
	31.750	38.100	31.75	2.29	B-2020	M-20201	46.9	121	18.4	0.065	0.073	31.750	31.737	38.113	38.087	-	
	1.2500	1.5000	1.250	0.090			10540	27200		0.143	0.162	1.2500	1.2495	1.5005	1.4995		
	31.750	38.100	12.70	2.29	B-208	M-2081	18.6	36.7	5.50	0.026	0.029	31.750	31.737	38.113	38.087	IR-1612	
1.2500	1.5000	0.500	0.090	4170			8250	0.057		0.065	1.2500	1.2495	1.5005	1.4995			
1 5/16	33.338	41.275	15.88	2.79	B-2110	M-21101	25.5	48.4	7.25	0.043	0.049	33.338	33.325	41.288	41.262	-	
	1.3125	1.6250	0.625	0.110			5740	10880		0.095	0.108	1.3125	1.3120	1.6255	1.6245		
	33.338	41.275	12.70	2.79	B-218	M-2181	19.3	33.7	5.00	0.034	0.039	33.338	33.325	41.288	41.262	-	
	1.3125	1.6250	0.500	0.110			4330	7570		0.076	0.086	1.3125	1.3120	1.6255	1.6245		
1 3/8	34.925	41.275	19.05	2.29	B-2212	M-22121	30.4	71.2	10.9	0.043	0.049	34.925	34.912	41.288	41.262	IR-1812	
	1.3750	1.6250	0.750	0.090			6830	16000		0.094	0.107	1.3750	1.3745	1.6255	1.6245		
	34.925	41.275	25.40	2.29	B-2216	M-22161	40.2	102	15.7	0.057	0.064	34.925	34.912	41.288	41.262	IR-1816	
	1.3750	1.6250	1.000	0.090			9030	22900		0.125	0.142	1.3750	1.3745	1.6255	1.6245		
	34.925	41.275	31.75	2.29	B-2220	M-22201	49.3	133	20.3	0.071	0.080	34.925	34.912	41.288	41.262	IR-1820	
	1.3750	1.6250	1.250	0.090			11080	29900		0.156	0.177	1.3750	1.3745	1.6255	1.6245		
	34.925	41.275	12.70	2.29	B-228	M-2281	19.5	40.3	6.05	0.028	0.032	34.925	34.912	41.288	41.262	IR-1812	
	1.3750	1.6250	0.500	0.090			4390	9060		0.062	0.070	1.3750	1.3745	1.6255	1.6245		

* Not a stocked range although available on request.

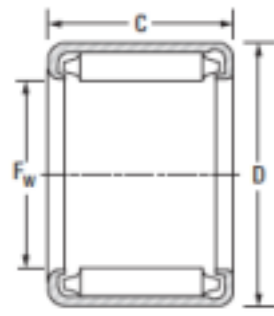

B, BH, NB, NBH

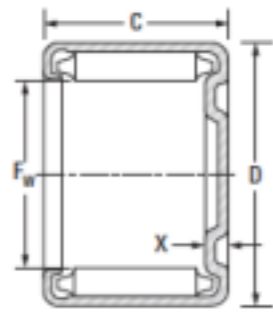

M-1, MH-1

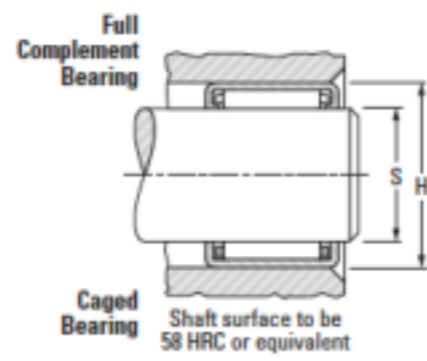

Caged Bearing

Shaft surface to be 58 HRC or equivalent

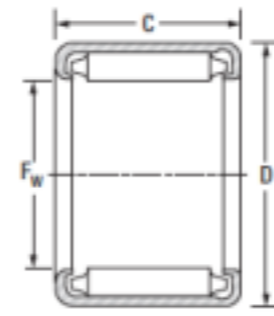

B, BH, NB, NBH

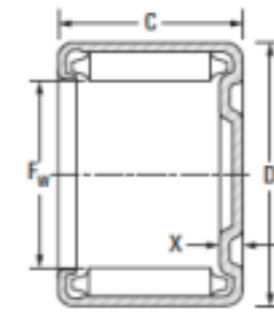

M-1, MH-1

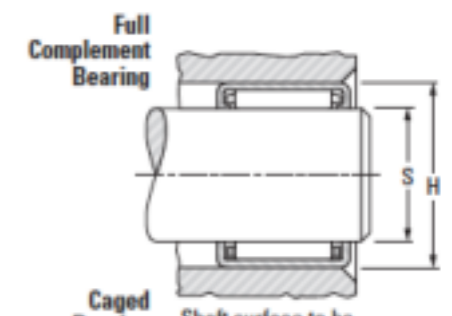

Caged Bearing

Shaft surface to be 58 HRC or equivalent

Shaft Dia.	Fw	D	C	X max.	Bearing Designation		Load Ratings		Fatigue Load Limit	Approx. Wt		Mounting Dimensions				Mounting inner ring	
					Open Ends	Closed One End*	Dynamic	Static		Cu	Open Ends	Closed One End	Shaft		Housing		
							C	CO					Max.	Min.	Max.		Min.
in	mm	mm	mm	mm			kN	kN			kg	kg	mm	mm	mm	mm	
	in	in	in	in			lbf	lbf	kN		lbs	lbs	in	in	in	in	
1 1/2	38.100	47.625	12.70	3.05	B-248	M-2481	22.3	37.1	5.60	0.048	0.054	38.100	38.087	47.638	47.612	IR-1916	
	1.5000	1.8750	0.500	0.120			5020	8340									0.105
	38.100	47.625	15.88	3.05	B-2410	M-24101	29.9	53.9	8.10	0.060	0.068	38.100	38.087	47.638	47.612	IR-1916	
	1.500	1.8750	0.625	0.120			6720	12120									0.132
	38.100	47.625	19.05	3.05	B-2412	M-24121	36.9	70.7	11.1	0.072	0.081	38.100	38.087	47.638	47.612	IR-1916	
	1.5000	1.8750	0.750	0.120			8290	15900									0.158
	38.100	47.625	22.23	3.05	B-2414	M-24141	43.5	87.5	13.6	0.083	0.095	38.100	38.087	47.638	47.612	IR-916	
	1.5000	1.8750	0.875	0.120			9780	19670									0.184
	38.100	47.625	25.40	3.05	B-2416	M-24161	49.7	104	16.1	0.096	0.108	38.100	38.087	47.638	47.612	IR-1916	
	1.5000	1.8750	1.000	0.120			11170	23380									0.211
	38.100	47.625	31.75	3.05	B-2420	m-24201	62.0	138	21.2	0.119	0.135	38.100	38.087	47.638	47.612	IR-1920	
	1.5000	1.8750	1.250	0.120			13940	31000									0.263
38.100	47.625	12.70	3.05	B-248	M-2481	22.3	37.1	5.60	0.048	0.054	38.100	38.087	47.638	47.612	IR-916		
1.5000	1.8750	0.500	0.120			5020	8340									0.105	0.119
1 5/8	41.275	50.800	15.88	3.05	B-2610	M-26101	30.6	57.4	8.60	0.064	0.073	41.275	41.262	50.813	50.787	IR-2020	
	1.6250	2.000	0.625	0.120			6890	12900									0.141
	41.275	50.800	25.40	-	B-2616	-	51.4	112	17.4	0.103	-	41.275	41.262	50.813	50.787	IR-2020	
	1.6250	2.0000	1.000	-			11550	25200									0.226
	41.275	50.800	31.75	3.05	B-2620	M-26201	64.0	148	22.9	0.128	0.145	41.275	41.262	50.813	50.787	IR-2020 (1)	
	1.6250	2.0000	1.250	0.120			14400	33270									0.282
	41.275	50.800	12.70	-	B-268	-	22.7	39.2	5.85	0.051	-	41.275	41.262	50.813	50.787	IR-2020 (1)	
1.6250	2.0000	0.500	-	5100			8820	0.113									-

* Not a stocked range although available on request.

Needle Roller Bearings Shell Type (Full Complement) B Imperial Series



Finer Power Transmissions P/L | www.finerpt.com



Finer Power Transmissions P/L | www.finerpt.com

Needle Roller Bearings Shell Type (Full Complement) B Imperial Series

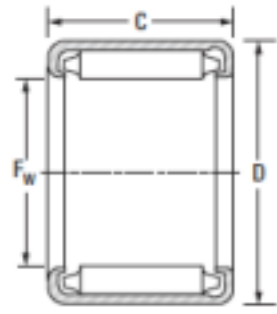

B, BH, NB, NBH

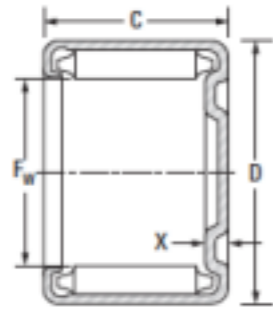

M-1, MH-1

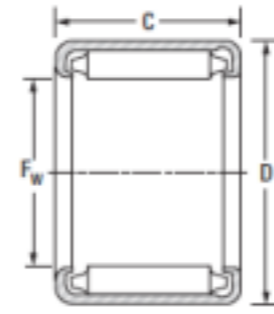
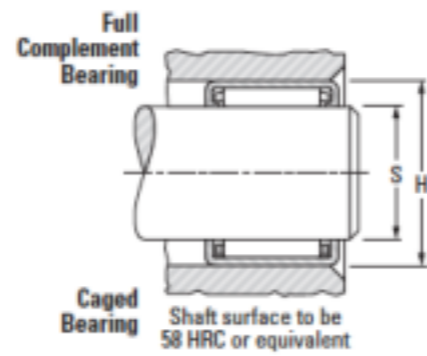

B, BH, NB, NBH

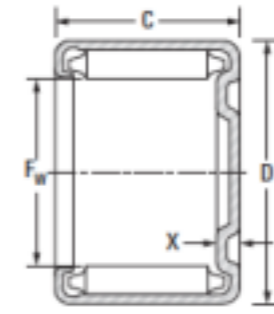

M-1, MH-1

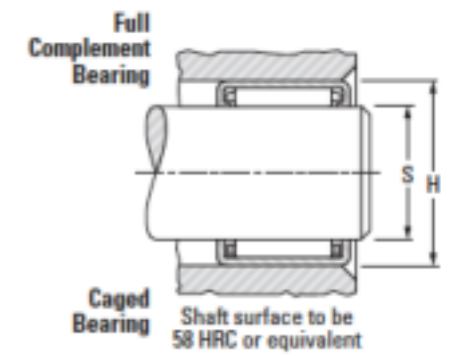

Shaft Dia.	Fw	D	C	X max.	Bearing Designation		Load Ratings		Fatigue Load Limit	Approx. Wt		Mounting Dimensions				Mounting inner ring	
					Open Ends	Closed One End*	Dynamic	Static		Cu	Open Ends	Closed One End	Shaft		Housing		
							C	CO					Max.	Min.	Max.		Min.
in	mm	mm	mm	mm			kN	kN	kN	kg	kg	mm	mm	mm	mm		
1 3/4	44.450	53.975	19.05	3.05	B-2812	M-28121	39.3	81.5	12.8	0.082	0.093	44.450	44.437	53.988	53.962	IR-2316	
	1.7500	2.1250	0.750	0.120			8830	18320		0.181	0.205	1.7500	1.7495	2.1255	2.1245		
	44.450	53.975	25.40	3.05	B-2816	M-28161	53.3	121		18.8	0.110	0.124	44.450	44.437	53.988	53.962	IR-2316
	1.7500	2.1250	1.000	0.120			11980	27100			0.242	0.274	1.7500	1.7495	2.1255	2.1245	
	44.450	53.975	31.75	-	B-2820	-	66.4	160		24.7	0.137	-	44.450	44.437	53.988	53.962	IR-2324
	1.7500	2.1250	1.250	-			14930	36000			0.302	-	1.7500	1.7495	2.1255	2.1245	
	44.450	53.975	38.10	3.05	B-2824	M-26241	78.7	199		30.5	0.165	0.186	44.450	44.437	53.988	53.962	IR-2324
1.7500	2.1250	1.500	0.120	17700			44800	0.363	0.411		1.7500	1.7495	2.1255	2.1245			
1 7/8	47.625	57.150	19.05	-	B-3012	-	41.5	88.4	13.9	0.088	-	47.625	47.612	57.163	57.137	-	
	1.8750	2.2500	0.750	-			9330	19870		0.193	-	1.8750	1.8745	2.2505	2.2495		
	47.625	57.150	25.40	3.05	B-3016	M-30161	56.0	130		20.1	0.117	0.132	47.625	47.612	57.163	57.137	-
	1.8750	2.2500	1.000	0.120			12600	29200			0.258	0.292	1.8750	1.8745	2.2505	2.2495	
	47.625	57.150	12.70	3.05	B-308	M-3081	25.1	46.4		7.00	0.059	0.066	47.625	47.612	57.163	57.137	-
	1.8750	2.2500	0.500	0.120			5650	10430			0.129	0.146	1.8750	1.8745	2.2505	2.2495	
2	50.800	60.325	22.23	-	B-3214	-	50.1	116	18.0	0.108	-	50.800	50.785	60.338	60.312	-	
	2.0000	2.3750	0.875	-			11260	26080		0.239	-	2.0000	1.9994	2.3755	2.3745		
	50.800	60.325	25.40	3.05	B-3216	M-32161	57.5	138		21.5	0.124	0.140	50.800	50.785	60.338	60.312	-
	2.0000	2.3750	1.000	0.120			12930	31000			0.273	0.309	2.0000	1.9994	2.3755	2.3745	
	50.800	60.325	31.75	3.05	B-3220	M-32201	71.5	183		28.3	0.155	0.175	50.800	50.785	60.338	60.312	-
	2.000	2.3750	1.250	0.120			16070	41100			0.341	0.386	2.0000	1.9994	2.3755	2.3745	
	50.800	60.325	44.45	3.05	B-3228	M-32281	97.6	272		41.9	0.217	0.245	50.800	50.785	60.338	60.312	-
	2.0000	2.3750	1.750	0.120			21940	61150			0.478	0.541	2.0000	1.9994	2.3755	2.3745	
	50.800	60.325	12.70	3.05	B-328	M-3281	25.4	48.2		7.20	0.062	0.070	50.800	50.785	60.338	60.312	-
2.0000	2.3750	0.500	0.120	5710			10840	0.136	0.154		2.0000	1.9994	2.3755	2.3745			

* Not a stocked range although available on request.

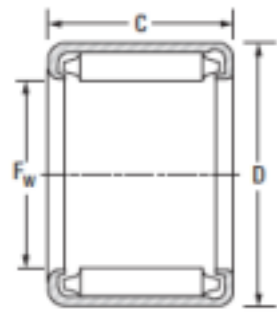

B, BH, NB, NBH

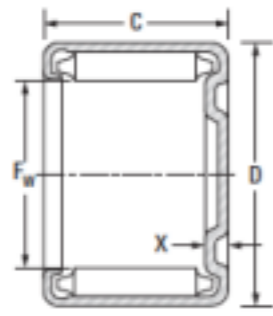

M-1, MH-1

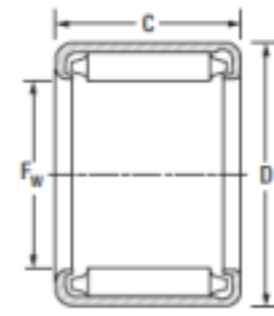
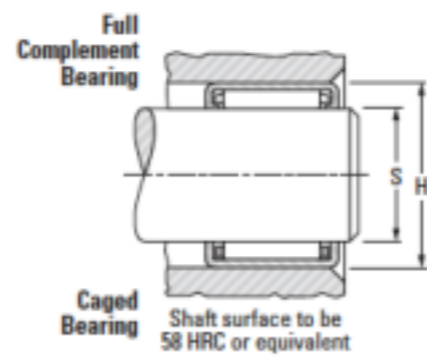

B, BH, NB, NBH

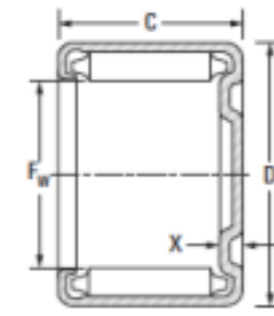

M-1, MH-1

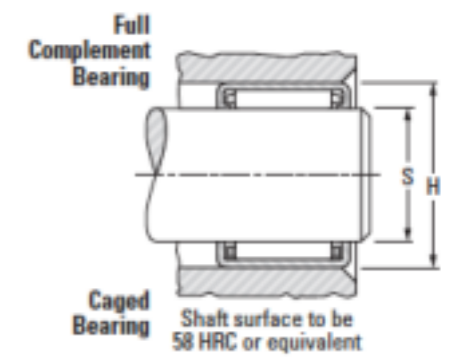

Shaft Dia.	Fw	D	C	X max.	Bearing Designation		Load Ratings		Fatigue Load Limit	Approx. Wt		Mounting Dimensions				Mounting inner ring
					Open Ends	Closed One End*	Dynamic C	Static CO		Cu	Open Ends	Closed One End	Shaft		Housing	
in	mm	mm	mm	mm			kN	kN	kN	kg	kg	Max.	Min.	Max.	Min.	
	in	in	in	in			lbf	lbf		lbs	lbs	in	in	in	in	
2 1/8	53.975	63.500	19.05	-	B-3412	-	43.6	99.0	15.5	0.098	-	53.975	53.960	63.513	63.487	IR-3024
	2.1250	2.5000	0.750	-			9790	22260		0.216	-	2.1250	2.1244	2.5005	2.4995	
	53.975	63.500	25.40	3.05	B-3416	M-34161	59.1	147	22.8	0.131	0.148	53.975	53.960	65.513	63.487	IR-3024
	2.1250	2.5000	1.000	0.120				13290		33000	0.289	0.327	2.1250	2.1244	2.5005	
	53.975	63.500	38.10	3.05	B-3424	M-34241	87.3	242	37.1	0.196	0.223	53.975	53.960	63.513	63.487	IR-3024
	2.1250	2.5000	1.500	0.120				19630		54400	0.433	0.491	2.1250	2.1244	2.5005	
	53.975	63.500	12.70	-	B-348	-	26.1	51.3	7.65	0.065	-	53.975	53.960	63.513	63.487	IR-3024
2.1250	2.5000	0.500	-			5870	11530	0.144		-	2.1250	2.1244	2.5005	2.4995		
2 1/4	57.150	66.675	19.05	3.30	B-3612	M-36121	46	105	16.5	0.103	0.117	57.150	57.135	66.688	66.662	-
	2.2500	2.6250	0.750	0.130				10340		23700	0.228	0.258	2.2500	2.2494	2.6255	
	57.150	66.675	31.75	-	B-3620	-	77.5	206	31.8	0.172	-	57.150	57.135	66.668	66.662	-
	2.2500	2.6250	1.250	-			17420	46400		0.380	-	2.2500	2.2494	2.6255	2.6245	
	57.150	66.675	38.10	3.30	B-3624	M-36241	91.9	257	39.6	0.207	0.235	57.150	57.135	66.688	66.662	-
2.2500	2.6250	1.500	0.130				20660	57700		0.456	0.517	2.2500	2.2494	2.6255	2.6245	
2 5/8	66.675	76.200	25.40	3.30	B-4216	M-42161	66.7	182	23.9	0.159	0.181	66.675	66.660	76.213	76.187	-
	2.6250	3.0000	1.000	0.130				15000		40900	0.351	0.398	2.6250	2.6244	3.0005	
2 3/4	69.850	79.375	15.88	-	B-4410	-	41.0	98.0	14.9	0.104	-	69.850	69.835	79.388	79.362	-
	2.7500	3.1250	0.625	-			9210	22000		0.229	-	2.7500	2.7494	3.1255	3.1245	
	69.850	79.375	25.40	-	B-4416	-	68.80	191	29.5	0.166	-	69.850	69.835	79.388	79.362	IR-4016
	2.7500	3.1250	1.000	-			15470	42940		0.366	-	2.7500	2.7494	3.1255	3.1245	
3 1/2	88.900	101.600	19.05	-	B-5612	-	65.1	150	22.9	0.212	-	88.900	88.885	101.613	101.587	-
	3.5000	4.000	0.750	-			14630	33700		0.468	-	3.5000	3.4994	4.0005	3.9995	

* Not a stocked range although available on request.

Needle Roller Bearings Shell Type (Full Complement)

BH Heavy Series



Needle Roller Bearings Shell Type (Full Complement)

BH Heavy Series

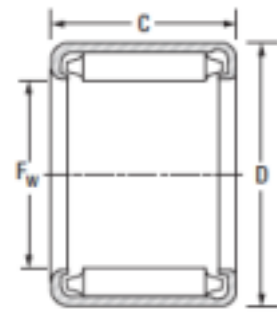

B, BH, NB, NBH

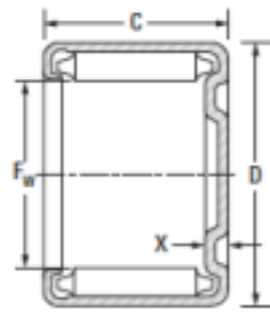

M-1, MH-1

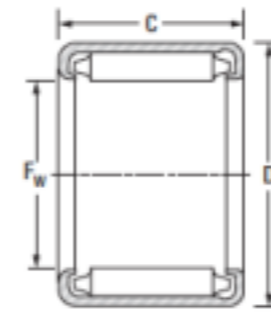
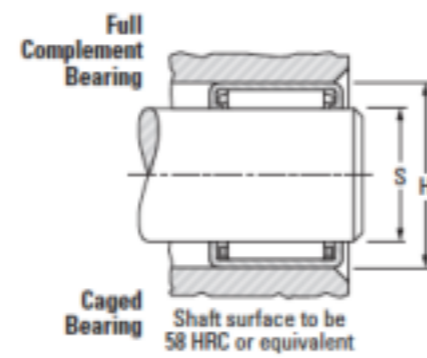

B, BH, NB, NBH

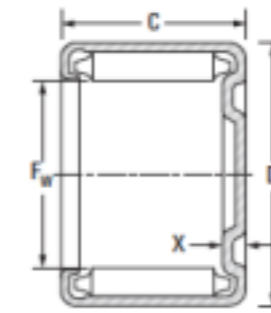

M-1, MH-1

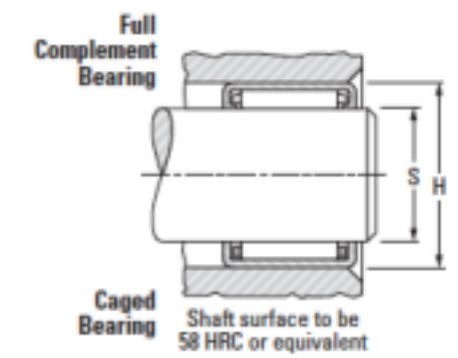

Shaft Dia.	Fw	D	C	X max.	Bearing Designation		Load Ratings		Fatigue Load Limit	Approx. Wt		Mounting Dimensions				Mounting inner ring	
					Open Ends	Closed One End	Dynamic	Static		Cu	Open Ends	Closed One End	Shaft		Housing		
							C	CO					Max.	Min.	Max.		Min.
in	mm	mm	mm	mm			kN	kN			kg	mm	mm	mm	mm		
	in	in	in	in			lbf	kN			lbs	in	in	in	in		
5/16	7.938	14.288	11.13	2.29	BH-57	MH-571	7.01	7.33	1.10	0.007	0.008	7.938	7.925	14.300	14.275	-	
	0.3125	0.5625	0.438	0.090			1580	1650	1.10	0.016	0.018	0.3125	0.3120	0.5630	0.5620	-	
3/8	9.525	15.875	12.70	-	BH-68	-	9.35	10.9	1.65	0.010	-	9.525	9.512	15.888	15.862	IRA-3	
	0.3750	0.625	0.5	-			2100	2460	1.65	0.021	-	0.3750	0.3745	0.6255	0.6245	IRA-3	
7/16	11.113	15.875	12.7	-	BH-78	-	10.3	12.8	1.95	0.010	-	11.113	11.100	17.475	17.450	IRA-5	
	0.4375	0.6875	0.500	-			2320	2870	1.95	0.023	-	0.4375	0.4370	0.6880	0.6870	IRA-5	
1/2	12.700	19.050	11.13	-	BH-87	-	9.46	11.8	1.80	0.010	-	12.700	12.687	19.063	19.037	IRA-5	
	0.5000	0.7500	0.4388	-			2130	2650	1.80	0.023	-	0.5000	0.4995	0.7505	0.7495	IRA-5	
	12.700	19.050	15.88	-	BH-810	-	14.4	20.2	3.05	0.015	-	12.700	12.687	19.063	19.037	-	
	0.5000	0.7500	0.625	-			3230	4540	3.05	0.033	-	0.5000	0.4995	0.7507	0.7495	-	
	12.700	19.050	19.05	2.29	BH-812	MH-81821	17.4	25.8	3.95	0.018	0.020	12.700	12.687	19.063	19.037	-	
	0.5000	0.7500	0.750	0.090			3910	5790	3.95	0.039	0.044	0.5000	0.4995	0.7505	0.7495	-	
5/8	15.875	22.12	12.7	2.29	BH-108	MH-108	12.7	18.3	2.75	0.014	0.016	15.875	15.862	22.238	22.212	IR-68-1	
	0.6250	0.8745	0.500	0.090			2860	4110	2.75	0.031	0.035	0.6250	0.6245	0.8755	0.8745	IR-68-1	
	15.875	22.212	15.88	-	BH-1010	-	16.4	25.3	3.85	0.018	-	15.875	15.862	22.238	22.212	IR-612-1	
	0.6250	0.8745	0.625	-			3680	5680	3.85	0.039	-	0.6250	0.6245	0.8755	0.8745	IR-612-1	
	15.875	22.212	19.05	-	BH-1012	-	19.8	32.3	4.95	0.021	-	15.875	15.862	22.238	22.212	IR-612-1	
	0.6250	0.8745	0.75	-			4450	7250	4.95	0.047	-	0.6250	0.6245	0.8755	0.8745	IR-612-1	
	15.875	22.212	25.4	-	BH-1016	-	26.2	46.2	7.10	0.028	-	15.875	15.862	22.238	22.212	-	
0.6250	0.8745	1	-	5890			10390	7.10	0.062	-	0.6250	0.6245	0.8755	0.8745	-		
11/16	17.463	23.813	15.88	2.29	BH-1110	-	17.3	27.8	4.25	0.019	0.021	17.463	17.450	23.825	23.8	-	
	0.6875	0.9375	0.625	0.09			3890	6250	4.25	0.042	0.047	0.6875	0.6870	0.9380	0.9370	-	
	17.463	23.813	19.05	-	BH-1112	-	20.9	35.5	5.45	0.023	-	17.463	17.450	23.825	23.8	-	
	0.6875	0.9375	0.75	-			4700	7980	5.45	0.051	-	0.6875	0.6870	0.9380	0.9370	-	
13/16	20.638	28.575	19.05	2.79	BH-1312	MH-13121	24.2	39	6.10	0.034	0.039	20.638	20.625	28.588	28.562	-	
	0.8125	1.1250	0.750	0.11			5440	8760	6.10	0.076	0.086	0.8125	0.8120	1.1255	1.1245	-	

Needle Roller Bearings Shell Type (Full Complement)

BH Heavy Series



Finer Power Transmissions P/L | www.finerpt.com



Finer Power Transmissions P/L | www.finerpt.com

Needle Roller Bearings Shell Type (Full Complement)

BH Heavy Series

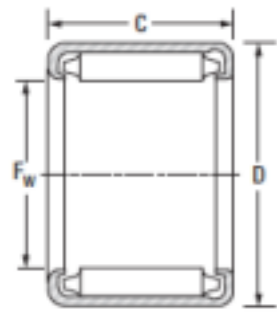

B, BH, NB, NBH

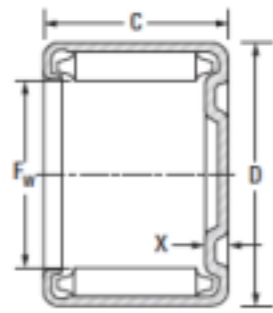

M-1, MH-1

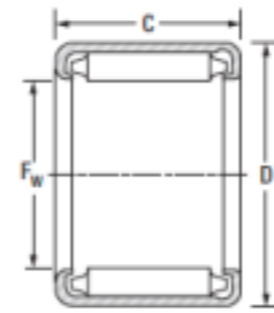
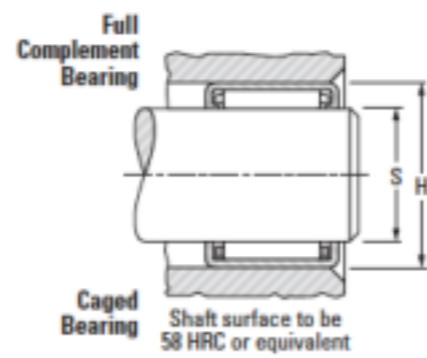

B, BH, NB, NBH

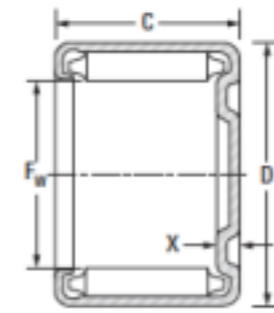

M-1, MH-1

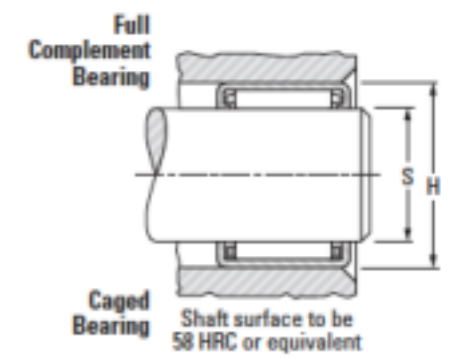

Shaft Dia.	Fw	D	C	X max.	Bearing Designation		Load Ratings		Fatigue Load Limit	Approx. Wt		Mounting Dimensions				Mounting inner ring	
					Open Ends	Closed One End	Dynamic	Static		Cu	Open Ends	Closed One End	Shaft		Housing		
							C	CO					Max.	Min.	Max.		Min.
in	mm	mm	mm	mm			kN	CO	kN	kg	lbs	mm	mm	mm	mm		
	in	in	in	in			lbf					in	in	in	in		
7/8	22.225	30.163	15.88	2.79	BH-1410	MH-14101	20.3	32.2	4.85	0.03	0.035	22.225	22.212	30.175	30.150	IR-1012 (1)	
	0.8750	1.1875	0.625	0.11			4570	7240		4.85	0.067	0.076	0.8750	0.8745	1.188	1.187	IR-1012 (1)
	22.225	30.163	19.05	2.79	BH-1412	MH-14121	25	42	6.55	0.036	0.041	22.225	22.212	30.175	30.150	IR-1012 (1)	
	0.8750	1.1875	0.750	0.110			5620	9440		6.55	0.080	0.091	0.8750	0.8745	1.1880	1.1870	IR-1012 (1)
	22.225	30.163	25.40	-	BH-1416	-	33.7	61.6	9.6	0.049	-	22.225	22.212	30.175	30.150	IR-1016	
	0.8750	1.1875	1.000	-			7570	13850		9.6	0.107	-	0.8750	0.8745	1.1880	1.1870	IR-1016
1	25.4	33.338	15.88	-	BH-1610	-	22.0	36.8	5.50	0.034	-	25.400	25.387	33.350	33.325	IR-1212	
	1.000	1.3125	0.625	-			4950	8280		5.50	0.075	-	1.000	0.9995	1.3130	1.312	IR-1212
	25.4	33.338	19.05	2.79	BH-1612	MH-16121	27.1	48.0	7.45	0.041	0.046	25.400	25.387	33.350	33.325	IR-1212	
	1.0000	1.3125	0.750	0.110			6090	10800		7.45	0.090	0.102	1.0000	0.9995	1.3130	1.3120	IR-1212
	25.4	33.338	25.4	2.79	BH-1616	MH-16161	36.5	70.4	10.9	0.054	0.062	25.400	25.387	33.350	33.325	IR-1216 (1)	
	1.000	1.3125	1.000	0.110			8200	15830		10.9	0.120	0.136	1.0000	0.9995	1.3130	1.3120	IR-1216 (1)
	25.4	33.338	31.75	-	BH-1620	-	45.2	92.8	14.2	0.068	-	25.400	25.387	33.50	33.325	IR-1220	
	1.000	1.3125	1.250	-			10160	20860		14.2	0.150	-	1.0000	0.9995	1.3130	1.3120	IR-1220
25.4	33.338	38.10	2.79	BH-1624	MH-16241	53.5	115	17.7	0.082	0.093	25.4	25.387	33.350	33.325	IR-1224		
1.000	1.3125	1.500	0.110			12030	25900		17.7	0.180	0.204	1.0000	0.9995	1.3130	1.3120	IR-1224	
1 1/8	28.575	38.100	19.05	3.05	BH-1812	MH-18121	31.5	52.5	8.30	0.056	0.063	28.575	28.562	38.113.38	0.8745	IR-1416 (1)	
	1.1250	1.5000	0.750	0.120			7090	11900		8.30	0.123	0.138	1.1250	1.1245	1.5005	1.4995	IR-1416 (1)
	28.575	38.100	25.40	3.05	BH-1816	MH-18161	42.5	77.8	12.0	0.074	0.084	28.575	28.562	38.113	38.087	IR-1416 (1)	
	1.1250	1.500	1.000	0.120			9560	17500		12.0	0.164	0.186	1.1250	1.1245	1.5005	1.4995	IR-1416 (1)
	28.575	38.100	31.75	3.05	BH-1820	MH-18201	53.0	103	15.8	0.093	0.105	28.575	28.562	38.113	38.087	-	
	1.1250	1.5000	1.250	0.120			11910	23200		15.8	0.205	0.232	1.1250	1.1245	1.5005	1.4995	-
1 1/4	31.750	41.275	12.70	3.05	BH-208	MH-2081	19.7	30.0	4.50	0.041	0.046	31.750	31.737	41.288	41.262	IR-1612	
	1.2500	1.6250	0.500	0.120			4420	6750		4.50	0.090	0.102	1.2500	1.2495	1.6255	1.6245	IR-1612
	31.750	41.275	19.05	3.05	BH-2012	MH-20121	33.1	58.6	9.10	0.061	0.069	31.750	31.737	41.288	41.262	IR-1612	
	1.2500	1.6250	0.750	0.120			7440	13170		9.10	0.135	0.153	1.2500	1.2495	1.6255	1.6245	IR-1612
	31.750	41.275	25.40	3.05	BH-2016	MH-20161	44.9	86.6	13.4	0.081	0.092	31.750	31.737	41.288	41.262	IR-1616 (1)	
	1.2500	1.6250	1.000	0.120			10100	19470		13.4	0.179	0.203	1.2500	1.2495	1.6255	1.6245	IR-1616 (1)
	31.750	41.275	31.75	3.05	BH-2020	MH-20201	55.9	115	17.6	0.102	0.115	31.750	31.737	41.288	41.262	-	
	1.2500	1.6250	1.250	0.120			12570	25800		17.6	0.224	0.254	1.2500	1.2495	1.6255	1.6245	-

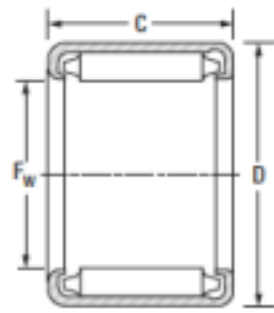

B, BH, NB, NBH

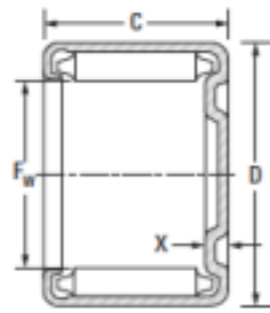

M-1, MH-1

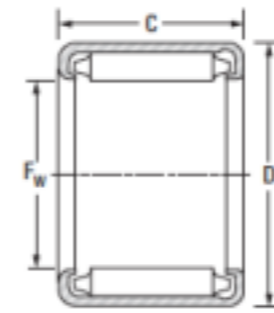
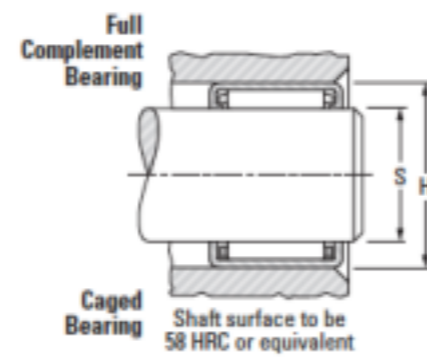

B, BH, NB, NBH

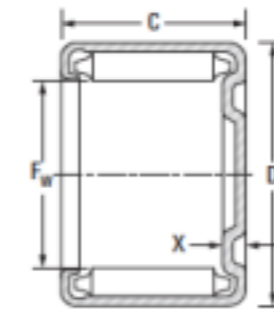

M-1, MH-1

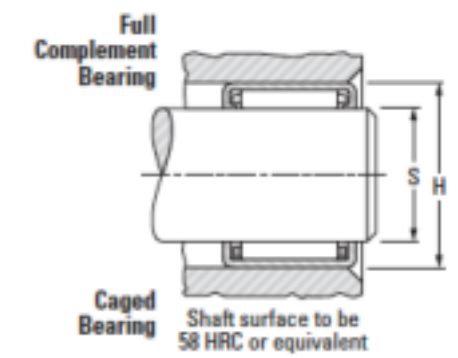

Shaft Dia.	Fw	D	C	X max.	Bearing Designation		Load Ratings		Fatigue Load Limit	Approx. Wt		Mounting Dimensions				Mounting inner ring
					Open Ends	Closed One End	Dynamic	Static		Cu	Open Ends	Closed One End	Shaft		Housing	
C	CO	kN	kg	Max.			Min.	Max.	Min.							
in	mm	mm	mm	mm			kN	kg	kN	kg	mm	mm	mm	mm		
	in	in	in	in			lbf	lbs			in	in	in	in		
1 3/8	34.925	44.450	15.88	-	BH-2210	-	28.5	48.9	7.45	0.055	-	34.925	34.912	44.463	44.437	IR-1812
	1.3750	1.7500	0.6256	-			6410	11000	7.45	0.122	-	1.3750	1.3745	1.7505	1.7495	IR-1812
	34.925	44.450	19.05	3.05	BH-2212	MH-22121	35.3	64.3	10.0	0.066	0.075	34.925	34.912	44.463	44.437	IR-1812
	1.3750	1.7500	0.750	0.120				7930	14450	10.0	0.146	0.165	1.3750	1.3745	1.7505	1.7495
	34.925	44.450	25.40	3.05	BH-2216	MH-22161	47.6	94.8	14.7	0.088	0.100	34.925	34.912	44.463	44.437	IR-1816
	1.3750	1.7500	1.000	0.120				10700	21300	14.7	0.195	0.221	1.3750	1.3745	1.7505	1.7495
	34.925	44.450	31.75	-	BH-2220	-	59.4	126	19.4	0.111	0.125	34.925	34.912	44.463	44.437	IR-1820
	1.3750	1.750	1.250	-				13350	28300	19.4	0.244	0.276	1.3750	1.3745	1.7505	1.7495
2 1/16	52.388	64.292	19.05	-	BH-3312	-	46.1	86.9	13.4	0.122	-	52.388	52.372	64.305	64.280	IR-2916
	2.0625	2.5312	0.750	-				10360	19540	13.4	0.269	-	2.0625	2.0619	5.5317	2.5307
	52.388	64.292	25.40	3.56	BH-3316	MH-33161	64.2	133	20.7	0.162	0.184	52.388	52.372	64.305	64.280	IR-2916
	2.0625	2.5312	1.000	0.140				14430	29900	20.7	0.358	0.406	2.0625	2.0619	2.5317	2.5307

Needle Roller Thrust Bearings

AXK Metric Series

Koyo

Finer Power Transmissions P/L | www.finerpt.com

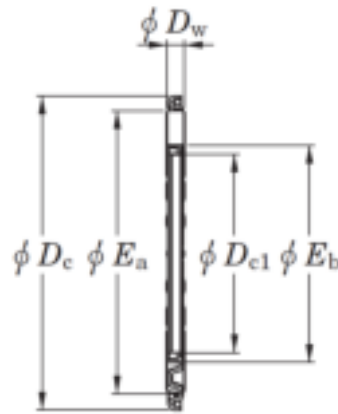

AXK

shaft dia.	Dc1	Dc	Dw	Ea	Eb	Ra max	Bearing no.	Basic load ratings (kN)		Fatigue Load limit (kN) Cu	Limiting speed (min-1)	Mass(kg)
								Cr	Cor			
6	6	19	2	16.9	7.8	0.3	AXK0619TN	6.37	14.3	1.4	23 000	0.001
8	8	21	2	18.6	9.6	0.3	AXK0821TN	8.34	21.1	2	20 000	0.001
10	10	24	2	22.5	11	0.3	AXK1024	9.32	25.9	2.9	17 000	0.003
12	12	26	2	24.5	13	0.3	AXK1226	10.8	32.3	3.4	15 000	0.004
15	15	28	2	27	17	0.3	AXK1528	11.1	35.2	3.35	15 000	0.004
17	17	30	2	28.7	18.3	0.3	AXK1730	11.7	38.7	3.7	14 000	0.004
20	20	35	2	34	22	0.3	AXK2035	12.8	45.4	4.4	12 000	0.006
25	25	42	2	41	29	0.6	AXK2542	14.3	56.8	5.5	10 000	0.007
30	30	47	2	46	35	0.6	AXK3047	16	68.1	6.6	9 000	0.009
35	35	52	2	51	40	0.6	AXK3552	17.4	79.5	7.7	8 100	0.01
40	40	60	3	58	45	0.6	AXK4060	27.1	110	11.9	7 000	0.016
45	45	65	3	63	50	0.6	AXK4565	29	124	13.4	6500	0.02
50	50	70	3	68	55	0.6	AXK5070	30.8	137	14.9	6 000	0.02
55	55	78	3	76	60	0.6	AXK5578	39.4	195	20.5	5 300	0.026
60	60	85	3	83	65	0.6	AXK6085	44.5	234	24.7	4 900	0.035
65	65	90	3	88	70	0.6	AXK6590	46.7	254	26.8	4 600	0.036
70	70	95	4	93	74	0.6	AXK7095	53.8	253	28	4 400	0.055
75	75	100	4	98	79	0.6	AXK75100	55.1	266	29.4	4 200	0.058
100	100	135	4	133	105	0.6	AXK100135	90.2	552	56.4	3 100	0.106
110	110	145	4	143	115	0.6	AXK110145	93.2	591	59	2 800	0.117
120	120	155	4	153	125	0.6	AXK120155	98.5	650	63.5	2 700	0.126
130	130	170	5	167	136	0.6	AXK130170	132	829	78.7	2 400	0.198
140	140	180	5	177	146	0.6	AXK140180	136	887	82.5	2 300	0.221
150	150	190	5	187	156	0.6	AXK150190	141	944	86.2	2 200	0.225
160	160	200	5	197	166	0.6	AXK160200	146	1000	89.9	2 100	0.249

Needle Roller Thrust Bearings

AS Metric Washer Series

Koyo

Finer Power Transmissions P/L | www.finerpt.com

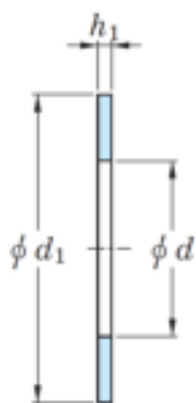

AS
($h_1 = 1.0$)

Washer Dimensions (mm)		AS Metric Washers		
d	d1	h1 (mm)	Bearing No.	Mass (kg)
6	19	1	AS0619	0.001
8	21	1	AS0821	0.002
10	24	1	AS1024	0.003
12	26	1	AS1226	0.003
15	28	1	AS1528	0.003
17	30	1	AS1730	0.003
20	35	1	AS2035	0.005
25	42	1	AS2542	0.007
30	47	1	AS3047	0.008
35	52	1	AS3552	0.009
40	60	1	AS4060	0.012
45	65	1	AS4565	0.013
50	70	1	AS5070	0.014
55	78	1	AS5578	0.018
60	85	1	AS6085	0.022
65	90	1	AS6590	0.023
70	95	1	AS7095	0.025
75	100	1	AS75100	0.027
100	135	1	AS100135	0.05
110	145	1	AS110145	0.055
120	155	1	AS120155	0.059
130	170	1	AS130170	0.074
140	180	1	AS140180	0.078
150	190	1	AS150190	0.083
160	200	1	AS160200	0.089

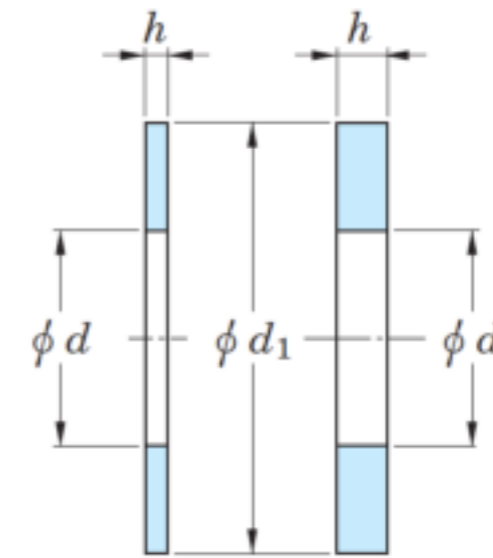
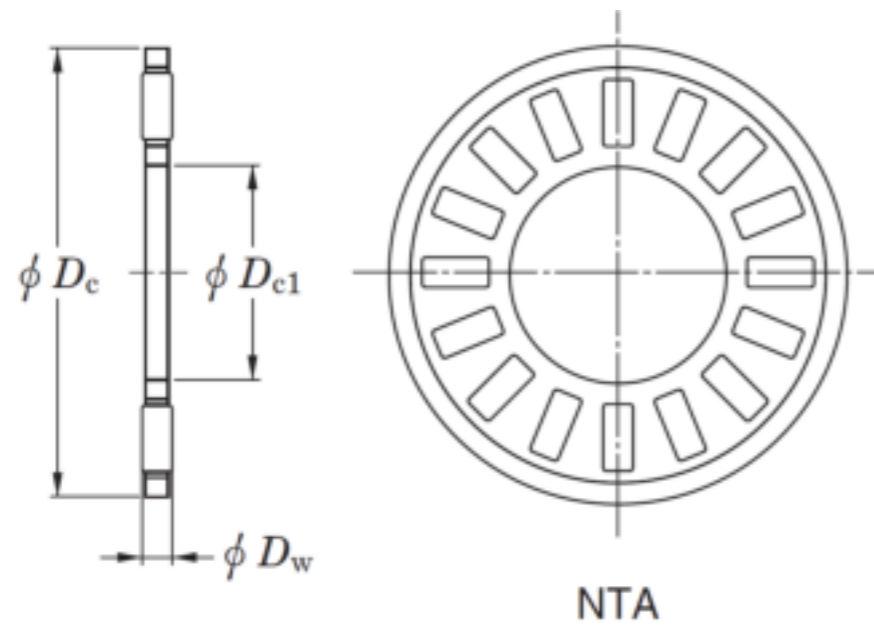

shaft dia. (inch)	Dc1	Dc	Dw	Ea	Eb	Bearing no.	Basic load ratings (kN)		Fatigue Load limit (kN) Cu	Limiting speed (min ⁻¹)	Mass (kg)	Washer No.	Washer Dimensions mm				Piloting dimensions(mm)		Dia. to clear O.D.(mm)	Washer mass (kg)
							Cr	Cor					d	d1	h		S			
											TRA Washers			max.	min.	max.	min.	H 2)		
1/4	6.35	17.45	1.984	8.636	14.732	NTA-411	5.12	10.76	1.05	26000	0.001	TRA-411	6.35	17.45	0.81	0.76	6.35	6.27	18.26	0.001
												TRB-411	6.35	17.45	1.60	1.52	6.35	6.27	18.26	0.002
												TRC-411	6.35	17.45	2.41	2.34	6.35	6.27	18.26	0.004
3/8	9.53	20.625	1.984	11.68	18.034	NTA-613	6.05	14.32	1.40	22000	0.002	TRA-613	9.53	20.62	0.81	0.76	9.53	9.45	21.44	0.001
												TRB-613	9.53	20.62	1.60	1.52	9.53	9.45	21.44	0.003
												TRC-613	9.53	20.62	2.41	2.34	9.53	9.45	21.44	0.004
1/2	12.70	23.80	1.984	14.99	21.08	NTA-815	7.16	19.13	1.85	19000	0.002	TRA-815	12.70	23.80	0.81	0.76	12.70	12.62	24.61	0.002
												TRB-815	12.70	23.80	1.60	1.52	12.70	12.62	24.61	0.004
												TRC-815	12.70	23.80	2.41	2.34	12.70	12.62	24.61	0.005
9/16	14.275	25.40	1.9837	16.51	22.606	NTA-916	7.70	21.53	2.10	18000	0.003	TRA-916	14.27	25.40	0.81	0.76	14.27	14.20	26.19	0.002
												TRB-916	14.27	25.40	1.60	1.52	14.27	14.20	26.19	0.004
												TRC-916	14.27	25.40	2.41	2.34	14.27	14.20	26.19	0.006
5/8	15.88	28.575	1.9837	18.03	25.908	NTA-1018	9.79	30.38	2.85	15000	0.003	TRA-1018	15.88	28.58	0.81	0.76	15.88	15.8	29.36	0.003
												TRB-1018	15.88	28.58	1.6	1.52	15.88	15.8	29.36	0.005
												TRC-1018	15.88	28.58	2.41	2.34	15.88	15.8	29.36	0.008
												TRD-1018	15.88	28.58	3.2	3.12	15.88	15.8	29.36	0.011
												TRE-1018	15.8	28.58	3.99	3.91	15.88	15.8	39.36	0.013
5/16	7.92	19.05	1.984	10.16	16.256	NTA-512	5.83	13.17	1.30	24000	0.002	TRA-512	7.92	19.05	0.81	0.76	7.92	7.85	19.84	0.001
												TRB-512	7.92	19.05	1.60	1.52	7.92	7.85	19.84	0.003
3/4	19.05	31.75	1.9837	21.34	28.956	NTA-1220	10.90	36.48	3.40	14000	0.004	TRA-1220	19.05	31.75	0.81	0.76	19.05	18.97	32.54	0.003
												TRB-1220	19.05	31.75	1.60	1.52	19.05	18.97	32.54	0.006
												TRC-1220	19.05	31.75	2.41	2.34	19.05	18.97	32.54	0.010
												TRD-1220	19.05	31.75	3.20	3.12	19.05	18.97	32.54	0.012
												TRE-1220	19.05	31.75	3.99	3.91	19.05	18.97	32.54	0.015
7/8	22.23	36.50	1.984	24.38	33.782	NTA-1423	13.43	49.82	4.65	12000	0.005	TRA-1423	22.23	36.50	0.81	0.76	22.23	22.15	37.31	0.004
												TRB-1423	22.23	36.50	1.60	1.52	22.23	22.15	37.31	0.008

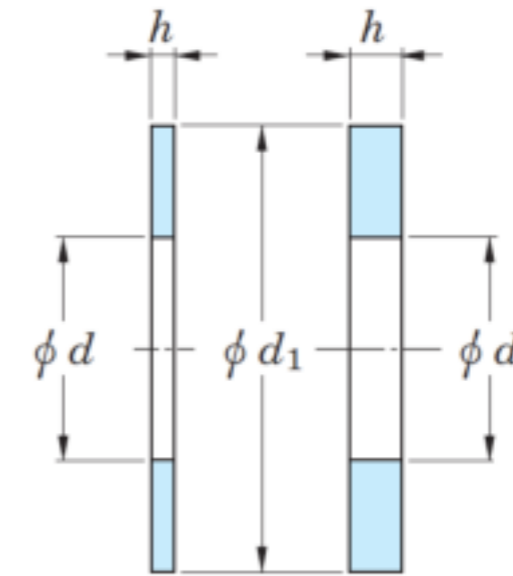
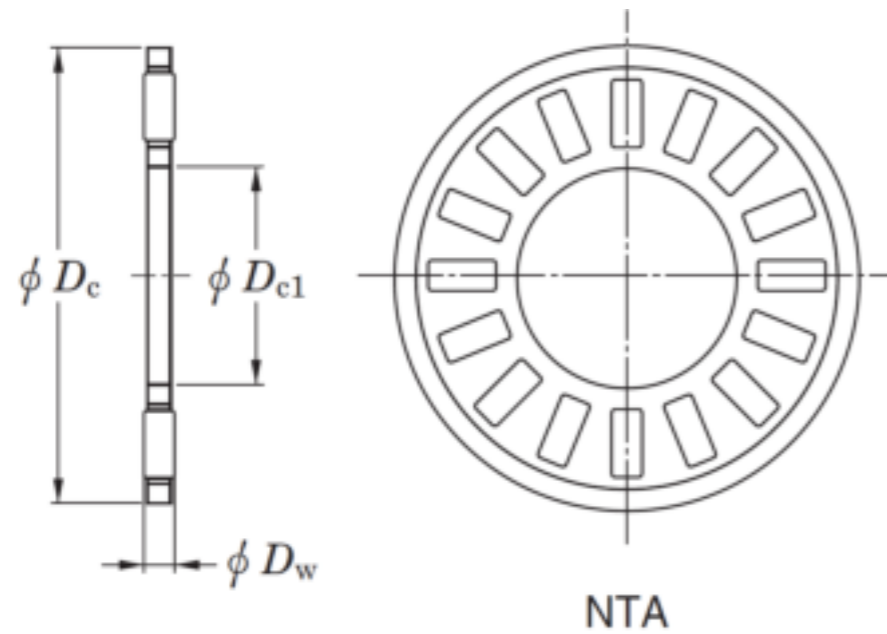

shaft dia. (inch)	Dc1	Dc	Dw	Ea	Eb	Bearing no.	Basic load ratings (kN)		Fatigue Load limit (kN) Cu	Limiting speed (min-1)	Mass (kg)	Washer No.	Washer Dimensions mm				Piloting dimensions(mm)		Dia. to clear O.D.(mm)	Washer mass (kg)	
							Cr	Cor					TRA Washers	d	d1	h		S			
																max.	min.	max.			min.
1	25.40	39.675	1.984	27.69	36.83	NTA-1625	13.83	53.82	5.00	11000	0.006	TRA-1625	25.40	39.67	0.81	0.76	25.40	25.32	40.49	0.005	
												TRB-1625	25.40	39.67	1.60	1.52	25.40	25.32	40.49	0.009	
												TRD-1625	25.40	39.67	3.20	3.12	25.40	25.32	40.49	0.017	
												TRE-1625	25.40	39.67	3.99	3.91	25.40	25.32	40.49	0.021	
1 1/8	28.58	44.45	1.9837	30.73	41.656	NTA-1828	16.68	71.17	7.30	9600	0.009	TRA-1828	28.58	44.45	0.81	0.76	28.58	28.50	45.24	0.006	
												TRB-1828	28.58	44.45	1.60	1.52	28.58	28.50	45.24	0.011	
												TRC-1828	28.58	44.45	2.41	2.34	28.58	28.50	45.24	0.017	
												TRD-1828	28.58	44.45	3.20	3.12	28.58	28.50	45.24	0.022	
1 1/4	31.75	49.20	1.9837	34.04	46.228	NTA-2031	20.15	93.41	9.55	8600	0.010	TRA-2031	31.75	49.20	0.81	0.76	31.75	31.67	50.01	0.007	
												TRB-2031	31.75	49.20	1.60	1.52	31.75	31.67	50.01	0.014	
												TRC-2031	31.75	49.20	2.41	2.34	31.75	31.67	50.01	0.020	
												TRD-2031	31.75	49.20	3.20	3.12	31.75	31.67	50.01	0.026	
1 3/8	34.93	52.375	1.9837	37.08	49.53	NTA-2233	21.35	103.20	10.5	8000	0.010	TRA-2233	34.93	52.37	0.81	0.76	34.93	34.85	53.19	0.007	
												TRB-2233	34.93	52.37	1.60	1.52	34.93	34.85	53.19	0.015	
												TRC-2233	34.93	52.37	2.41	2.34	34.93	34.85	53.19	0.018	
												TRD-2233	34.93	52.37	3.20	3.12	34.93	34.85	53.13	0.029	
1 1/2	38.10	55.55	1.9837	40.39	52.578	NTA-2435	23.22	117.88	12.0	7600	0.011	TRA-2435	38.10	55.55	0.81	0.76	38.10	38.02	56.36	0.008	
												TRB-2435	38.10	55.55	1.60	1.52	38.10	38.02	56.36	0.015	
												TRA-2840	44.45	63.50	0.81	0.76	44.45	44.37	64.29	0.010	
												TRB-2840	44.45	63.50	1.60	1.52	44.45	44.37	64.29	0.020	
1 3/4	44.45	63.50	1.984	46.74	58.928	NTA-2840	25.31	137.45	14.0	6800	0.014	TRC-2840	44.45	63.50	2.41	2.34	44.45	44.37	64.29	0.029	
												TRD-2840	44.45	63.50	3.20	3.12	44.45	44.37	64.29	0.038	
												TRA-2840	44.45	63.50	4.78	4.70	44.45	44.37	64.29	0.057	

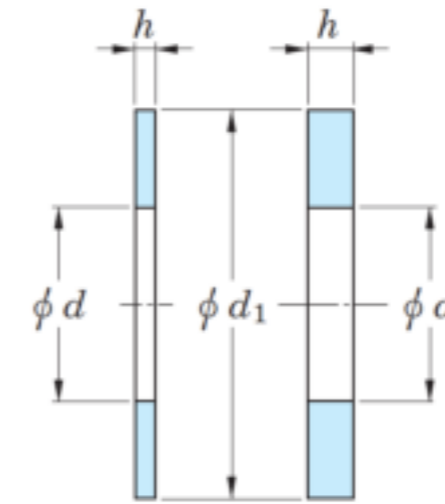
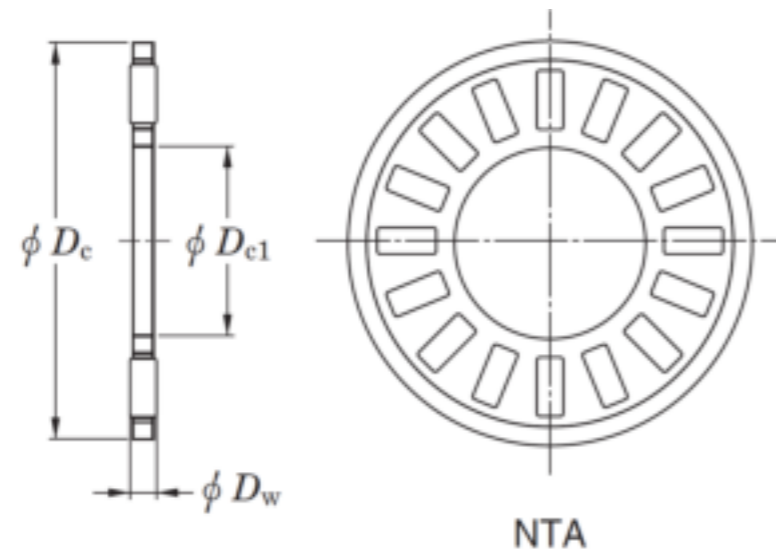

shaft dia. (inch)	Dc1	Dc	Dw	Ea	Eb	Bearing no.	Basic load ratings (kN)		Fatigue Load limit (kN) Cu	Limiting speed (min-1)	Mass (kg)	Washer No.	Washer Dimensions mm				Piloting dimensions(mm)		Dia. to clear O.D.(mm)	Washer mass (kg)
							Cr	Cor					d	d1	h		S			
															max.	min.	max.	min.		
2	50.80	69.85	1.9837	53.09	65.278	NTA-3244	24.02	132.56	13.5	6100	0.015	TRA-3244	50.80	69.85	0.81	0.76	50.80	50.72	70.64	0.011
												TRB-3244	50.80	69.85	1.60	1.52	50.80	50.72	70.64	0.022
												TRC-3244	50.80	69.85	2.41	2.34	50.80	50.72	70.64	0.033
												TRD-3244	50.80	69.85	3.20	3.12	50.80	50.72	70.64	0.044
												TRF-3244	50.80	69.85	4.78	4.70	50.80	50.72	70.64	0.066
2 1/8	53.98	73.025	1.984	56.39	68.58	NTA-3446	24.42	137.45	14.0	5800	0.016	TRA-3446	53.98	73.03	0.81	0.76	53.98	53.90	73.81	0.012
												TRB-3446	53.98	73.03	1.60	1.52	53.98	53.90	73.81	0.024
												TRC-3446	53.98	73.03	2.41	2.34	53.98	53.90	73.81	0.035
												TRD-3446	53.98	73.03	3.20	3.12	53.98	53.90	73.81	0.047
2 1/4	57.15	76.20	1.984	59.44	71.628	NTA-3648	24.78	142.34	14.6	5600	0.017	TRA-3648	57.15	76.20	0.81	0.76	57.15	57.07	76.99	0.012
												TRB-3648	57.15	76.20	1.60	1.52	57.15	57.07	76.99	0.022
												TRC-3648	57.15	76.20	2.41	2.34	57.15	57.07	76.99	0.037
												TRD-3648	57.15	76.20	3.20	3.12	57.15	57.07	76.99	0.048
												TRF-3648	57.15	76.20	4.78	4.70	57.15	57.07	76.99	0.071
2 1/4	57.15	79.375	3.175	59.94	75.184	NTA-3650	37.68	177.04	18.6	5300	0.029	TRC-3650	57.15	79.38	2.41	2.34	57.15	57.07	76.99	-
2 1/2	63.50	82.55	1.9837	65.79	77.978	NTA-4052	25.52	152.13	15.6	5100	0.019	TRA-4052	63.50	82.55	0.81	0.76	63.50	63.42	83.34	0.013
												TRB-4052	63.50	82.55	1.60	1.52	63.50	63.42	83.34	0.027
												TRC-4052	63.50	82.55	2.41	2.34	63.50	63.42	83.34	0.041
2 3/4	69.85	92.075	3.175	72.64	87.884	NTA-4458	47.60	255.8	26.8	4600	0.037	TRA-4458	69.85	92.08	0.81	0.76	69.85	69.77	92.86	0.018
												TRB-4458	69.85	92.08	1.60	1.52	69.85	69.77	92.86	0.035
												TRC-4458	69.85	92.08	2.41	2.34	69.85	69.77	92.86	0.051
												TRD-4458	69.85	92.08	3.20	3.12	69.85	69.77	92.86	0.069
												TRF-4458	69.85	92.08	4.78	4.70	69.85	69.77	92.86	0.104
3	76.20	95.25	1.9837	78.49	90.678	NTA-4860	26.96	172.1	17.6	4400	0.022	TRA-4860	76.20	95.25	0.81	0.76	76.20	76.12	96.04	0.015
												TRB-4860	76.20	95.25	1.60	1.52	76.20	76.12	96.04	0.032
												TRD-4860	76.20	95.25	3.20	3.12	76.20	76.12	96.04	0.061
3 1/4	82.55	104.78	3.175	85.34	100.58	NTA-5266	51.60	294.9	30.9	4000	0.042	TRA-5266	82.55	104.78	0.81	0.76	82.55	82.47	105.56	0.020
												TRD-5266	82.55	104.78	3.20	3.12	82.55	82.47	105.66	0.080

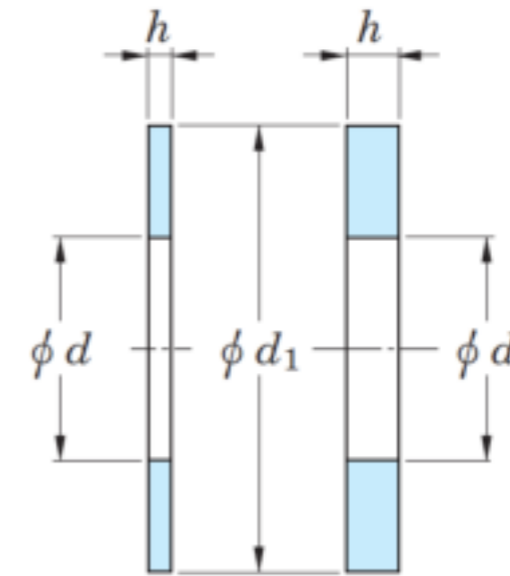
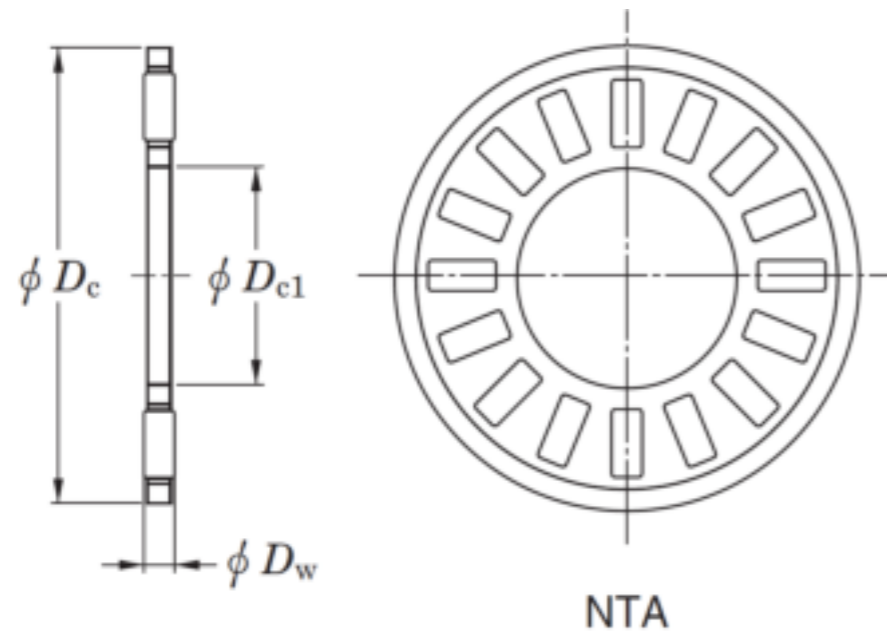

shaft dia. (inch)	Dc1	Dc	Dw	Ea	Eb	Bearing no.	Basic load ratings (kN)		Fatigue Load limit (kN) Cu	Limiting speed (min-1)	Mass (kg)	Washer No.	Washer Dimensions mm				Piloting dimensions(mm)		Dia. to clear O.D.(mm)	Washer mass (kg)
							Cr	Cor					d	d1	h		S			
											TRA Washers			max.	min.	max.	min.	H 2)		
3 3/4	95.25	117.48	3.175	98.04	113.28	NTA-6074	56.05	344.3	35.5	3500	0.050	TRA-6074	95.25	117.48	0.81	0.76	95.25	95.17	118.26	0.023
												TRB-6074	95.25	117.48	1.60	1.52	95.25	95.17	118.26	0.046
												TRC-6074	95.25	117.48	2.41	2.34	95.25	95.17	118.26	0.069
												TRD-6074	95.25	117.48	3.20	3.12	95.25	95.17	118.26	0.092
4 1/8	104.78	125.57	3.175	107.44	124.46	NTA-6681	63.61	414.6	41.3	3200	0.062	TRA-6681	104.78	128.57	0.81	0.76	104.78	104.70	129.39	0.027
												TRC-6681	104.78	128.57	2.41	2.34	104.78	104.70	129.39	0.081
												TRD-6681	104.78	128.57	3.20	3.12	104.78	104.70	129.39	0.109
												TRF-6681	104.78	128.57	4.78	4.70	104.78	104.70	129.39	0.161

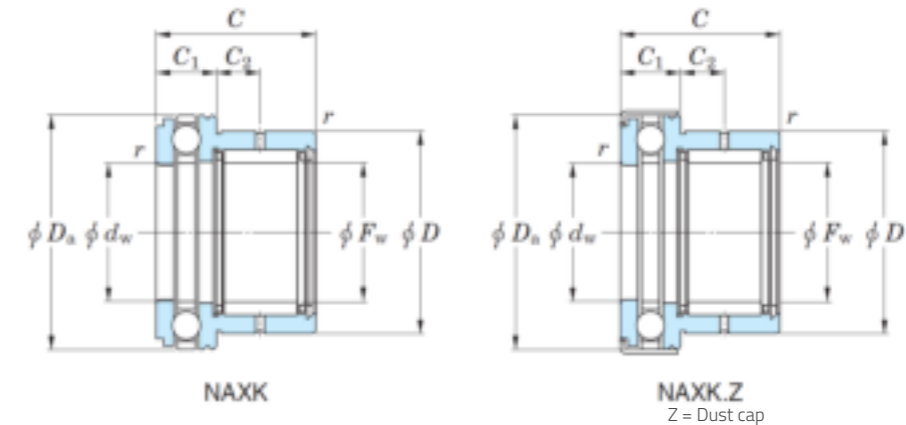
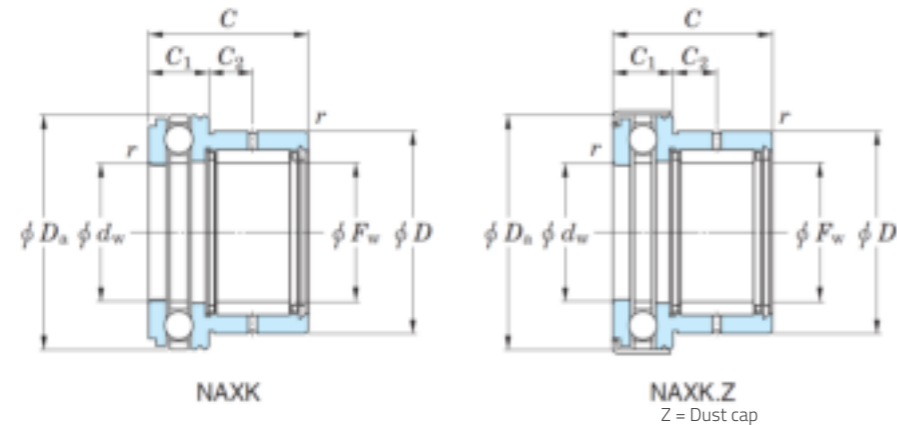

Shaftdia.	Boundary dimensions(mm)								Limiting speed(min-1)	Basic load ratings				Fatigue load limits(kN)		Mass(kg)	Matching inner ring No.		
	Fw	D	C	dw	Da	C1	C2	r min.		Bearing No.	Oil lub.	Radial		Thrust				Cu	
												Cr	COr	Ca	COa			Radial	Thrust
10	10	19	23	10	25	9	6.5	0.3	NAXK10Z	9 500	7.9	8.7	10.4	14	1.35	0.63	0.04	JR7x10x16	
	10	19	23	10	24	9	6.5	0.3	NAXK10	9 500	7.9	8.7	10.4	14	1.35	0.63	0.04	JR7x10x16	
12	12	21	23	12	27	9	6.5	0.3	NAXK12Z	9 000	7.5	8.5	10.7	15.4	1.3	0.69	0.047	JR9x12x16	
	12	21	23	12	26	9	6.5	0.3	NAXK12	9 000	7.5	8.5	10.7	15.4	1.3	0.69	0.046	JR9x12x16	
15	15	24	23	15	29	9	6.5	0.3	NAXK15Z	8 500	9.7	12.6	10.9	16.8	1.9	0.76	0.05	JR12x15x16	
	15	24	23	15	28	9	6.5	0.3	NAXK15	8 500	9.7	12.6	10.9	16.8	1.9	0.76	0.047	JR12x15x16	
17	17	26	25	17	31	9	8	0.3	NAXK17Z	8 500	11.4	16.1	11.8	19.6	2.5	0.88	0.064	JR14x17x17	
	17	26	25	17	30	9	8	0.3	NAXK17	8 500	11.4	16.1	11.8	19.6	2.5	0.88	0.06	JR14x17x17	
20	20	30	30	20	36	10	10.5	0.3	NAXK20Z	7 000	14.8	23.7	15.5	26.6	3.65	1.2	0.094	JR17x20x20	
	20	30	30	20	36	10	10.5	0.3	NAXK20	7 000	14.8	23.7	15.5	26.6	3.65	1.2	0.089	JR17x20x20	
25	25	37	30	25	43	11	9.5	0.6	NAXK25Z	6 300	18.8	29.8	18.8	35.5	4.6	1.6	0.141	JR20x25x20	
	25	37	30	25	42	11	9.5	0.6	NAXK25	6 300	18.8	29.8	18.8	35.5	4.6	1.6	0.134	JR20x25x20	
30	30	42	30	30	48	11	9.5	0.6	NAXK30Z	5 600	20.2	34.6	19.5	39.9	5.35	2.15	0.154	JR25x30x20	
	30	42	30	30	47	11	9.5	0.6	NAXK30	5 600	20.2	34.6	19.5	39.9	5.35	2.15	0.146	JR25x30x20	
35	35	47	30	35	53	12	9	0.6	NAXK35Z	5 300	22.1	40.8	20.8	46.6	6.35	2.1	0.184	JR30x35x20	
	35	47	30	35	52	12	9	0.6	NAXK35	5 300	22.1	40.8	46.6	46.6	6.35	2.1	0.176	JR30x35x20	
40	40	52	32	40	61	13	10	0.6	NAXK40Z	4 500	23.8	47	28	62.9	7.3	2.85	0.233	JR35x40x20	
	40	52	32	40	60	13	10	0.6	NAXK40	4 500	23.8	47	28	62.9	7.3	2.85	0.224	JR35x40x20	
45	45	58	32	45	66.5	14	9	0.6	NAXK45Z	4 500	24.9	51.8	29	69.2	8.05	3.1	0.275	JR40x45x20	
	45	58	32	45	65	14	9	0.6	NAXK45	4 500	24.9	51.8	29	69.2	8.05	3.1	0.262	JR40x45x20	
50	50	62	35	50	71.5	14	10	0.6	NAXK50Z	4 300	30.2	68.5	29.9	75.5	10.7	3.4	0.332	JR45x50x25	
	50	62	35	50	70	14	10	0.6	NAXK50	4 300	30.2	68.5	29.9	75.5	10.7	3.4	0.316	JR45x50x25	
60	60	72	40	60	85	17	12	1	NAXK60	3 600	31.9	78.1	43	113	12.2	5.1	0.48	JR50x60x25	
70	70	85	40	70	95	18	11	1	NAXK70	3 400	43.6	87.9	41.6	110	13.9	4.95	0.65	JR60x70x25	

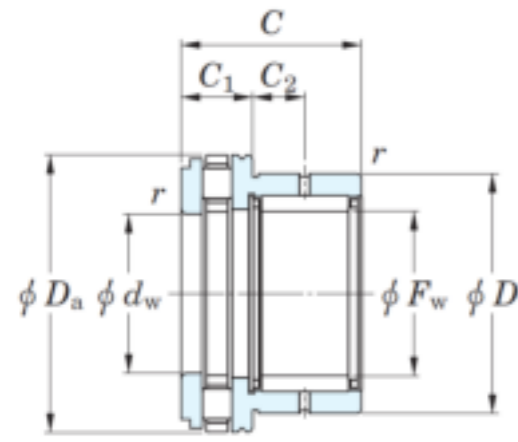

NAXR

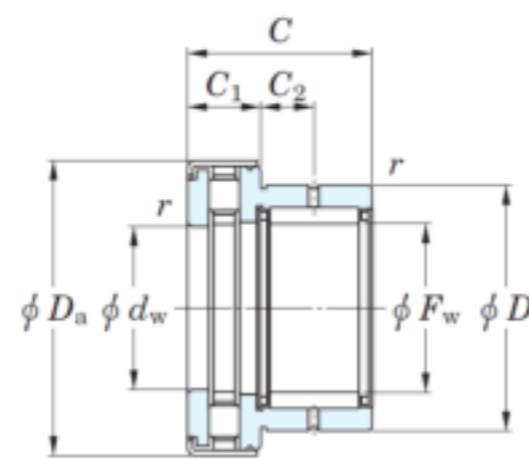

NAXR.Z
Z = Dust cap

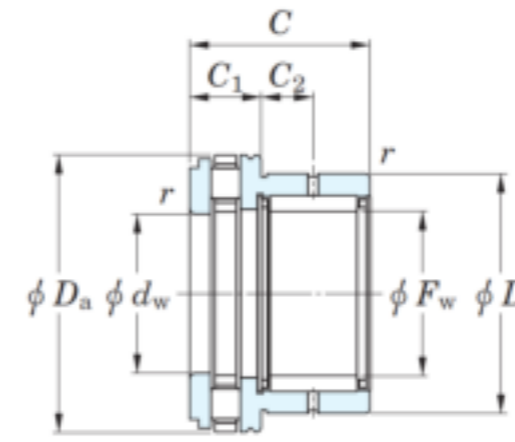

NAXR

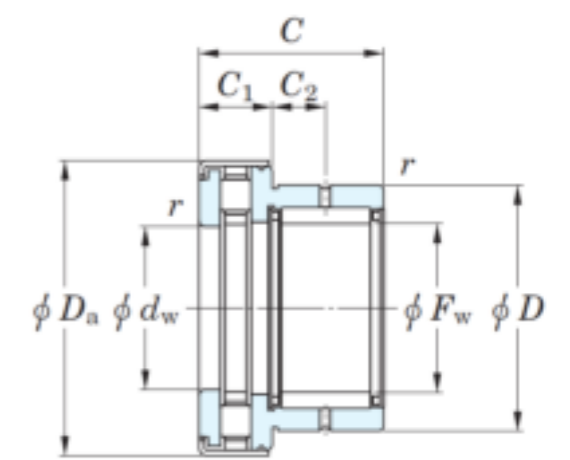

NAXR.Z
Z = Dust cap

Shaft dia.	Boundary dimensions								Bearing No.		Limiting speed(min ⁻¹)	Basic load ratings(kN)				Fatigue load limits(kN)		Mass (kg)	Matching inner ring No.
	Fw	D	C	dw	Da	C1	C2	r min.	NAXR	NAXR.Z		Radial		Thrust		Cu			
												Cr	COr	Ca	COa	Radial	Thrust		
15	15	24	23	15	29	9	6.5	0.3	-	NAXR15.Z	12 000	9.7	12.6	12.1	26.3	2.3	3.7	0.035	JR12x15x16
17	17	26	25	17	31	9	8	0.3	-	NAXR17.Z	11 000	11.4	16.1	12.6	28.6	2.7	4.05	0.053	JR14x17x17
	17	26	25	17	30	9	8	0.3	NAXR17	-		11.4	16.1	12.6	28.6	2.7	4.05	0.05	JR14x17x17
20	20	30	30	20	36	10	10.5	0.3	-	NAXR20Z.TN	9 500	14.8	23.7	23.6	56.8	4	8	0.095	JR17x20x20
	20	30	30	20	35	10	10.5	0.3	NAXR20TN	-		14.8	23.7	23.6	56.8	4	8	0.09	JR17x20x20
25	25	37	30	25	42	11	9.5	0.6	-	NAXR25Z.TN	8 000	18.8	29.8	31.2	81	4.8	11.4	0.146	JR20x25x20
	25	37	30	25	42	11	9.5	0.6	NAXR25TN	-		18.8	29.8	31.2	81	4.8	11.4	0.152	JR20x25x20
30	30	42	30	30	48	11	9.5	0.6	-	NAXR30Z.TN	6 700	20.2	34.6	33	91.1	6.1	12.8	0.169	JR25x30x20
	30	42	30	30	47	11	9.5	0.6	NAXR30TN	-		20.2	34.6	33	91.1	6.1	12.8	0.162	JR25x30x20
35	35	47	30	35	53	12	9	0.6	-	NAXR35.Z	6 000	22.1	40.8	30.9	86	7.05	12.1	0.195	JR30x35x20
	35	47	30	35	52	12	9	0.6	NAXR35	-		22.1	40.8	30.9	86	7.05	12.1	0.186	JR30x35x20
40	40	52	32	40	61	13	10	0.6	-	NAXR40.Z	5 300	23.8	47	44.5	126	8.05	12	0.299	JR35x40x20
50	50	62	35	50	71	14	10	0.6	-	NAXR50.Z	4 300	30.2	68.5	49.7	155	12.5	14.8	0.452	JR45x50x25
	50	62	35	50	70	14	10	0.6	NAXR50	-		30.2	68.5	49.7	155	12.5	14.8	0.452	JR45x50x25

Machined Type without Inner Ring

NK Series - Metric

Koyo

Finer Power Transmissions P/L | www.finerpt.com

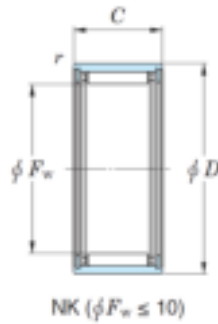

Shaft dia.	Boundary dimensions(mm)			Bearing No.	Basic load ratings(kN)		Fatigue load limit(kN)	Limiting speeds(min-1)		Mass(kg)
	Fw	D	C		Cr	COr		Cu	Grease lub.	
8	8	15	12	NK8/12	4.57	4.89	0.74	26 000	41 000	0.011
	8	15	16	NK8/16	5.22	5.78	0.88	26 000	41 000	0.013
10	10	17	12	NK10/12	5.4	6.43	0.980	25000	39000	0.015
	10	17	16	NK10/16TN	5.3	6.27	0.94	25 000	39 000	0.015
12	12	19	12	NK12/12	6.86	7.6	1.15	19 000	30 000	0.013
	12	19	16	NK12/16	6.78	9.03	1.4	24 000	37 000	0.018
14	14	22	16	NK14/16	12.4	14.8	2.25	16 000	24 000	0.023
	14	22	20	NK14/20	14.7	18.4	2.9	16 000	24 000	0.028
15	15	23	16	NK15/16	12.4	15	2.3	15000	24000	0.024
	15	23	20	NK15/20	14.7	18.6	2.95	15 000	24 000	0.031
16	16	24	16	NK16/16	15.4	20.2	2.5	18 000	28 000	0.025
	16	24	20	NK16/20	16.1	21.3	3.2	18000	28000	0.036
17	17	25	16	NK17/16	13.6	17.5	2.7	17000	27000	0.027
	17	25	20	NK17/20	15.4	20.4	3.25	17000	27000	0.034
18	18	26	16	NK18/16	13.6	17.7	2.7	16 000	25 000	0.028
19	19	27	16	NK19/16	14.1	19	2.9	15 000	24 000	0.029
20	20	28	16	NK20/16	14.1	19.1	2.9	14 000	22 000	0.03
	20	28	20	NK20/20	17.5	25.3	4	14 000	22 000	0.038
21	21	29	16	NK21/16	15.3	21.6	3.3	14000	21000	0.032
	21	29	20	NK21/20	18.1	26.9	4.25	14000	21000	0.040
22	22	30	16	NK22/16	15.2	21.7	3.3	13 000	20 000	0.033
	22	30	20	NK22/20	18	27	4.3	13 000	20 000	0.041
24	24	32	16	NK24/16	16.2	24.3	3.7	12 00	12 000	0.035
	24	32	20	NK24/20	19.3	30.3	4.8	12 000	18 000	0.045
25	25	33	16	NK25/16	16.1	24.4	3.75	11 000	17 000	0.037
	25	33	20	NK25/20	19.1	30.4	30.4	11 000	17 000	0.047
26	26	34	16	NK26/16	16.6	25.7	3.95	11 000	17 000	0.039
	26	34	20	NK26/20	19.7	32	5.05	11 000	17 000	0.048
28	28	37	20	NK28/20	22.6	34.4	5.5	10 000	16 000	0.057
	28	37	30	NK28/30	29	53.8	8.3	10 000	16 000	0.088
29	29	38	20	NK29/20	23.4	36.4	5.8	9 800	15 000	0.059
	29	38	30	NK29/30	29.8	56.4	8.7	9 700	15 000	0.09
30	30	40	20	NK30/20	24.2	38.3	6.1	9 500	15 000	0.071
	30	40	30	NK30/30	34.7	61	9.45	9 500	15 000	0.107
32	32	42	20	NK32/20	24.8	40.4	6.45	8 800	14 000	0.074
	32	42	30	NK32/30	35.6	64.3	9.95	8 800	14 000	0.112
35	35	45	20	NK35/20	26.1	44.4	7.05	8 000	12 000	0.081
	35	45	30	NK35/30	37.4	70.6	11	8 000	12 000	0.122
37	37	47	30	NK37/30	38.2	73.9	11.5	7 600	12 000	0.128
40	40	50	20	NK40/20	27.8	50.4	8.05	7000	11000	0.089
	40	50	30	NK40/30	40	80.2	12.4	7000	11000	0.137

TN = Poly Cage

Every effort has been taken to ensure that the data listed in this catalogue is correct. Finer Power Transmissions P/L will not accept liability for any damage or loss caused as a result of the data in this catalogue.

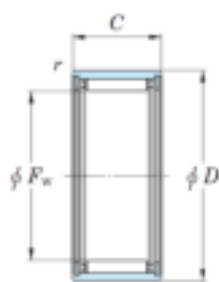
 NK ($\phi F_w \leq 10$)

Shaft dia.	Boundary dimensions(mm)			Bearing No.	Basic load ratings(kN)		Fatigue load limit(kN)	Limiting speeds(min-1)		Mass(kg)
	Fw	D	C		Cr	C0r	Cu	Grease lub.	Oil lub.	
42	42	52	20	NK42/20	28.3	52.4	8.35	6600	10000	0.085
	42	52	30	NK42/30	40.7	83.5	13.5	6600	10000	0.141
	42	52	30	NK42/30	40.7	83.5	13	6 600	10 000	0.141
45	45	55	20	NK45/20	29.5	56.4	9	6100	9400	0.100
	45	55	30	NK45/30	42.3	89.8	13.9	6100	9400	0.151
47	47	57	20	NK47/20	30	58.5	9.3	5900	9000	0.104
50	50	62	25	NK50/25	40.7	79.3	12.5	5500	8500	0.171
55	55	68	35	NK55/35	62.3	129	20	5000	7800	0.293
60	60	72	25	NK60/25	44.3	94	14.9	4400	7000	0.202
	60	72	35	NK60/35	59.9	139	21.5	4400	7000	0.286
65	65	78	35	NK65/35	65.2	144	22.4	4 200	6 500	0.298
70	70	85	25	NK70/25	43.6	87.9	16.6	3 900	6 000	0.298
75	75	92	25	NK75/25	43.7	90.2	19	3 600	5 600	0.364
80	80	95	35	NK80/35	79.7	184	28.7	3400	5300	0.380
85	85	105	25	NK85/25	76.4	137	22.2	3 300	5 000	0.506
	85	105	35	NK85/35	108	214	34.7	3 300	5 000	0.61
90	90	110	25	NK90/25	79.5	147	23.8	3100	4700	0.450
100	100	120	26	NK100/26	83.6	163	25.8	2 800	4 200	0.53
	100	120	36	NK100/36	118	254	39.1	2 800	4 200	0.658
110	110	130	30	NK110/30	103	220	33.6	2 500	3 800	0.66
	110	130	40	NK110/40	132	301	45.7	2 500	3 800	0.9

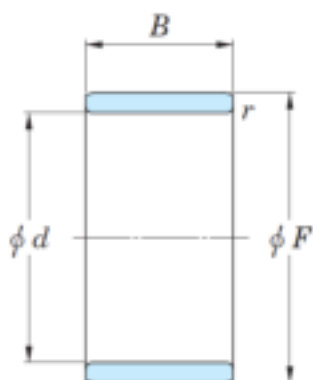
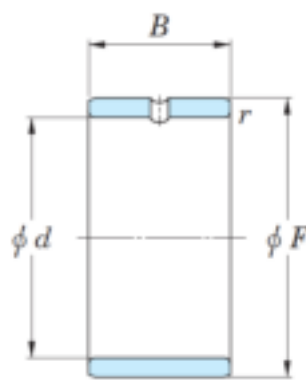

JR, IM..P

JR.JS1

Shaft dia.	Boundary dimensions(mm)			Part No.	Mass
	d	F	B		
7	7	10	16	JR7x10x16	0.005
9	9	12	16	JR9x12x16	0.006
12	12	15	16	JR12x15x16	0.008
14	14	17	17	JR14x17x17	0.009
17	17	20	20	JR17x20x20	0.014
20	20	25	20	JR20x25x20	0.028
25	25	30	20	JR25x30x20	0.034
30	30	35	20	JR30x35x20	0.039
35	35	40	20	JR35x40x20	0.046
40	40	45	20	JR40x45x20	0.052
45	45	50	25	JR45x50x25	0.073
50	50	60	25	JR50x60x25	0.17

Machined Type Heavy Duty without Inner Ring NKS (Metric without Inner Ring) Series

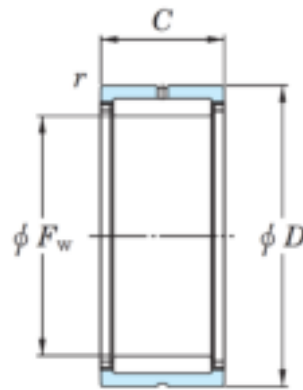

Finer Power Transmissions P/L | www.finerpt.com



Shaft dia.	Boundary dimensions(mm)				Bearing No.	Basic load ratings(kN)		Fatigue load limit(kN)	Limiting speeds(min-1)		Mass (kg)
	Fw	D	C	r min		Cr	COr		Cu	Grease lub	
25	25	38	20	0.6	NKS25	29.1	33	5.3	12 000	19 000	0.076
28	28	42	20	0.6	NKS28	30.3	38.4	6.15	11 000	16 000	0.094
30	30	45	20	0.6	NKS30	34.3	42.8	6.85	9 900	15 000	0.114
32	32	47	22	0.6	NKS32	36	46.2	7.4	9 200	14 000	0.12
35	35	50	22	0.6	NKS35	37.5	49.9	8	8 400	13 000	0.13
37	37	52	22	0.6	NKS37	39	53.4	8.55	7 900	12 000	0.134
40	40	55	22	0.6	NKS40	40.3	57	9.15	7 200	11 000	0.14
45	45	60	22	0.6	NKS45	43	64.2	10.3	6 400	9 800	0.156
50	50	65	22	1	NKS50	45.5	71.3	11.4	5 700	8 700	0.17
55	55	72	22	1	NKS55	47.9	78.4	12.6	5 100	7 900	0.225
60	60	80	28	1.1	NKS60	66.9	103	16.5	4 800	7 300	0.337
75	75	95	28	1.1	NKS75	76.5	132	21.1	3 700	5 800	0.413

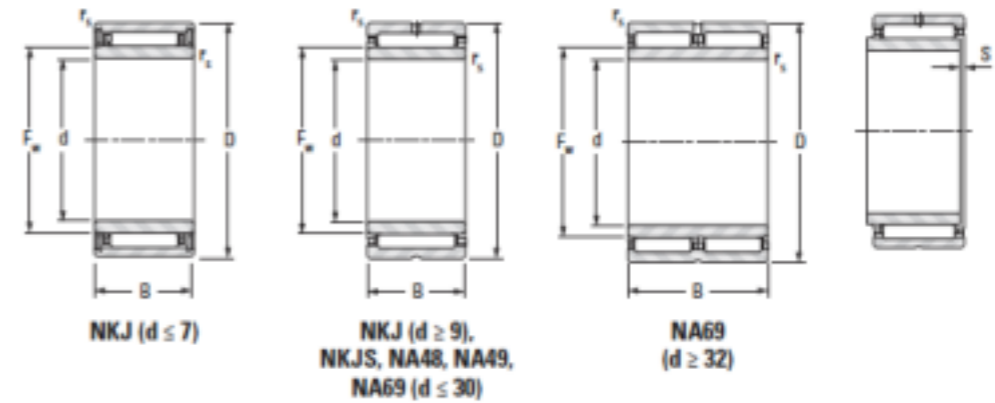
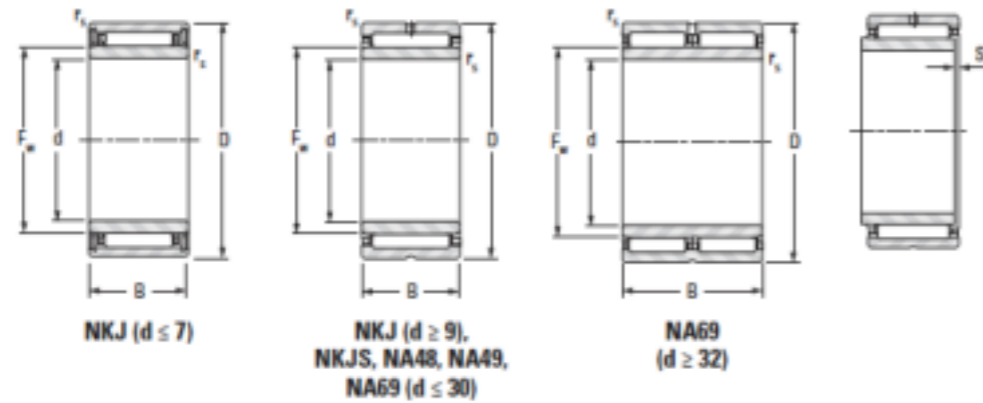

Shaft Dia.	Boundary dimensions(mm)						Bearing No. NKJ-A*	Basic load ratings(kN)		Fatigue load limit(kN)	Limiting speeds(min-1)		Mass(kg)
	d	D	B	Fw	rs min	s		Cr	COR	Cu	Grease	Oil	
6	6	16	16	9	0.3	1.5	NKJ6/16	5.57	6.47	0.980	26000	40000	0.019
7	7	17	12	10	0.3	1.5	NKJ7/12	5.4	6.43	0.980	25000	39000	0.017
7	7	17	16	10	0.3	1.5	NKJ7/16TN	5.3	6.27	0.940	25000	39000	0.021
9	9	19	12	12	0.3	1.5	NKJ9/12	6.86	7.6	1.15	19000	30000	0.018
9	9	19	16	12	0.3	1.5	NKJ9/16	6.78	9.03	1.40	19000	30000	0.024
10	10	22	16	14	0.3	1.5	NKJ10/16	12.4	14.8	2.1	16000	24000	0.032
10	10	22	20	14	0.3	1.5	NKJ10/20	14.7	18.4	2.75	16000	24000	0.04
12	12	24	16	16	0.3	1.5	NKJ12/16	13	16.2	2.50	18000	28000	0.036
12	12	24	20	16	0.3	1.5	NKJ12/20	15.4	20.2	3.20	18000	28000	0.046
15	15	27	16	19	0.3	1.5	NKJ15/16	14.1	19	2.90	15000	24000	0.042
15	15	27	20	19	0.3	1.5	NKJ15/20	16.8	23.6	3.75	15000	24000	0.054
17	17	29	16	21	0.3	2	NKJ17/16	15.3	21.6	3.30	14000	21000	0.047
17	17	29	20	21	0.3	1.5	NKJ17/20	18.1	26.9	4.80	14000	21000	0.059
20	20	32	16	24	0.3	1.5	NKJ20/16	16.2	24.3	3.70	12000	18000	0.053
20	20	32	20	24	0.3	1.5	NKJ20/20	19.3	30.3	4.80	12000	18000	0.067
22	22	34	16	26	0.3	1.5	NKJ22/16	16.6	25.7	3.95	11000	17000	0.058
22	22	34	20	26	0.3	2	NKJ22/20	19.7	32	5.05	11000	17000	0.071
25	25	38	20	29	0.3	2	NKJ25/20	23.4	36.4	5.80	9800	15000	0.086
25	25	38	30	29	0.3	2	NKJ25/30	29.8	56.4	8.70	9800	15000	0.13
28	28	42	20	32	0.3	2	NKJ28/20	24.8	40.4	6.45	8800	14000	0.104
28	28	42	30	32	0.3	2	NKJ28/30	38.9	72.2	11.2	8800	14000	0.156
30	30	45	20	35	0.3	1.5	NKJ30/20	26.1	44.4	7.05	8000	12000	0.12
30	30	45	30	35	0.3	1.5	NKJ30/30	37.4	70.6	11.0	8000	12000	0.179
32	32	47	20	37	0.3	2	NKJ32/20	26.1	45.2	7.05	760	12000	0.127
32	32	47	30	37	0.3	2	NKJ32/30	26.6	46.4	7.20	7600	12000	0.127
32	32	47	30	37	0.3	1.5	NKJ32/30	38.2	73.9	11.5	7600	12000	0.192
35	35	50	20	40	0.3	2	NKJ35/20	27.8	50.4	8.05	7000	11000	0.135
35	35	50	30	40	0.3	1.5	NKJ35/30	40	80.2	12.4	7000	11000	0.208
40	40	55	20	45	0.3	2	NKJ40/20	29.5	56.4	9.00	6100	9400	0.152
40	40	55	30	45	0.3	1.5	NKJ40/30	42.3	89.8	13.9	6100	9400	0.229
42	42	57	20	47	0.3	2	NKJ42/20	30	58.5	9.30	5900	9000	0.159
42	42	57	30	47	0.3	1.5	NKJ42/30	43	93.1	14.4	5900	9000	0.241
45	45	62	25	50	0.6	3	NKJ45/25	40.7	79.3	12.5	5500	8500	0.223
45	45	62	35	50	0.6	3	NKJ45/35	55	117	18.2	5500	8500	0.345
50	50	68	35	55	0.6	3	NKJ50/35	62.3	129	20.0	5000	7800	0.406
55	55	72	35	60	0.6	3	NKJ55/35	59.9	139	21.5	4600	7000	0.41
60	60	82	35	68	0.6	2.5	NKJ60/35	66.2	149	23.2	4000	6200	0.52
65	65	90	25	73	0.6	2	NKJ65/25	61.5	119	19.0	3800	5800	0.5
70	70	95	25	80	1	2	NKJ70/25	66.4	130	20.8	3400	5300	0.561
70	70	95	35	80	1	3.5	NKJ70/35	79.7	184	28.7	3400	5300	0.779
75	75	105	35	85	1	2	NKJ75/35	108	214	33.6	3300	5000	1.05

* Not a stocked range although available on request.

Every effort has been taken to ensure that the data listed in this catalogue is correct. Finer Power Transmissions P/L will not accept liability for any damage or loss caused as a result of the data in this catalogue.

Every effort has been taken to ensure that the data listed in this catalogue is correct. Finer Power Transmissions P/L will not accept liability for any damage or loss caused as a result of the data in this catalogue.

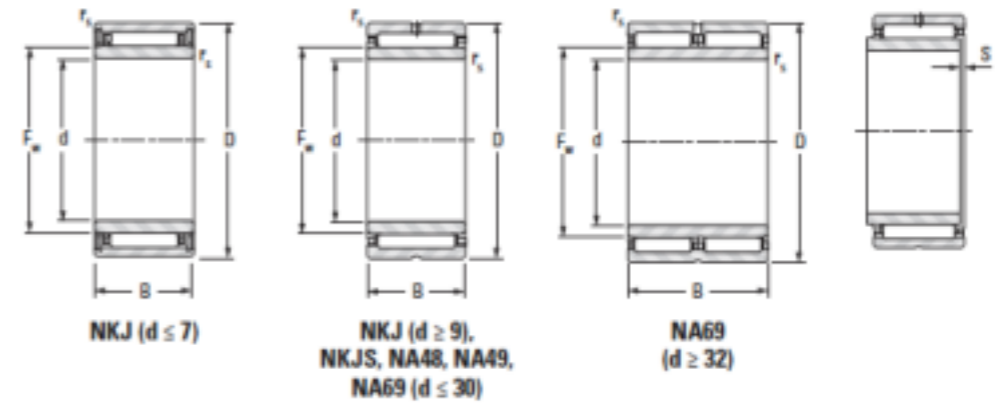
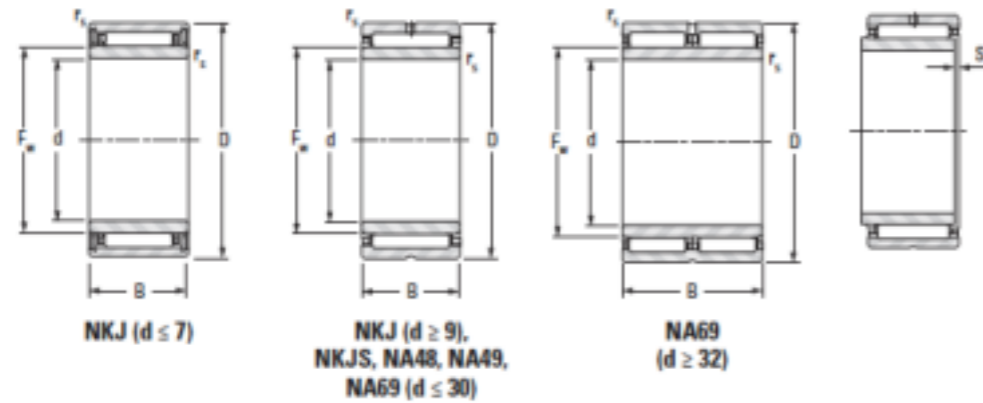

Shaft Dia.	Boundary dimensions(mm)						Bearing No. NKJ-A*	Basic load ratings(kN)		Fatigue load limit(kN)	Limiting speeds(min-1)		Mass(kg)
	d	D	B	Fw	rs min	s		Cr	COR	Cu	Grease	Oil	
80	80	110	25	90	1	2	NKJ80/25	79.5	147	23.8	3100	4700	0.79
85	85	115	26	95	1	3	NKJ85/26	80.7	152	32.8	2800	4400	0.862
85	85	115	36	95	1	2	NKJ85/36	114	238	37.3	2800	4400	1.04
90	90	120	26	100	1	3	NKJ90/26	83.6	163	25.8	2800	4200	0.78
95	95	125	26	105	1	2.5	NKJ95/26	84.7	168	26.3	2600	3900	0.935
100	100	130	30	110	1.1	2	NKJ100/30	103	220	33.6	2500	3800	0.984
100	100	130	40	110	1.1	2	NKJ100/40	130	296	44.8	2500	3800	1.41

* Not a stocked range although available on request.

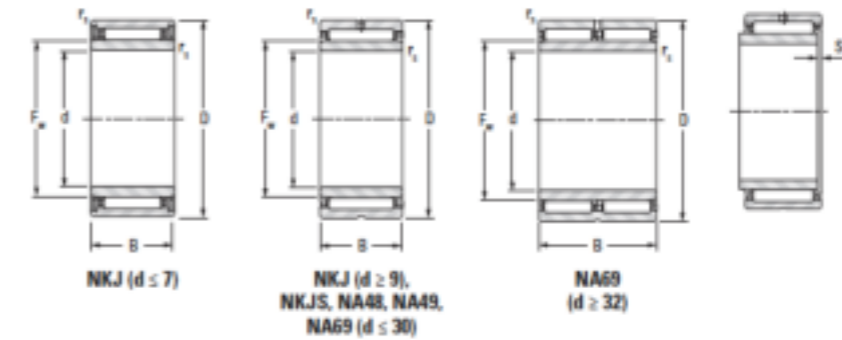
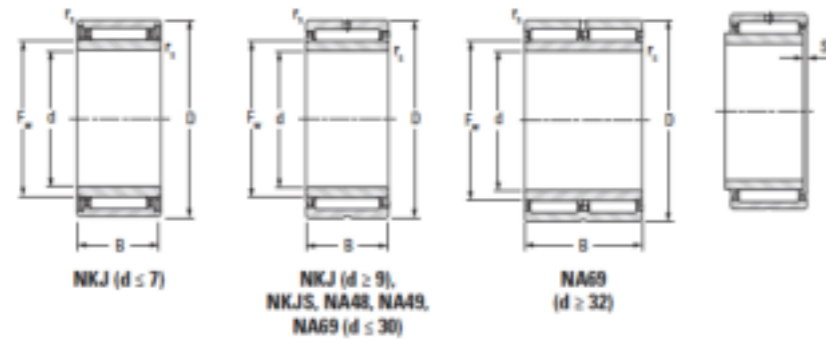

Shaft Dia.	Boundary dimensions(mm)						Bearing No. NKJS-A*	Basic load ratings(kN)		Fatigue load limit(kN) Cu	Limiting speeds(min-1)		Mass(kg)
	d	D	B	Fw	rs min	s		Cr	COR		Grease	Oil	
17	17	37	20	24	0.6	1	NKJS17	29.1	32.8	5.3	13000	20000	0.108
20	20	42	20	28	0.6	1	NKJS20	30.3	38.4	6.15	11000	16000	0.13
25	25	47	22	32	0.6	1.5	NKJS25	36	36.2	7.40	9200	14000	0.174
30	30	52	22	37	0.6	1.5	NKJS30	39	53.4	8.55	7900	12000	0.198
35	35	58	22	43	0.6	1	NKJS35	41.6	60.7	9.75	6700	10000	0.235
40	40	65	22	50	1	1	NKJS40	45.5	71.3	11.4	5700	8700	0.292
45	45	72	22	55	1	1	NKJS45	47.9	78.4	12.6	5100	7900	0.36
50	50	80	28	60	1.1	1.5	NKJS50	66.9	103	16.5	4800	7300	0.523
55	55	85	28	65	1.1	1.5	NKJS55	71	114	18.3	4400	6700	0.569
60	60	90	28	70	1.1	1.5	NKJS60	72.6	120	19.3	4000	6200	0.607
65	65	95	28	75	1.1	1.5	NKJS65	76.5	132	21.1	3700	5800	0.655
70	70	100	28	80	1.1	1.5	NKJS70	80.1	143	22.9	3500	5400	0.772

* Not a stocked range although available on request.

Shaft Dia.	Boundary dimensions(mm)						Bearing No.	Basic load ratings(kN)		Fatigue load limit(kN) Cu	Limiting speeds(min-1)		Mass(kg)
	d	D	B	Fw	rs min	s		Cr	COR		Grease	Oil	
110	110	140	30	120	1	0.5	NA4822	90.3	230	33.7	2300	3500	1.21
140	140	175	35	155	1.1	1	NA4828	116	346	47.1	1700	2700	2.12
22	22	39	17	28	0.3	1.5	NA49/22	23.3	29.6	4.55	10000	16000	0.089

* Not a stocked range although available on request.

Roller Clutch

Drawn Cup Roller Clutch FCB Series

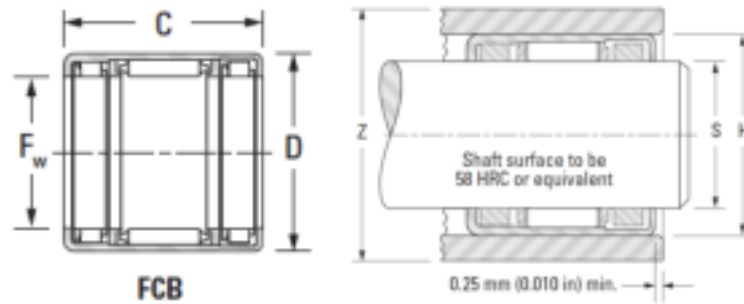

Shaft Dia.	Fw	D	C	Clutch and Bearing Assembly Designation	Torque Rating	Minimum O.D. of Steel Housing of Rated Torque	Load Ratings		Fatigue Load Limit Cu
						Z	Cr	COr	
8	8	14	20	FCB-8	4.42	20	4.22	3.04	0.500
10	10	16	20	FCB-10	5.82	25	4.84	3.80	0.630
12	12	18	26	FCB-12	14.0	27	6.30	5.84	0.970
16	16	22	26	FCB-16	21.7	31	6.64	7.12	1.20
20	20	26	26	FCB-20	32.6	38	8.16	9.46	1.55
25	25	32	30	FCB-25	71.0	46	11.3	13.1	2.20
30	30	37	30	FCB-30	99.1	51	11.5	14.9	2.50

Roller Clutch

Drawn Cup Roller Clutch RCB Series

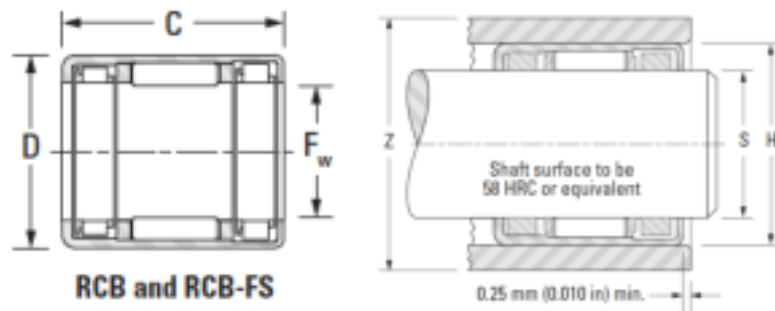

RCB and RCB-FS

Shaft Dia.	Fw	D	C	Clutch and Bearing Assembly Designation		Torque Rating	Minimum O.D. of Steel Housing of Rated Torque	Load Ratings		Fatigue Load Limit Cu
				With Stainless Steel Springs	With Integral Springs			Z	Cr	
9.525	9.53	15.88	22.23	RCB-061014-FS	RCB-061014	5.45	22.4	6.01	4.89	0.800
12.700	12.70	19.05	22.23	RCB-081214-FS	RCB-081214	8.85	27.9	7.12	6.49	1.05
15.875	15.88	22.23	25.40	RCB-101416-FS	RCB-101416	16.8	30.5	8.05	8.14	1.35
19.050	19.05	25.40	25.40	RCB-121616-FS	RCB-121616	23.3	35.6	8.90	9.79	1.60
25.400	25.40	33.35	27.00	RCB-162117-FS	RCB-162117	49.6	48.3	15.4	17.6	2.85

Cam Followers

NUKR Series - Metric

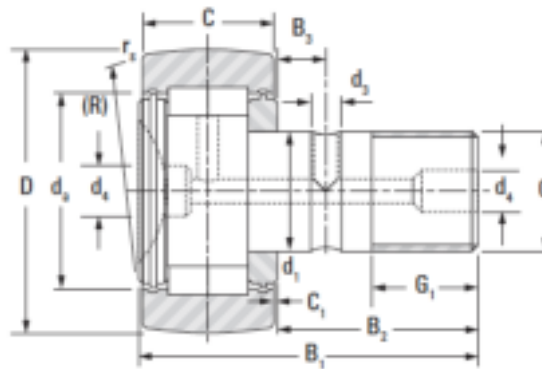

NUKR.2SK

Crowned Designation	Shaft Dia. d1 h7	D	C	Load Ratings					Tightening Torque	Speed Rating Grease	Approx Wt.
				As a Bearing		As a Track Roller					
				Cr	COr	Cw	Fr	FOr			
NUKR35-2SK	16	35	18	24.7	29.4	16.2	10.1	16.1	53.2	6100	0.170
NUKR40-2SK	18	40	20	26.6	33.3	18.7	15.0	23.9	77.5	5300	0.250
NUKR47-2SK	20	47	24	41.4	53.2	28.1	20.5	32.7	109	4500	0.380
NUKR52-2SK	20	52	24	41.4	53.2	28.1	20.5	32.7	109	4500	0.380
NUKR62-2SK	24	62	29	62.7	83.1	40.9	29.6	47.2	193	3200	0.790
NUKR72-2SK	24	72	29	68.9	97.8	46.1	39.6	63.1	193	2600	1.040
NUKR80-2SK	30	80	35	95.4	130	69.74	63.2	101	390	2900	1.550
NUKR90-2SK	30	90	35	95.4	130	77.8	97.8	128	390	2900	2.020

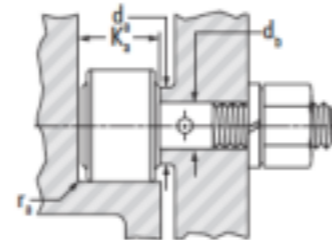
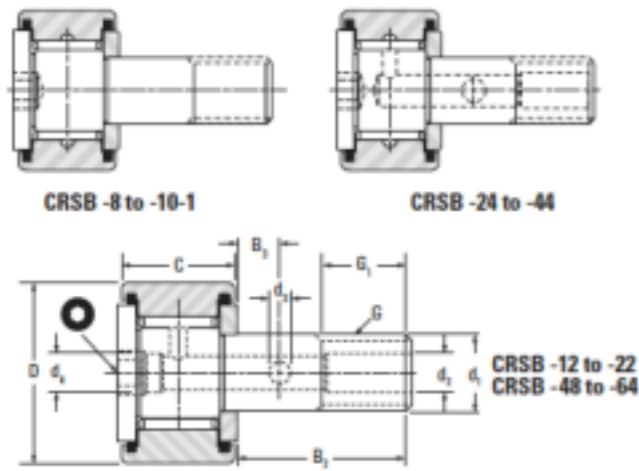

NOTE
Clamping torque is based on lubricated threads. If threads are dry, the torque values listed below may be doubled.

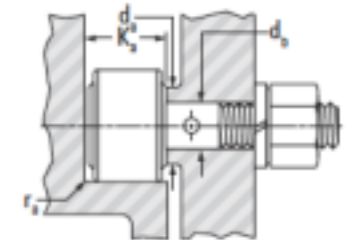
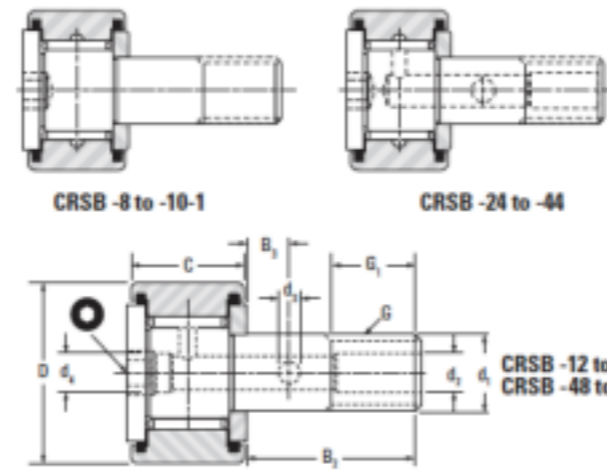

NOTE
Clamping torque is based on lubricated threads. If threads are dry, the torque values listed below may be doubled.

Outer Dia	d1	D	C	B2	B3	G1 Min	d4	d2	d3	G UNF	Bearing No.	Load Rating					Speed Rating Grease	Mounting Dimensions				Clamping Torque	Approx Wt.
												As a Bearing		As a Track Roller				db Bore Dia.	ras Max.	Ka Min.	da Min.		
												Cr kN lbf	COr kN lbf	Cw kN lbf	Fr kN lbf	FOr kN lbf							
3 1/4	31.750	82.55	44.45	63.50	15.88	31.75	6.35	6.35	3.18	1 1/4-12	CRSB-52	74.29	177.93	54.71	85.85	147.24	990	31.750	2.29	46.13	53.98	389.85	2.18
	1.2500	3.250	1.750	2.500	0.625	1.250	0.250	0.250	0.125			16700	40000	12300	19300	33100		1.2500	0.090	1.816	2.125		
3 1/2	34.930	88.90	50.80	69.90	17.48	34.93	6.35	6.35	3.18	1 3/8-12	CRSB-56	109.87	225.52	82.29	94.75	191.27	950	34.925	2.29	52.48	61.93	474.6	2.91
	1.3750	3.500	2.000	2.750	0.688	1.375	0.250	0.250	0.125			24700	50700	18500	21300	43000		1.3750	0.090	2.066	2.438		
4	38.100	101.60	57.15	88.90	19.05	38.10	6.35	6.35	3.18	1 1/2-12	CRSB-64	137.89	319.38	98.75	125.88	250.43	780	38.100	2.29	58.83	71.04	565	4.26
	1.5000	4.000	2.250	3.500	0.750	1.500	0.250	0.250	0.125			31000	71800	22200	28300	56300		1.5000	0.090	2.316	2.797		

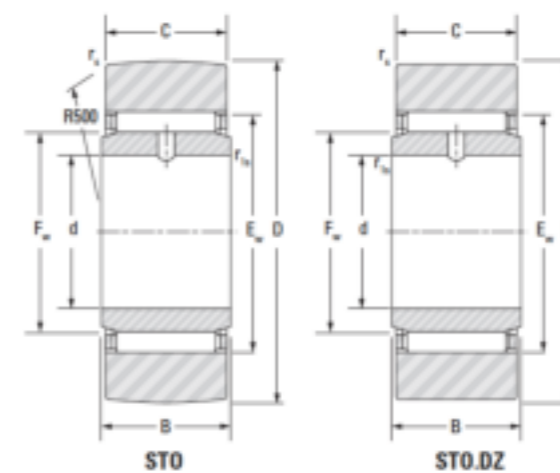
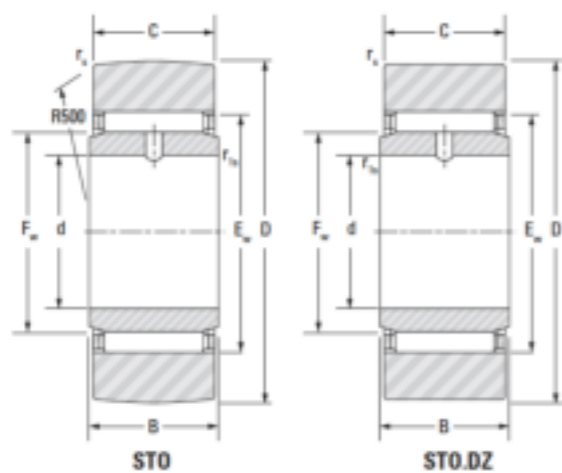

Outer Dia. D	d	B	C	Fw	Ew	rs	r1smin.		Crowned Track Roller	Cylindrical Track Roller	Load Ratings					Speed Rating Grease	Approx. Wt. kg
											As Bearing kN		As a Track Roller kN				
											Cr	Cor	Cw	Fr	FOr		
19	6	10	9.8	10	13	0.3	0.3		ST06	ST06DZ	5.4	6.43	4.15	4.04	5.63	9400	0.018
24	8	10	9.8	12	15	0.3	0.3		ST08	ST08DZ	5.85	7.51	4.79	6.67	7.44	8100	0.028
30	10	12	11.8	14	20	0.3	0.3		ST010	ST010DZ	10.4	10.6	8.62	7.69	10.6	6300	0.065
32	12	12	11.8	16	22	0.3	0.3		ST012	ST012DZ	11.2	11.9	8.8	7.65	10.9	5800	0.114
35	15	12	11.8	20	26	0.3	0.3		ST015	ST015DZ	12.9	15.3	9.13	6.95	11.2	5000	0.065
40	17	16	15.8	22	29	0.3	0.3		ST017	ST017DZ	19.1	23.3	13.8	11.4	18.2	4100	0.114
47	20	16	15.8	25	32	0.3	0.3		ST020	ST020DZ	19.8	25.3	15.3	16.5	22.2	3200	0.16
52	25	16	15.8	30	37	0.3	0.3		ST025	ST025DZ	22.4	31	16	16.9	23.7	2900	0.435
62	30	20	19.8	38	46	0.6	0.6		ST030	ST030DZ	33.3	51	22.3	23.2	34.2	2400	0.325
72	35	20	19.8	42	50	0.6	0.6		ST035	ST035DZ	35.2	56.6	25.2	33.3	43	2200	0.435
80	40	20	19.8	50	58	0.6	1		ST040	ST040DZ	38.8	67.8	25.9	34.7	45	2400	0.54
85	45	20	19.8	55	63	0.6	1		ST045	ST045DZ	40.3	73.5	26	37.1	45.8	2000	0.65
90	50	20	19.8	60	68	0.6	1		ST050	ST050DZ	41.8	79.2	26	37.1	45.8	2000	0.65

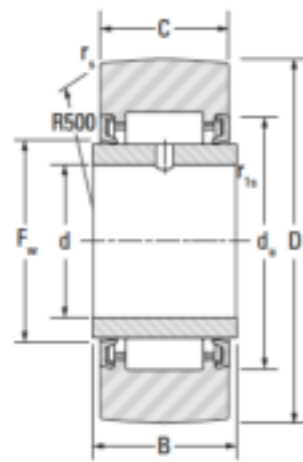

NA22.2RS

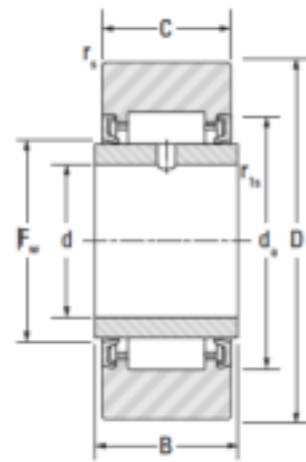

NA22.2RS.DZ

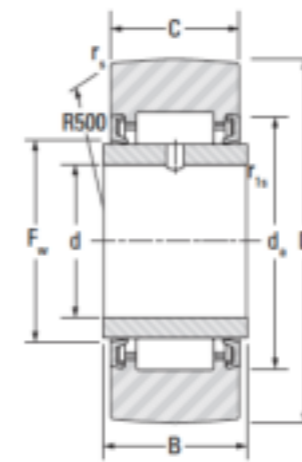

NA22.2RS

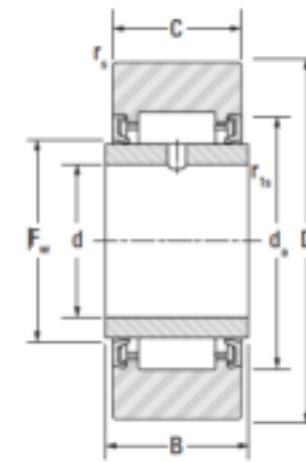

NA22.2RS.DZ

Outer Dia. D	d	B	C	Fw	Ew	rs	r1smin.		Crowned Track Roller	Cylindrical Track Roller	Load Ratings					Speed Rating Grease	Approx. Wt. kg
											As Bearing kN		As a Track Roller kN				
											Cr	Cor	Cw	Fr	FOr		
19	6	12	11.8	10	14	0.3	0.3		NA22/6-2RS	NA22/6-2RS-DZ	4.7	5.43	4.13	3.06	4.59	13000	0.018
24	8	12	11.8	12	18	0.3	0.3		NA22/8-2RS	NA22/8-2RS-DZ	6.7	6.08	5.31	3.37	5.22	11000	0.031
30	10	14	13.8	14	20	0.6	0.3		NA22000-2RS	NA2200-2RS-DZ	8.5	9.45	8.03	7.85	9.45	9400	0.057
32	12	14	13.8	16	22	0.6	0.3		NA2201-2RS	NA2201-2RS-DZ	9	10.5	8.2	7.78	10.1	8100	0.063
35	15	14	13.8	20	27	0.6	0.3		NA2202-2RS	NA2202-2RS-DZ	12.2	14.5	9.24	6	10.2	6300	0.07
40	17	16	15.8	22	30	1	0.3		NA2203-2RS	NA2203-2RS-DZ	16.3	17.8	11.9	8.5	13.7	5900	0.107
47	20	18	17.8	25	35	10	0.3		NA2204-2RS	NA2204-2RS-DZ	19.6	20.2	14.8	11	16.7	5200	0.175
52	25	18	17.8	30	40	1	0.3		NA2205-2RS	NA2205-2RS-DZ	21.6	24.3	15.5	11.3	17.7	4300	0.202
62	30	20	19.8	35	47	1	0.3		NA2206-2RS	NA2206-2RS-DZ	29	32.8	21.2	15.8	24.8	3700	0.324
72	35	23	22.8	42	54	1.1	0.6		NA2007-2RS	NA2007-2RS-DZ	40.5	52.5	28.6	24.2	37.9	3000	0.49
80	40	23	22.8	48	60	1.1	0.6		NA2208-2RS	NA2208-2RS-DZ	44	60	30.4	27.8	42	2600	0.615
85	45	23	22.8	52	64	1.1	0.6		NA2209-2RS	NA2209-2RS-DZ	45	63.9	30.9	29.7	43.7	2400	0.661
90	50	23	22.8	58	70	1.1	0.6		NA2210-2RS	NA2210-2RS-DZ	48	71.36	31	29.4	43.4	2100	0.712

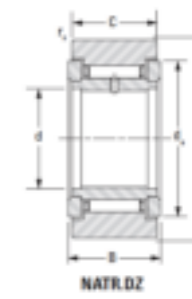
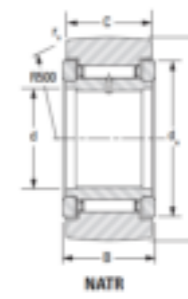
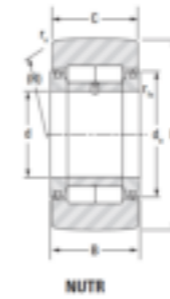
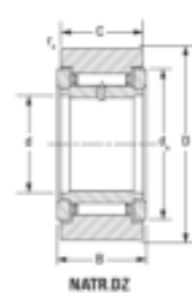
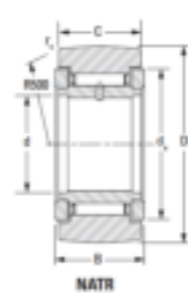

Outer Dia. D	d	B	C	da	rs	r/s min.	Bearing Designation		Load Ratings					Speed Rating Grease	Approx Wt.
							Crowned Track Roller	Cylindrical Track Roller	As a bearing		As a track Roller				
									Cr	COr	Cw	Fr	FOr		
35	15	19	18	24	0.6	0.3	NUTR15	NUTR15DZ	24.7	29.3	16.2	10.1	16.1	6100	0.105
42	15	19	18	24	0.6	0.3	NUTR1542	NUTR1542DZ	22.8	29.4	20	21.2	28.4	6100	0.166
40	17	21	20	27	1.0	0.3	NUTR17	NUTR17DZ	26.6	33.4	18.7	15.0	23.9	5300	0.154
47	17	21	20	27	1.0	0.3	NUTR1747	NUTR1747DZ	24.5	33.3	22.0	28.1	33.6	5300	0.230
47	20	25	24	32	1.0	0.3	NUTR20	NUTR20DZ	39.0	53.2	28.1	20.5	32.7	4500	0.254
52	20	25	24	32	1.0	0.3	NUTR2052	NUTR2052DZ	39.0	53.2	31.6	31.0	45.9	4500	0.326
52	25	25	24	37	1.0	0.3	NUTR25	NUTR25DZ	43.0	63.1	29.6	22.2	35.4	3700	0.291
62	25	25	24	37	1.0	0.3	NUTR2562	NUTR2562DZ	43.0	63.1	36.0	43.9	57.8	3700	0.460
62	30	29	28	44	1.0	0.3	NUTR30	NUTR30DZ	60.0	83.1	40.8	29.0	46.2	3200	0.4800
72	30	29	28	44	1.0	0.3	NUTR3072	NUTR3072DZ	60.0	83.1	48.6	53.2	74.2	3200	0.711
72	35	29	28	50	1.1	0.6	NUTR35	NUTR35DZ	65.5	97.8	45.9	38.7	61.7	2600	0.655
80	35	29	28	50	1.1	0.6	NUTR3580	NUTR3580DZ	65.5	97.8	51.7	58.7	81.9	2600	0.865
80	40	32	30	55	1.1	0.6	NUTR40	NUTR40DZ	88.0	132	60.6	48.0	76.5	2500	0.848
85	45	32	30	60	1.1	0.6	NUTR45	NUTR45DZ	93.0	146	62.0	50.2	80.0	2200	0.917
90	40	32	30	55	1.1	0.6	NUTR4090	NUTR4090DZ	88.0	132	69.1	75.4	111	2500	1.162
90	50	32	30	65	1.1	0.6	NUTR50	NUTR50DZ	98.0	160	63.3	52.9	84.3	2000	0.988
100	45	32	30	60	1.1	0.6	NUTR45100	NUTR45100DZ	93.0	146	74.3	92.2	127	2200	1.412
110	50	32	30	65	1.1	0.6	NUTR50110	NUTR50110DZ	98.0	160	79.0	110	141	2000	1.727

Roller Followers
NATR Series - Metric

Roller Followers
NATR Series - Metric

Outer Dia. D	d	B	C	da	rs min.	Bearing Designation		Load Ratings					Speed Rating Grease	Approx Wt.
						Crowned Track Roller	Cylindrical Track Roller	As a bearing		As a track Roller				
								Cr	COr	Cw	Fr	FOr		
16	5	12	11	13	0.3	NATR5	NATR5DZ	4.62	5.19	3.34	2.62	4.01	13000	0.017
19	6	12	11	16	0.3	NATR6	NATR6DZ	4.84	5.66	3.84	4.28	5.28	12000	0.022
24	8	15	14	20	0.3	NATR8	NATR8DZ	8.39	8.67	6.66	5.79	8.08	10000	0.043
30	10	15	14	24	0.6	NATR10	NATR10DZ	9.57	9.45	8.15	8.58	10.1	9400	0.068
32	12	15	14	26	0.6	NATR12	NATR12DZ	10.2	10.5	8.32	8.5	10.4	8100	0.075

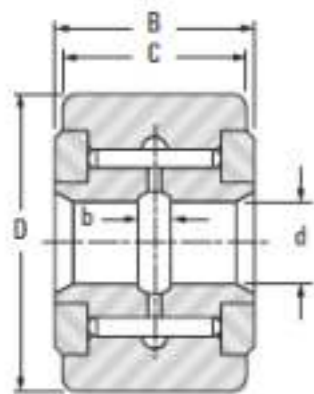

YCR

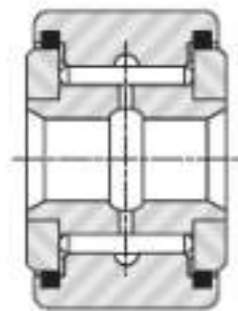

YCRS

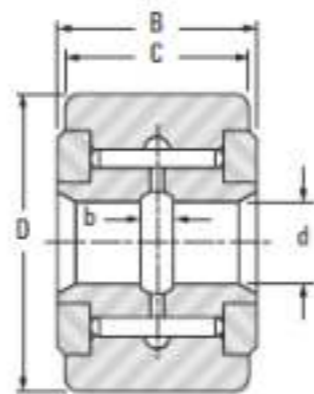
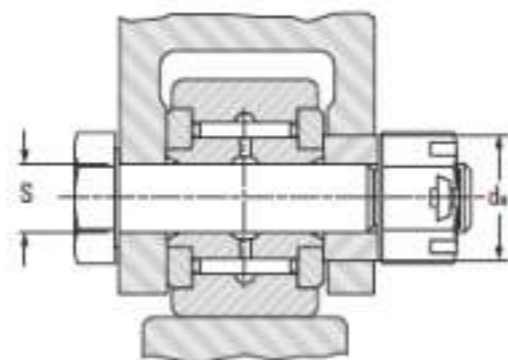

YCR

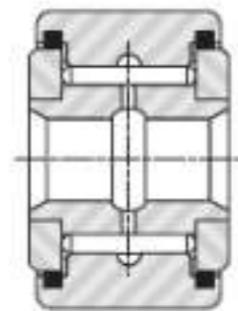

YCRS

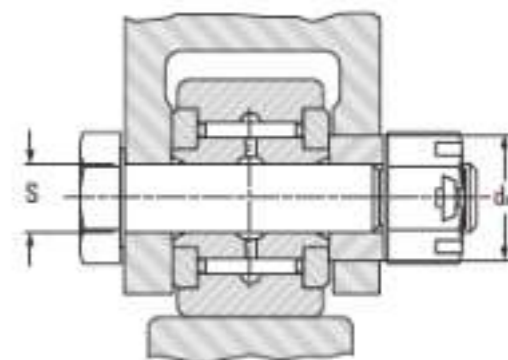

Outer Dia.	D	d		B	C	b	Track Roller Designation		Load Rating			Speed Rating Grease	Mounting Dimensions				da	Approx Wt.			
		Max.	Min.				Without Seals*	With Seals and Internal Thrust Washers	As a Bearing		As a Track Roller			Shaft Bolt Diameters (S)							
in	mm	mm	mm	mm	mm	mm					Cr	COr		Cw	Fr	FOr	min-1	Loose Fit (f7)		Tight Fit	
									kN	kN		kN	kN	kN		mm		mm	mm	mm	N-m
		in	in	in	in	in			lbf	lbf		lbf	lbf	lbf		in	in	in	in	lb-in	lbs
3/4	19.05	6.355	6.34	14.280	12.70	2.95	YCR-12	YCRS-12	10.14	14.68		6.27	2.92	6.98	3800	6.342	6.332	6.363	6.353	1.55	0.03
	0.750	0.2502	0.2496	0.5625	0.500	0.116			2280	3300		1410	656	1570		0.2497	0.2493	0.2505	0.2501	0.61	0.06
7/8	22.23	6.355	6.34	14.280	12.70	2.95	YCR-14	YCRS-14	10.14	14.68		7.38	4.94	11.88	3800	6.342	6.332	6.363	6.353	1.55	0.04
	0.875	0.2502	0.2496	0.5625	0.500	0.116			2280	3300		1660	1110	2670		0.2497	0.2493	0.2505	0.2501	0.610	0.08
1	25.40	7.943	7.927	17.460	15.88	3.18	YCR-16	YCRS-16	12.99	21.93		8.41	5.60	13.43	2800	7.930	7.920	7.950	7.940	1.98	0.07
	1.000	0.3127	0.3121	0.6875	0.625	0.125			2920	4930		1890	1260	3020		0.3122	0.3118	0.3130	0.3126	0.780	0.15
1 1/8	28.58	7.943	7.927	17.460	15.88	3.18	YCR-18	YCRS-18	12.99	21.93		9.43	8.18	17.48	2800	7.930	7.920	7.950	7.940	1.98	0.08
	1.125	0.3127	0.3121	0.6875	0.625	0.125			2920	4930		2120	1840	3930		0.3122	0.3118	0.3130	0.3126	0.780	0.17
1 1/4	31.75	9.53	9.515	20.640	19.05	3.20	YCR-20	YCRS-20	23.31	30.29		16.06	7.38	17.75	2700	9.517	9.507	9.538	9.528	2.49	0.11
	1.250	0.3752	0.3746	0.8125	0.750	0.126			5240	6810		3610	1660	3990		0.3747	0.3743	0.3755	0.3751	0.980	0.24
1 3/8	34.93	9.53	9.515	20.640	19.05	3.20	YCE-22	YCRS-22	23.31	30.29		17.66	10.45	25.04	2700	9.517	9.507	9.538	9.528	2.49	0.14
	1.375	0.3752	0.3746	0.8125	0.750	0.126			5240	6810		3970	2350	5630		0.3747	0.3743	0.3755	0.3751	0.980	0.3
1 1/2	38.10	1.118	11.102	23.810	22.23	3.18	YCR-24	YCRS-24	28.16	40.26		20.15	11.97	28.74	2700	11.105	11.095	11.125	11.115	2.77	0.19
	1.500	0.4377	0.4371	0.9375	0.875	0.125			6330	9050		4530	2690	6460		0.4372	0.4368	0.4380	0.4376	1.090	0.41
1 5/8	41.20	1.118	11.102	23.810	22.23	3.18	YCR-26	YCRS-26	28.16	40.26		21.62	15.66	36.08	2300	11.105	11.095	11.125	11.115	2.77	0.23
	1.625	0.4377	0.4371	0.9375	0.875	0.125			6330	9050		4860	3520	8110		0.4372	0.4368	0.4380	0.4376	1.090	0.5
1 3/4	44.45	12.703	12.687	26.990	25.40	3.20	YCR-28	YCRS-28	35.50	56.49		25.93	19.04	45.82	1900	12.692	12.682	12.718	12.708	3.18	0.29
	1.750	0.5001	0.4995	1.0625	1.000	0.126			7980	12700		5830	5280	10300		0.4997	0.4993	0.5007	0.5003	1.250	0.64
1 7/8	47.63	12.703	12.687	26.990	25.40	3.20	YCR-30	YCRS-30	35.50	56.49		27.40	23.66	51.15	1900	12.692	12.682	12.718	12.708	3.18	0.36
	1.875	0.5001	0.4995	1.0625	1.000	0.126			7980	12700		6160	5320	11500		0.4997	0.4993	0.5007	0.5003	1.250	0.8
2	50.80	15.878	15.862	33.340	31.75	3.20	YCR-32	YCRS-32	43.19	75.62		31.89	28.11	62.72	1700	15.867	15.857	15.893	15.883	3.58	0.48
	2.000	0.6251	0.6245	1.3125	1.250	0.126			9710	17000		7170	6320	14100		0.6247	0.6243	0.6257	0.6253	1.410	1.05
2 1/4	57.15	15.878	15.862	33.340	31.75	3.20	YCR-36	YCRS-36	43.19	75.62		34.70	39.86	73.40	1700	15.867	15.857	15.839	15.883	3.58	0.60
	2.250	0.6251	0.6245	1.3125	1.250	0.126			9710	17000		7800	8960	16500		0.6247	0.6243	0.6257	0.6253	1.410	1.32
2 1/2	63.50	19.053	19.037	39.690	38.10	3.68	YCR-40	YCRS-40	58.27	117.43		44.48	54.71	104.09	1400	19.042	19.032	19.068	19.058	4.29	0.82
	2.500	0.7501	0.7495	1.5625	1.500	0.145			13100	26400		10000	12300	23400		0.7497	0.7493	0.7507	0.7503	1.690	1.8
2 3/4	69.85	19.053	19.037	39.690	38.10	3.68	YCR-44	YCRS-44	58.27	117.43		47.15	71.17	116.54	1400	19.042	19.032	19.068	19.058	4.29	1.02
	2.750	0.7501	0.7495	1.5625	1.500	0.145			13100	26400		10600	16000	26200		0.7497	0.7493	0.7507	0.7503	1.690	2.25
3	76.20	25.403	25.387	46.040	44.45	3.68	YCR-48	YCRS-48	74.29	177.93		51.60	68.50	131.22	990	25.390	25.377	25.420	25.408	5.41	1.41
	3.000	1.0001	0.9995	1.8125	1.750	0.145			16700	40000		11600	15400	29500		0.9996	0.9991	1.0008	1.0003	2.130	3.1
3 1/4	82.55	25.403	25.387	46.040	44.45	3.68	YCR-52	YCRS-52	74.29	177.93		54.71	85.85	147.24	990	25.390	25.377	25.420	25.408	5.41	1.64
	3.250	1.0001	0.9995	1.8125	1.750	0.145			16700	40000		12300	19300	33100		0.9996	0.9991	1.0008	1.0003	2.130	3.62

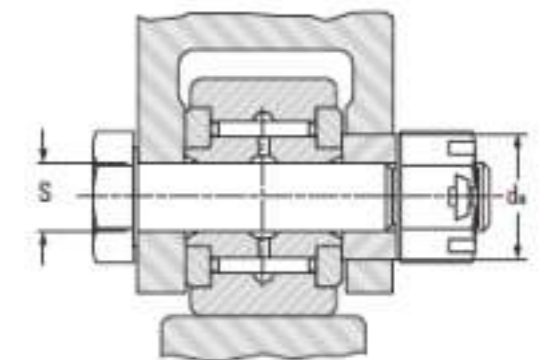
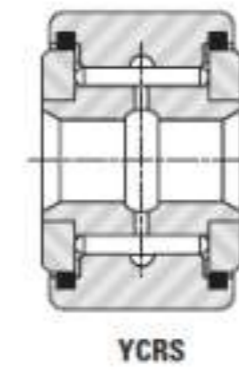
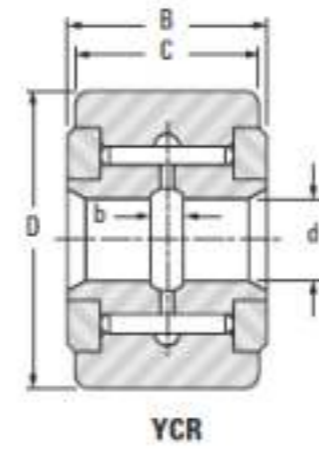
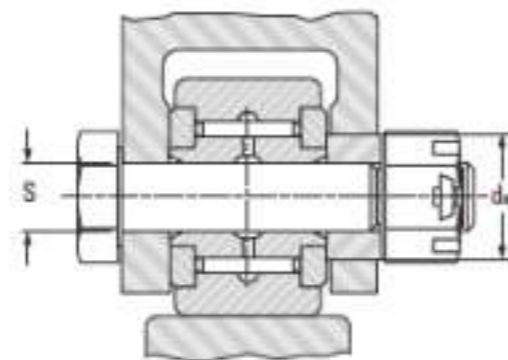
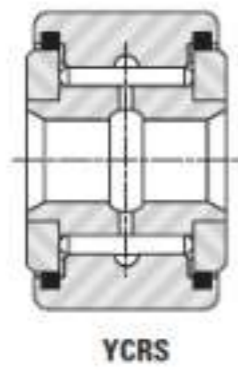
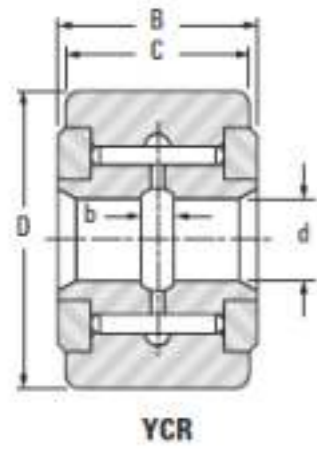

Outer Dia.	D	d		B	C	b	Track Roller Designation		Load Rating			Speed Rating Grease	Mounting Dimensions				da	Approx Wt.		
		Max.	Min.				Without Seals*	With Seals and Internal Thrust Washers	As a Bearing		As a Track Roller			Shaft Bolt Diameters (S)						
		Cr	COr						Cw	Fr	FOr		Loose Fit (f7)		Tight Fit				Clamping Diameter Min	
		kN	kN										Max.	Min.	Max	Min				N-m
3 1/2	88.90	28.578	28.562	52.390	50.80	3.68	YCR-56	YCRS-56	109.87	225.52	950	28.565	28.552	28.595	28.583	6.20	2.25			
	3.500	1.1251	1.1245	2.0625	2.000	0.145			24700	50700		18500	21300	43000	1.1246	1.1241	1.1258	1.1253	2.440	4.95
4	101.60	37.753	37.737	58.740	57.15	3.68	YCR-64	YCRS-64	137.89	319.38	780	31.740	31.727	31.770	31.758	7.11	3.20			
		4.000	1.2501	1.2495	2.3125	2.250			0.145	31000		71800	22200	28300	56300	1.2496	1.2491	1.2508	1.2503	2.800
5	127.00	44.453	44.437	73.030	69.85	8.66	YCR-80	YCRS-80	210.40	484.86	620	44.440	44.427	44.470	44.458	9.04	6.51			
		5.000	1.7501	1.7495	2.875	2.750			0.341	47300		109000	33500	38600	83200	1.7496	1.7491	1.7508	1.7503	3.560

Automotive Angular Contact Bearings

Bearing No.	Boundary dimensions(mm)					Automotive Position
	d	D	B	C	T	
DAC286142AWCS40MNPO/00R	28	61	42	-	-	Angular Contact Automotive - Wheel
DAC3055W-3CS31FGPO/00RQ	30	55	32	-	-	Angular Contact Automotive - Wheel
DAC3063W-1CS44MNPO/00RQ	30	63.03	42	-	-	Angular Contact Automotive - Wheel
DAC3464W-52RSCS44	34	64	-	-	37	Angular Contact Automotive - Wheel
DAC3464W-52RSCS44MNPO/0	34	64	37	-	-	Angular Contact Automotive - Wheel
DAC3564A-1CS31MNPO/00RQ	35	64	37	-	-	Angular Contact Automotive - Wheel
DAC3568W-6CS81MNPO/00RQ	34.99	68.02	33	-	-	Angular Contact Automotive - Wheel
DAC357233B-1WCS79MNPO/0	35	72	33	31	-	Angular Contact Automotive - Wheel
DAC3577W-3CS80MNPO/00RQ	34.99	77.04	42	-	-	Angular Contact Automotive - Wheel
DAC3580WHR4CS0FGPO/00RQ	35	80	47	-	-	Angular Contact Automotive - Wheel
DAC3871W-2CS70MNPO/00RQ	37.99	71.02	33	-	-	Angular Contact Automotive - Wheel
DAC3871W-3CS63FGPO/00RQ	38	71	39	-	-	Angular Contact Automotive - Wheel
DAC3873W-2CS71MNPO/00UQ	38	73	40	-	-	Angular Contact Automotive - Wheel
DAC3874W-6CS84MNPO/00RQ	37.988	74.02	36	-	-	Angular Contact Automotive - Wheel
DAC3880W-1CS65FG00/00RQ	38	80	36	-	-	Angular Contact Automotive - Wheel
DAC4072W-15CS74FGPO/00R	39.99	72.08	36	-	-	Angular Contact Automotive - Wheel
DAC4072W-3CS35FGPO/00RQ	40	72	36	-	-	Angular Contact Automotive - Wheel
DAC4074CWC573FGPZ/00RQA	40	74	36	-	-	Angular Contact Automotive - Wheel
DAC4074W-12CS47FGPO/00R	40	74	40	-	-	Angular Contact Automotive - Wheel
DAC4074W-3CS80FGPO/00RQ	40	74	42	-	-	Angular Contact Automotive - Wheel
DAC4076412RSCS4MNPZ/00A	40	76	41	-	-	Angular Contact Automotive - Wheel
DAC4080M1CS68MGPZ/00A2A	40	80	36	-	-	Angular Contact Automotive - Wheel
DAC4168WHR4CS23FGPO/00R	41	68	40	-	-	Angular Contact Automotive - Wheel
DAC4275W-4CS79FGPO/00E9	42	75	37	-	-	Angular Contact Automotive - Wheel
DAC4278C2RSCS40FGPZ/00R	42	78	41	-	-	Angular Contact Automotive - Wheel
DAC4278W-3HR4CS52FGPZ/0	42	78	45	-	-	Angular Contact Automotive - Wheel
DAC4280W-13CS40FGPZ/00R	42	80	45	-	-	Angular Contact Automotive - Wheel
DAC4280W-14CS40FGPZ/00R	42	80	45	-	-	Angular Contact Automotive - Wheel
DAC4280WAHR4CS9FGPZ/00R	42	80	45	-	-	Angular Contact Automotive - Wheel
DAC4379W-1CS57FGPZ/00UQ	43	79	41	-	-	Angular Contact Automotive - Wheel
DAC4380ACS69MNPO/00RQA	43	80	50	-	-	Angular Contact Automotive - Wheel
DAC4382W-3CS79FGPO/00RQ	43	82	45	-	-	Angular Contact Automotive - Wheel
DAC4584DWCS76FGPO/00RQA	45	84	41	-	-	Angular Contact Automotive - Wheel
DAC4584W-1CS81FGPO/00RQ	45	84	45	-	-	Angular Contact Automotive - Wheel
DAC4889W-1CS16FGPZ/00RQ	48	89	44	-	-	Angular Contact Automotive - Wheel
DAC2552W-13CS25FGPO/00R	25	52	42	-	-	Double Row Angular Contact Automotive - Wheel

d = Inside Diameter mm C = Cup Width mm
 D = Outside Diameter mm T = Overall Width mm
 B = Cone Width mm

Every effort has been taken to ensure that the data listed in this catalogue is correct. Finer Power Transmissions P/L will not accept liability for any damage or loss caused as a result of the data in this catalogue.

Automotive Taper Roller Bearings

Bearing No.	Boundary dimensions(mm)					Automotive Position
	d	D	B	C	T	
HC46T080604-1LFTCZ/PZA	38	64	36	-	-	Automotive - Wheel Bearing
HC46T090804ALFT/PZ/00A	43	77	21	38	42	Automotive - Wheel Bearing
HI-CAP46T080704XMGpz/00	42	72	35	38	-	Automotive - Wheel Bearing
HI-CAP46T080705CCZMGpzA	38	65	52	48	-	Automotive - Wheel Bearing
HI-CAPLM501349LFTZ/PZB	41.275	72	19.812	14.73	19.558	Tapered Roller - Imp. Auto - Gearbox
HC57410LFT/LM2971Z/Z2A	38.1	65.088	21.139	13.97	18.034	Tapered Roller - Imp. Auto - Wheel
HI-CAP57414/LM300Z/A4A	40.987	67.975	18	13.5	17.5	Tapered Roller - Imp. Auto - Wheel
HI-CAP57207/LM297Z/A4A	38.1	65.088	18.288	13.97	18.03	Tapered Roller - Imp. Automotive
HI-CAP30304AJR-2/P0N00	20	52	16	13	16.25	Tapered Roller - Metric
HI-CAP30307JR-4/P0/00	35	80	21	18	22.75	Tapered Roller - Metric
KE32310JR-2LFTUR4/P0/0	50	110	40	33	42.25	Tapered Roller - Metric
TR131305R	65	130	48	39	51	Tapered Roller - Metric Automotive
ST4090/P0N00 A	40	90	29	22	30	Tapered Roller - Metric Automotive - Differential
ST4096LFT/P0/00 A	40	96	38	-	-	Tapered Roller - Metric Automotive - Differential
HC57160LFT/PZ/00 A	45	85	19	16	20.75	Tapered Roller - Metric Automotive - Gearbox
HCST4580LFT/PZ/00 A	45.23	80	20.638	15.08	19.84	Tapered Roller - Metric Automotive - Gearbox
HCST4890/P0/00 A	48	90	23	18	23	Tapered Roller - Metric Automotive - Gearbox
HCTR080702J/P0/00 A	38.5	68	16.5	15	18.5	Tapered Roller - Metric Automotive - Gearbox
STA6095/P0/00 A	60	95	21.5	17	23	Tapered Roller - Metric Automotive - Gearbox
TR0607J-1LFT	30	72	23	16.5	24	Tapered Roller - Metric Automotive - Gearbox
TR0608	32	75	-	-	29.75	Tapered Roller - Metric Automotive - Gearbox
TR070902/PZ/00 A	35	85.001	21	17.463	20.638	Tapered Roller - Metric Automotive - Gearbox
TR070904	89	-	-	-	-	Tapered Roller - Metric Automotive - Gearbox
TR0807-1R	35	80	31	25	32.75	Tapered Roller - Metric Automotive - Gearbox
TR080803	40	80	-	-	31	Tapered Roller - Metric Automotive - Gearbox
TR0809-A	40	90	-	-	33	Tapered Roller - Metric Automotive - Gearbox
TR100802	50	83	-	-	-	Tapered Roller - Metric Automotive - Gearbox
HCSTA3072-1LFT/P0/00 A	30	72	23	16.5	24	Tapered Roller - Metric Automotive - Pinion
KESTA3053/P0/00 A	30	53	16	13	16	Tapered Roller - Metric Automotive - Pinion
HI-CAPTR0305C-9/P0/00	17	47	15	11	15.25	Tapered Roller - Metric Automotive - Steering
57326/P0/00 A	60	95	23	17.5	23	Tapered Roller - Metric Automotive - Wheel
57402JR/P0/00 A	45	100	25	22	27.25	Tapered Roller - Metric Automotive - Wheel
HCSTA3574LFT/P0/00 A	35	74	26	19	26	Tapered Roller - Metric Automotive - Wheel
HCSTA5076LFT/P0/00 A	50	76	18.4	16	20	Tapered Roller - Metric Automotive - Wheel
HI-CAP57305/30207J/P0/	35	72	17	15	18.25	Tapered Roller - Metric Automotive - Wheel

d = Inside Diameter mm C = Cup Width mm
 D = Outside Diameter mm T = Overall Width mm
 B = Cone Width mm

Automotive Taper Roller Bearings

Bearing No.	Boundary dimensions(mm)					Automotive Position
	d	D	B	C	T	
HI-CAP57396R/3220Z//POA	45	85	23	19	24.75	Tapered Roller - Metric Automotive - Wheel
HI-CAP57407/32008J//PO/	40	68	19	14.5	19	Tapered Roller - Metric Automotive - Wheel
HI-CAPST2857LFTSH3//PON	28	57	17	13	17	Tapered Roller - Metric Automotive - Wheel
HI-CAPST3368-1//PON00 A	33	68	19	14.5	19	Tapered Roller - Metric Automotive - Wheel
HI-CAPST4080C//PO/00 A	40	80	34	27	34	Tapered Roller - Metric Automotive - Wheel
KEST3962LFT//PO/00 A	38.5	62	13.5	10.5	13.5	Tapered Roller - Metric Automotive - Wheel
HI-CAP30304AJRRS//PO/00	20	52	16	13	16.25	Tapered Roller - Metric Sealed

Automotive Ball Bearings

Bearing No.	Boundary dimensions(mm)					Automotive Position
	d	D	B	C	T	
DG4380CS58//PO/00A2A	43	80	17	-	-	Ball Bearing Automotive - Differential
6207YR6C3//PO/00 A	35	72	17	-	-	Ball Bearing Automotive - Gearbox
83A898C4//PZ/00	35.25	80	21	-	-	Ball Bearing Automotive - Gearbox
83A915SH2-9TC4//PO/00 A	25	55	15	-	-	Ball Bearing Automotive - Gearbox
DG3580AC4//PO/00 A	35.2	80	21	-	-	Ball Bearing Automotive - Gearbox
DG35852RKMDSH2C3//PO/O	35	85	23	-	-	Ball Bearing Automotive - Gearbox
DG2263-12RKMDSH2C4//PO/	22	63	18	-	-	Ball Bearing Automotive - Tensioner
DG2455302RDFG5B/00	24	55	30	-	-	Ball Bearing Automotive - Tensioner
DG256318CS12//PO/00 A	25	63	18	-	-	Ball Bearing Automotive - Tensioner
DG2568HNSH2C3MGPO/00 A	25	68	19	-	-	Ball Bearing Automotive - Tensioner
6308W-12RSHR4C5//PO/00A	40	90	28	-	-	Ball Bearing Automotive - Wheel
DAC164044-2RSLCS16	16.256	40	44.12	39.12	-	Ball Bearing Automotive - Wheel
DG357226W2R5C4//PZ/00A2	35	72	26	17	-	Ball Bearing Automotive - Wheel
DG358021WYAC4//PO/00 A	35	80	21	-	-	Ball Bearing Automotive - Wheel
DG358026WRKBC4//PO/00A2	35	80	26	-	-	Ball Bearing Automotive - Wheel
DG4080WRKBSH2C4//PO/00A	40	80	23	18	-	Ball Bearing Automotive - Wheel
DG4092A2RKBDSRHRZ//POA	40	92	25.5	-	-	Ball Bearing Automotive - Wheel
DG4094W-12RSHR4SHZ//POA	40	94	31	26	-	Ball Bearing Automotive - Wheel
DG4180CS58//PO/00A2A	41	80	17	-	-	Ball Bearing Automotive - Wheel
6210R2RKMDC3//PO/00SRA	50	90	20	-	-	Stainless Steel Ball Bearing Automotive

d = Inside Diameter mm C = Cup Width mm
 D = Outside Diameter mm T = Overall Width mm
 B = Cone Width mm

Automotive Clutch Release Bearings

Bearing No.	Boundary dimensions(mm)					Automotive Position
	d	D	B	C	T	
CBU553623FGP0/08UNA	36	68.6	-	58	33.5	Clutch Release
RCT4000SAFGP0/08UNA	40	81.4	-	62	19	Clutch Release
RCT405AMNP0/08UNA	40	81.4	-	62	22.9	Clutch Release



Automotive Cylindrical Roller Bearings – Gearbox

Bearing No.	Boundary dimensions(mm)					Automotive Position
	d	D	B	C	T	
RNU080821NR/PZ/02 A	40	75	21	-	-	Cylindrical Roller Automotive - Gearbox
06NUP0618/P0/00 A	30	62	18	-	-	Cylindrical Roller Automotive - Gear Box
06NUP0820ANRS02C3/PZ/0	32	75	20	-	-	Cylindrical Roller Automotive - Gear Box

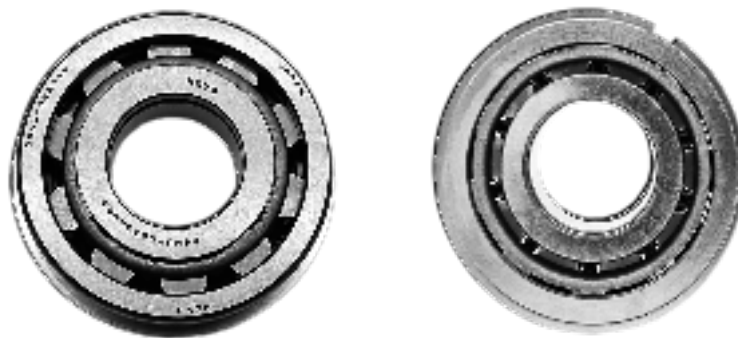

d = Inside Diameter mm C = Cup Width mm
 D = Outside Diameter mm T = Overall Width mm
 B = Cone Width mm

Automotive Needle Roller Bearings

Bearing No.	Boundary dimensions(mm)			Automotive Position
	d	D	B	
40VPU4943B/P0/03 A	40	49	43	Needle Roller - Automotive
RP193124A/P0/03 A	19	31	24	Needle Roller & Cage Assembly - Automotive
RP384433/P0/03 A	38	44	33	Needle Roller & Cage Assembly - Automotive
RP384436WRP0/03 A	38	44	36	Needle Roller & Cage Assembly - Automotive
RP445039/P0/03 A	44	50	39	Needle Roller & Cage Assembly - Automotive
RP475336WRP0/03 A	47	53	36	Needle Roller & Cage Assembly - Automotive
RPU303828AF/P0/03 A	30	38	28.3	Needle Roller & Cage Assembly - Automotive
RVU323942/P0/03 A	32	39	42	Needle Roller & Cage Assembly - Automotive
BSM354126AJ/P0/02 A	35	40.5	26	Needle Roller Automotive - Gearbox
BT1112-1WRP0/02 A	17.46	21.88	18.75	Needle Roller Automotive - Gearbox
BTM3516/P0/02 A	35	42	16	Needle Roller Automotive - Gearbox
WRP394644AWRP0/03 A	39	46	44.3	Needle Roller Automotive - Gearbox
34VP4440-1/P0/03 A	34	44	40	Needler Rolle & Cage Assembly - Automotive
38VP5243/P0/03 A	38	52	43	Needler Rolle & Cage Assembly - Automotive
25VI4625/P0/01 A	25	46	25	Needle Roller - Automotive - Clutch
25VP3332-1/P0/03 A	25	32.81	31.25	Needle Roller - Automotive - Gearbox
19VP2821A-1/P0/03 A	18.63	27.63	21	Needle Roller & Cage Assembly - Automotive
32VU3828-2/P0/03 A	32	38	23	Needler Rolle & Cage Assembly - Automotive



d = Inside Diameter mm
 D = Outside Diameter mm
 B = Width mm

Automotive Tensioner Pulleys

Bearing No.	Boundary dimensions(mm)					Automotive Position
	d	D	B	d1	d2	
DG2852B82RR1H+SV1MGP0/0	26	52	19	-	-	Tensioner Pulley - Automotive
DG60932RD1HCS64+SZ/P0A	60	93	40	-	-	Tensioner Pulley - Automotive
LAT1035-AMFGP0/08K7A	-	62	28.5	-	-	Tensioner Pulley - Automotive
PU006036RDYFGSB/00	-	-	-	-	-	Tensioner Pulley - Automotive
PU006038RR9DYFGP0/08K7A	17	70	33	-	-	Tensioner Pulley - Automotive
PU101226RMXWFGP0/08K8A	10.3	120	30.2	-	-	Tensioner Pulley - Automotive
PU105529RMXY5FGP0/08K8A	10.3	59	29.2	-	-	Tensioner Pulley - Automotive
PU106018FRR1DFGP0/00K7A	10.2	60	35	-	-	Tensioner Pulley - Automotive
PU106018JRR1DWFGP0/08K7	10.2	66	32.6	-	-	Tensioner Pulley - Automotive
PU107013ARMXY1FGP0/08K8	10.3	70	32	-	-	Tensioner Pulley - Automotive
PU107029RMXYFGP0/08K8A	10.3	70	33	-	-	Tensioner Pulley - Automotive
PU126231ARR9DFGP0/00K7A	12	62	36.6	-	-	Tensioner Pulley - Automotive
PU128424RR9DWFGP0/08K7A	12	83.523	35	-	-	Tensioner Pulley - Automotive
PU158026ARR1HYFGP0/08K8	10.2	80	28.5	-	-	Tensioner Pulley - Automotive
PU159026RR1HYFGP0/08K8A	10.2	98	27.5	-	-	Tensioner Pulley - Automotive
PU255424ARR1DFGP0/00K7N	10	60	29.5	-	-	Tensioner Pulley - Automotive
PU255728CRR1HV1FGP0/00K	25	57	25	-	-	Tensioner Pulley - Automotive
PU276033CRR1DFGP0/00K7A	10.2	60	24	-	-	Tensioner Pulley - Automotive
PU276033RR1DFGP0/00K7A	10.2	60	32	-	-	Tensioner Pulley - Automotive
PU277027HRR1ZS1/P0/00K	27	70	19	-	-	Tensioner Pulley - Automotive
PU285226BRR1HV1MGP0/00E	28	52	25	-	-	Tensioner Pulley - Automotive
PU285524ARR1DFGP0/00K8A	19.2	55	30	-	-	Tensioner Pulley - Automotive
PU285739RR1DVFGP0/00K7A	28	56.6	26	-	-	Tensioner Pulley - Automotive
PU305217RR9DW-AMFGP0/08	-	-	-	-	-	Tensioner Pulley - Automotive
PU305729ARR1DW1FGP0/08K	10.2	63.4	38.7	-	-	Tensioner Pulley - Automotive
PU305733DRR1DY6FGP0/08K	30	63.4	32.1	-	-	Tensioner Pulley - Automotive
PU306030FRR9HFGP0/00K7A	10.4	60	35	-	-	Tensioner Pulley - Automotive
PU315521RR1DFGP0/00K8A	19.2	55	24	-	-	Tensioner Pulley - Automotive
PU326231GRR1DVFGP0/00K8	30	62	27	-	-	Tensioner Pulley - Automotive
PU355816RR9DFGP0/00K7N	12	57.6	29	-	-	Tensioner Pulley - Automotive
PU385827ARR9DYFGP0/08K7	30	57.6	29	-	-	Tensioner Pulley - Automotive
PU406222RR9DY1FGP0/08K7	-	62	43.4	-	-	Tensioner Pulley - Automotive
U00135RFGP0/08K7A	-	60.6	30.5	-	-	Tensioner Pulley - Automotive

d = Smaller End of Inside Diameter mm d1 = Larger End of Inside Diameter mm
 D = Outside Diameter mm d2 = Center Diameter mm
 B = Width mm

Automotive Hub Units

Bearing No.	Automotive Position
3DACF026F-16S-AMFGP0/00	Hub Unit - Automotive
3DACF026F-23-AMFGP0/00R	Hub Unit - Automotive
3DACF026F-7A-AMFGP0/00R	Hub Unit - Automotive
3DACF027F-28CS-AMFGP0/0	Hub Unit - Automotive
3DACF027F-48DS-AMFGP0/0	Hub Unit - Automotive
3DACF031F-10AR-AMFGP0/0	Hub Unit - Automotive
3DACF033F-7ES-AMFGP0/00	Hub Unit - Automotive
3DACF037D-16AR-AMFGP0/0	Hub Unit - Automotive
3DACF037D-2C-AMFGP0/00R	Hub Unit - Automotive
3DACF038D-15BR-AMFGP0/0	Hub Unit - Automotive
3DACF038D-37BR-AMFGP0/0	Hub Unit - Automotive
3DACF041D-6DR-AMFGP0/00	Hub Unit - Automotive
3DACF044D-10BR-AMFGP0/0	Hub Unit - Automotive
3DACF044D-21DR-AMFGP0/0	Hub Unit - Automotive
3DACF044DC-AMFGP0/00RQA	Hub Unit - Automotive
3DACF045F-4R-AMFGP0/00R	Hub Unit - Automotive
3DACF046D-10RFGP0/00RQA	Hub Unit - Automotive
3DUF050D-18R-AMFGP0/00R	Hub Unit - Automotive
DACF1041HFGP0/00RQA	Hub Unit - Automotive
2DACF037GRFGP0/00RQA	Hub Unit - Automotive
2DACF044N-4FGP0/00RQA	Hub Unit - Automotive
2DACF049N-6DRFGPZ/00RQA	Hub Unit - Automotive

Bearing No.	Automotive Position
2DACF049N-6ERFGPZ/00RQA	Hub Unit - Automotive
2DACF049N-7BRFGPZ/00RQA	Hub Unit - Automotive
2DACF049N-7CRFGPZ/00RQA	Hub Unit - Automotive
2DACF049N-9ARFGPZ/00	Hub Unit - Automotive
2DACF049N-9RFGPZ/00	Hub Unit - Automotive
2DUF054N-2GRMGFZ/00RQA	Hub Unit - Automotive
2DUF054N-6MGFZ/00RQA	Hub Unit - Automotive
2DUF054N-9-AMMGFZ/00RQA	Hub Unit - Automotive
2DUF058N-5BRMGFZ/00RQA	Hub Unit - Automotive



Tapered Roller Bearings

BEARING #	SET	BEARING #	SET	BEARING #	SET
LM11749/10	SET1 / SET D	HM88649/10	SET67	LM300849/11	SET318
LM11949/10	SET2 / SET A	LM501349/14	SET69	M802048/10	SET328
M12649/10	SET3	LM29749/10	SET70	02474/20	SET362
L44649/10	SET4 / SET C	15101/245	SET73	395/394A	SET365
LM48548/10	SET5	387/382A	SET75	580/572	SET401
LM67048/10	SET6 / SET B	387A5/382A	SET76	582/572	SET402
L45449/10	SET8	55200C/55437	SET78	594A/592A	SET403
U399	SET10	HM88542/10	SET81	598A/592A	SET404
JL69349/10	SET11	LM104949/10	SET82	663/653	SET405
LM12749/10	SET12 / SET E	25877A/25821	SET96	3782/3720	SET406
L68149/10	SET13 / SET F	HM212049/10	SET99	286682/22	SET407
L44643/10	SET14	HM89446/10	SET100	39590/39520	SET408
07100/07196	SET15	3982/3920	SET103	45280/20	SET409
LM12749/11	SET16	L44642/10	SET104	45284/20	SET410
L68149/11	SET17	JLM104948/10	SET107	47686/47620	SET411
LM102949/11	SET18	JLM506849/10	SET118	HM212047/11	SET412
U399A	SET20	25580/22	SET122	HM212049/11	SET413
1988/1922	SET21	3780/20	SET123	HM218248/10	SET414
LM67048/10BCE	SET27	368A/362A	SET201	HM518445/10	SET415
LM603049/12	SET36	469/453X	SET205	45291/20	SET416
LM603049/11	SET37	M88046/10	SET219	47890/47820	SET417
LM104949/11	SET38	HM88649/10	SET222	H715334/11	SET418
15123/15245	SET43	2788/20	SET230	H715343/11	SET419
LM501349/10	SET45	M88043/10	SET242	H715345/11	SET420
LM102949/10	SET47	18590/20	SET253	HM516449A/10	SET421
25580/20	SET52	LM29749/11	SET268	HM516449C/10	SET422
LM29748/10	SET56	U298	SET280	6461A/20	SET423
11590/20	SET61	U298H	SET284	5555/552A	SET424
M88048/10	SET63	M84548/10	SET308	567/563	SET425
HM903249/10	SET64	M86649/10	SET309	47679/10	SET426
HM86647/10	SET65	HM89449/10	SET312		

Needle Roller Bearings

IKO	KOYO/TOR	INA	FAG	SKF	MCGILL	Description
AS	AS	AS	AS	AS	-	NR - Thrust Washer
AZK		K	K	K	-	CR - Thrust Cage & Roller
BA	J	SCE	-	-	-	NR - Shell Type w/Oil Hole
BHA	JH	SCH	-	-	-	NR HD - Shell Type w/Oil Hole
BR	HJ	NCS	-	-	MR	NR - w/o Inner Ring
CF...	-	KR...X	KR...DZ	KR...X	MCFR...X	-
CF...B	-	KR...XSK	-	KR...XSK	MCFR...BX	CF - Hex Sealed cyl. Outer Ring
CF...BR	-	KR...SK	-	KR...SK	MCFR...B	CF - Hex Sealed Crowned Outer Ring
CF...FB	-	-	-	-	-	CF- Stainless Steel Hex Sealed Cyl. Outer ring
CF...FBR	-	-	-	-	-	CF- Stainless Steel Hex Sealed Crowned Outer ring
CF...R	-	KR	KR	KR	MCFR	-
CF...V	-	KRV...X	-	KRV...X	MCF...X	-
CF...VB	-	KRV...XSK	-	KRV...XSK	MCF...BX	CF - Full Comp Hex Sealed, cyl. Outer Ring
CF...VBR	-	KRV...SK	-	KRV...SK	MCF...B	CF - Full Comp Hex Sealed, Crowned. Outer Ring
CF...VR	-	KRV	-	KRV	MCF	-
CFE	-	KRE...X	-	-	-	-
CFE...B	-	KRE...XSK	-	-	-	CF - Eccentric Collar, Hex, Sealed Cyl. Outer Ring
CFE...BR	-	KRE...SK	-	-	-	CF - Eccentric Collar, Hex, Sealed Crowned. Outer Ring
CFE...R	-	KRE	-	-	-	-
CFE...V	-	KRVE...X	-	-	-	-
CFE...VB	-	KRVE...XSK	-	-	-	CF - Eccentric Collar, Hex, Sealed Cyl. Outer Ring
CFE...VBR	-	KRVE...SK	-	-	-	CF - Eccentric Collar, Full comp, Hex, Sealed Crowned. Outer Ring
CFE...VR	-	KRVE	-	-	-	-
CR...	-	CFC	-	-	-	-
CR...B	-	CFC...SK	-	-	-	CF- Hex Sealed, cyl. Outer Ring
CR...BR	-	CFC...YSK	-	-	-	CF- Hex Sealed, Crowned Outer Ring
CR...R	-	CFC...Y	-	-	-	-
CR...V	CR	CF	-	-	CF	CF- Full Comp Slotted, Sealed Cyl. Outer Ring
CR...VB	CRB	CF...SK	-	-	CF...B	CF - Full Comp, HEX, sealed Cyl. Outer ring
CR...VBR	CRBC	CF...YSK	-	-	CCF...B	CF - Full comp, HEX, sealed Crowned Outer ring
CR...VR	CRC	CF...Y	-	-	CCF	-
CRH...VB	-	-	-	-	CFH...B	CF - Full Comp, HD hex Sealed, cyl Outer Ring
CRH...VBR	-	-	-	-	CCFH...B	CF - Full Comp, HD hex Sealed, Crowned Outer Ring
CRY...V	-	-	-	-	CYR	RF - Non Sep, Full Comp, Sealed cyl. Outer Ring
CRY...VR	-	-	-	-	CCYR	RF - Non Sep, Full Comp, Sealed Crowned. Outer Ring
GBR	-	-	-	-	GR	-
GS	GS	GS	GS	GS	-	NR - Thrust, Outer ring/Housing Washer
IRB	IR	SI	-	-	-	NR - Shell Type - Inner Ring
IRT	JR	IR	JR	IR	-	NR - Shell Type - Inner Ring
KT	FWJV	K	K	K	-	NR - Cage
KT...EG		KZK	K...FV	KZK	-	-
KTV...EG		KBK	K...FKIV	KBK	-	-
LRB	IR	PI	-	-	MI	NR - Machined, Inner Ring
LRBZ	IR	-	-	-	MI	-
LRT	JR	IR	JR	IR	-	NR - Machined - Inner Ring
LRTZ	JRZ	IR	JRZ	IRZ	-	NR - Machined - Inner Ring
NA	NA	NA	NA	NA	-	NR - Machined - Inner Ring
NAF	-	NAO	NAO	NAO	-	-
NART...R	NATR	NATR	NATR	NATR	MCYRR	RF - Non - Sep, sealed, Crowned Outer Ring
NART...VR	-	NATV	-	NATV	MCYR	RF - Non Sep, Full Comp, Sealed Crowned outer Ring
NAS ...NR	DC	SL04	NNF	NNF	-	Full Comp Sheave Roller Sealed Snap Ring

Needle Roller Bearings

IKO	KOYO/TOR	INA	FAG	SKF	MCGILL	Description
NAST	STO...DZ	STO...X	STO...DZ	STO...X	-	RF - sep. w/Inner Ring, Crowned Outer Ring
NAST...R	STO	STO	STO	STO	-	RF - sep w/ Inner Ring, Sealed, Crowned Outer Ring
NATA	-	NKIA	NKJA	NKIA	-	Comb NR with Angular Contact
NATB	-	NKIB	NKJB	NKIB	-	Comb NR with 3-Point Contact
NAX	-	NKX	NAXK	NKX	-	-
NAX...Z	-	NKX...Z	NAXK...Z	NKX...Z	-	-
NBX	-	NKXR	NAXR	NKXR	-	-
NBX...Z	-	NKXR...Z	NAXR...Z	NKXR...Z	-	-
NTB	AXK	AXK	AXK	AXK	-	NR - Thrust
NUCF...R	-	NUKR	-	-	MCFD	CF- Cyl. Roller, Hex Crowned Outer Ring
NURT	-	NUTR...X	-	-	MCYRD...X	RF - Full comp, cyl. Roller, cyl outer ring
NURT...R	-	NUTR	-	-	MCYRD	RF - Full comp, cyl. Roller, crowned outer ring
RNA	RNA	RNA	RNA	RNA	-	NR w/o Inner Ring
RNAF	-	RNAO	RNAO	RNAO	-	-
TAF	NK	NK	NK	NK	-	NR - Machined w/o Inner Ring
TAFI	NKJ	NKI	NKJ	NKI	-	NR - Machined wit Inner Ring
TLA	HK	HK	HK	HK	-	NR - Shell type
TLAM	BK	BK	BK	BK	-	NR - Shell type, closed end
WS	WS	WS	WS	WS	-	NR - Thrust, inner ring, Shaft washer
YB	Y	SN	-	-	-	-
UU*	2RS	2RS / PP	2RS / 2LS	2RS	SS	Sealed